

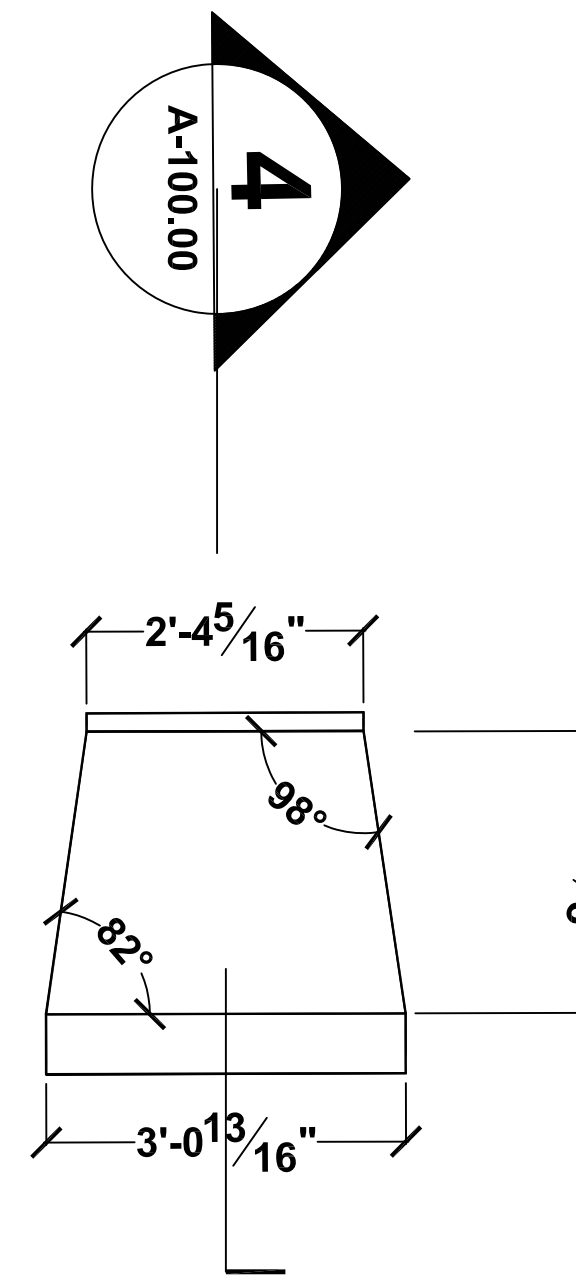

**5** PERSPECTIVE VIEW  
A-100.00 SCALE 1:1



**3** PERSPECTIVE VIEW  
A-100.00 SCALE 1:1



**1** PLAN VIEW  
A-100.00 SCALE 1:1

ZIG-ZAG CHAIR, 1941  
DESIGNER: GERRIT RIETVELD,  
ELM WITH STEEL SCREWS  
30 X 18 X 24 INCHES

THE REMARKABLY SIMPLE APPEARANCE OF THIS ZIG-ZAG CHAIR BELIES ITS COMPLEX DOVETAIL CONSTRUCTION, LEADING THE ARTIST GERRIT RIETVELD TO DESCRIBE IT AS HIS "DESIGNER'S JOKE." THE FOUR RECTANGULAR PLANES MEETS AT ANGLES, THUS REQUIRING DOVETAILED JOINTS AND REINFORCEMENT BY SCREWS AND WOODEN WEDGES. VISUALLY, HOWEVER, THE CHAIR IS COHESIVE AND ANTICIPATES THE SINGLE-PIECE MOLDED CONSTRUCTION OF 1960S PLASTIC CHAIR. AS A PROMINENT MEMBER OF THE DITCH DE STIJL (THE STYLE) MOVEMENT, RIETVELD ADHERED TO THE GROUPS ADVOCACY OF PURE ABSTRACTION BY REDUCTION TO THE ESSENTIALS OF FORM AND COLOR. WITH JUST BASE, SUPPORT, SEAT, AND BACK, RIETVELD'S DECONSTRUCTED CHAIR BARES NO RESEMBLANCE TO PREVIOUS FURNITURE FORMS.



**6** PERSPECTIVE VIEW  
A-100.00 SCALE 1:1

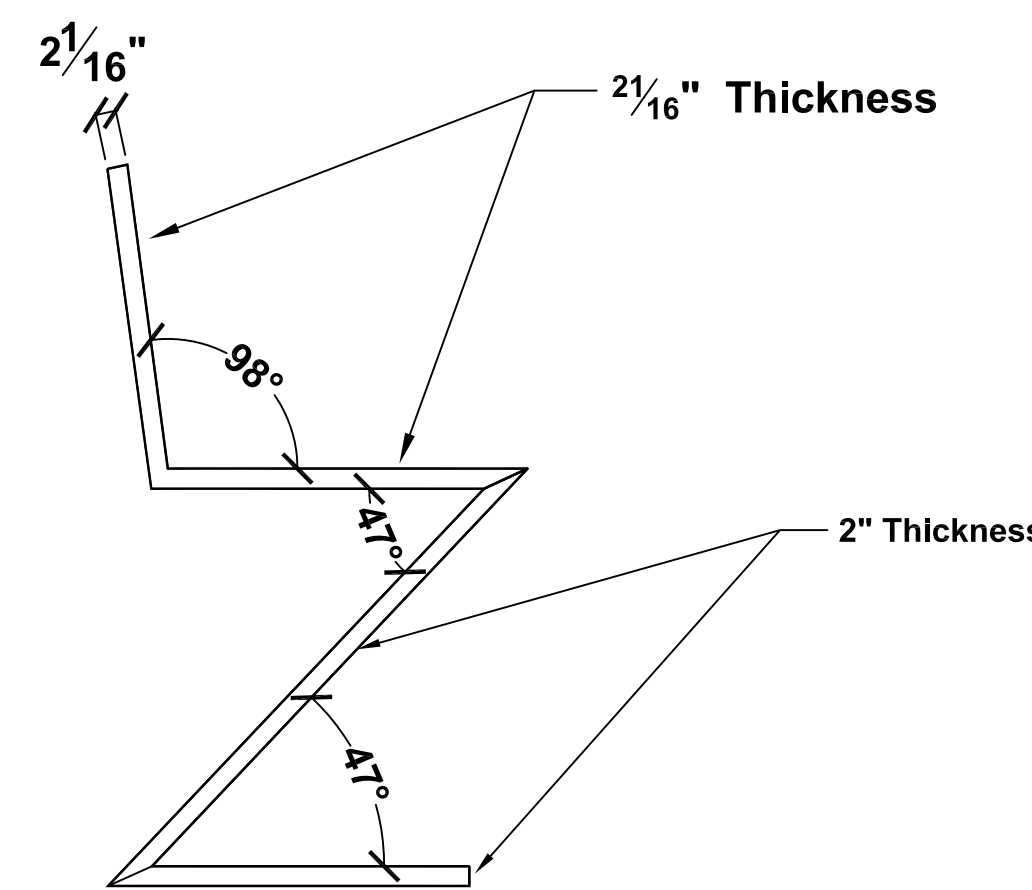

**4** SECTION VIEW  
A-100.00 SCALE 1:1

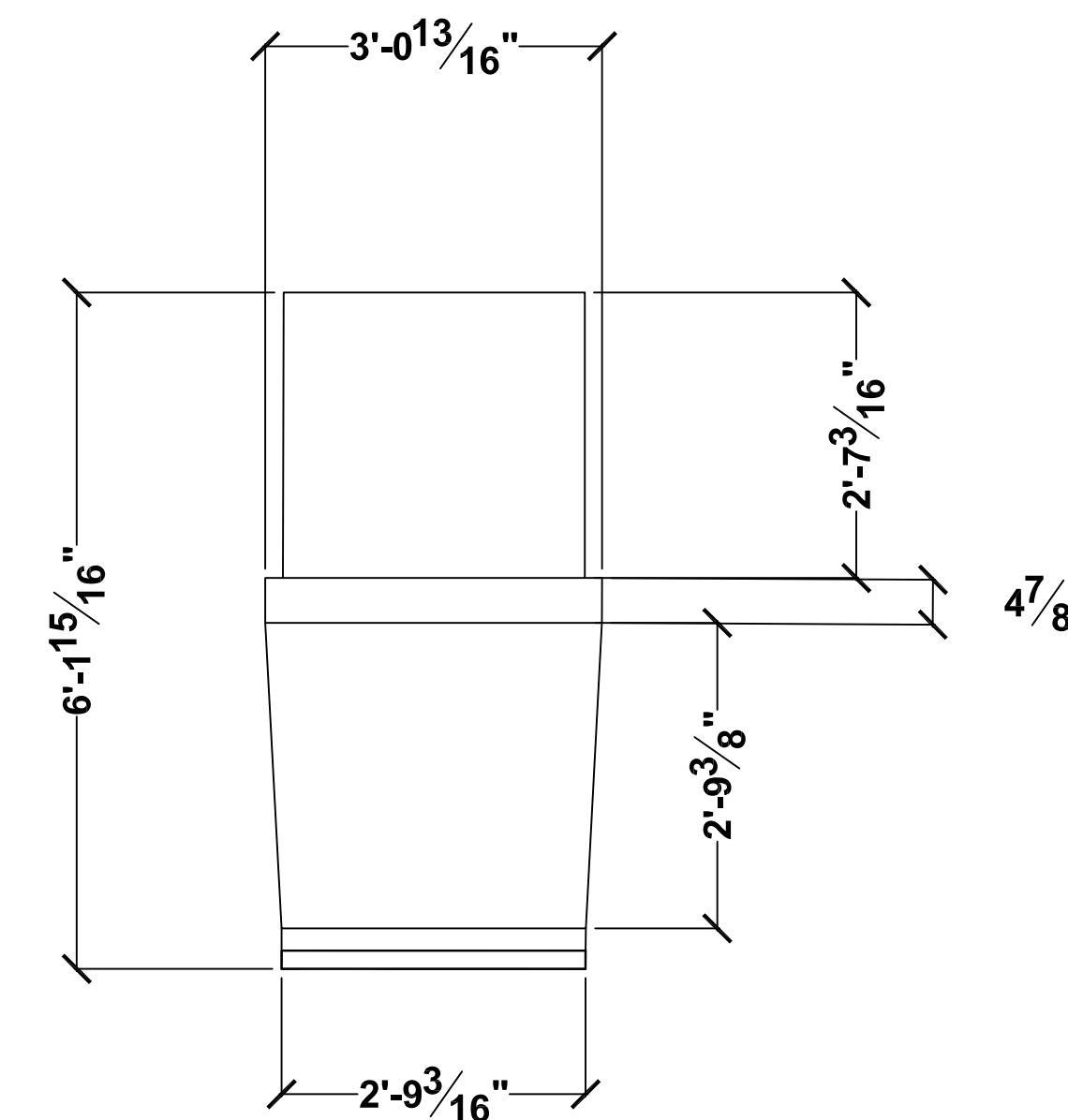

**2** ELEVATION VIEW  
A-100.00 SCALE 1:1

PROJECT:  
GERRIT RIETVELD'S ZIG-ZAG CHAIR  
PROF. T.WU

CITYTECH  
ARCH 1230  
DATE: 9.16.2015  
PROJECT  
DRAWING BY: LEE-ANN C.  
CHK BY: PROF. T.WU  
DWG NO: 100