



Enrique Browne

Architect Enrique Browne began his architect career in 1982. Sergio Larraine and Cristian Fernandez Cox and Enrique co-founded the taller America firm.

Enrique designed his buildings in a way that keep the nature and architecture united and not against one another. Another thing that sets Enrique from other architects is that he doesn't know that his project is finished until he gets a feeling that it is good.

The architects that could have had an influence on how he designed are;

Frank Gehry, Lucio Costa, Oscar Niemeyer, Norman foster, and Richard Rogers.

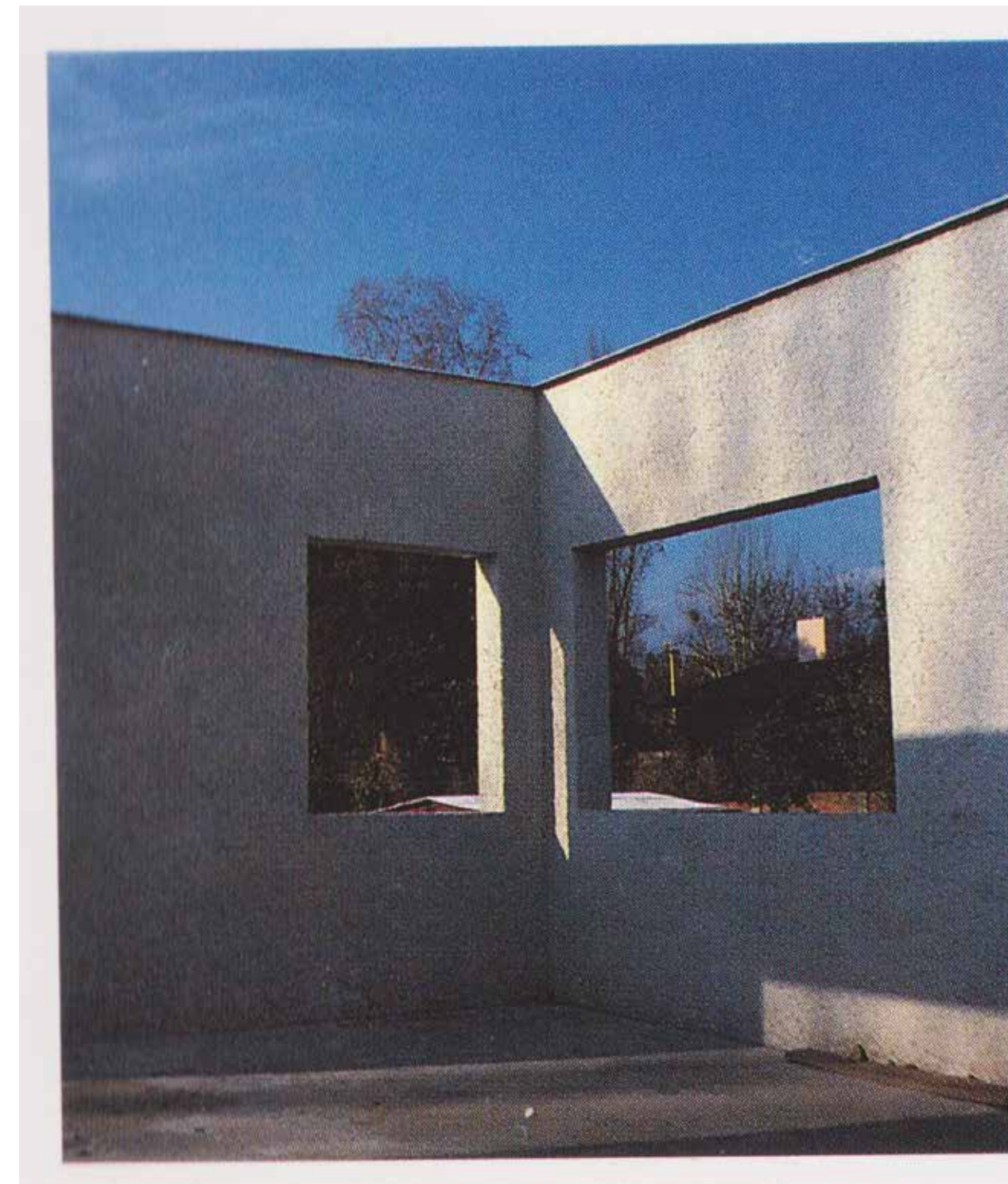
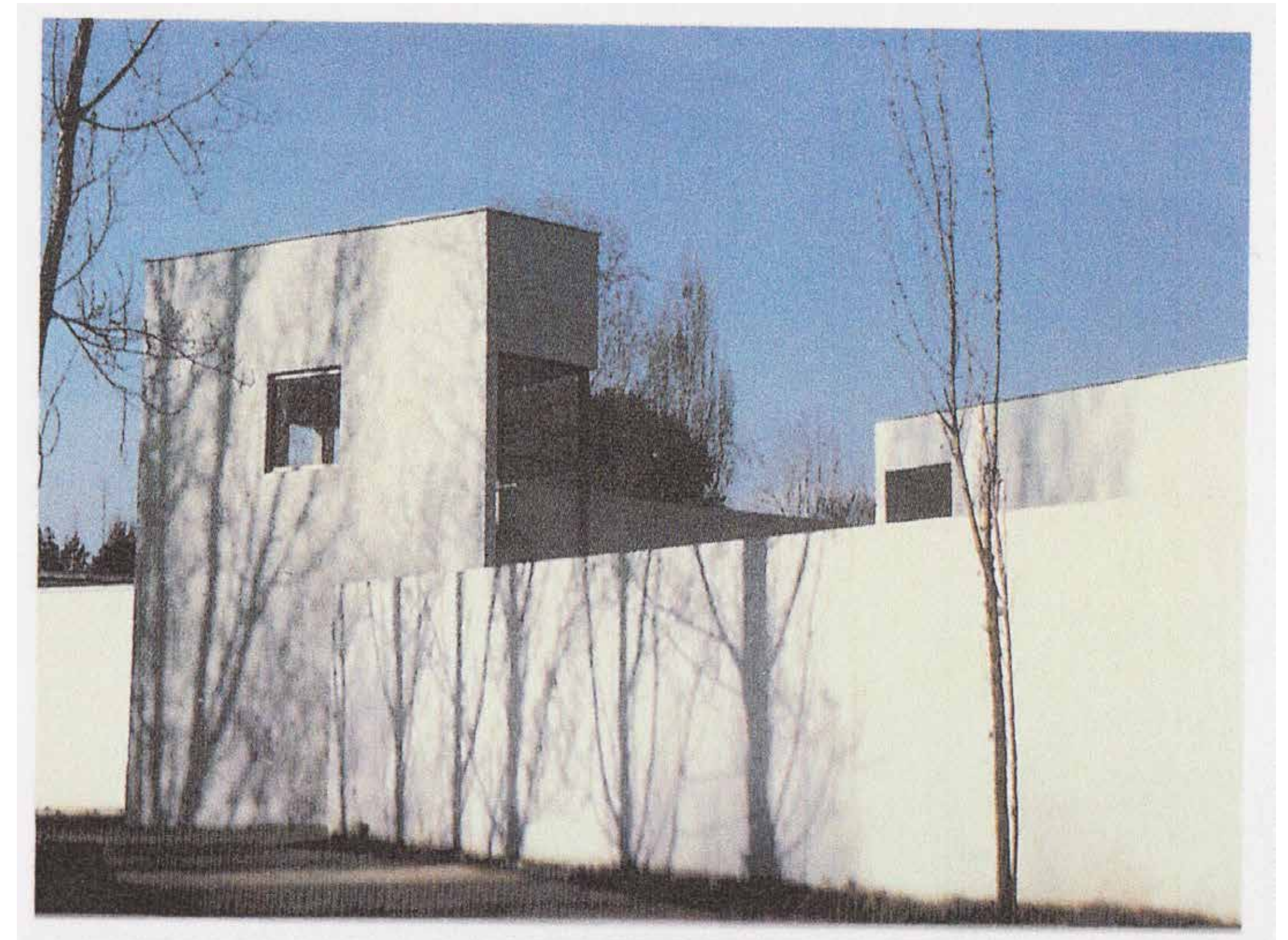

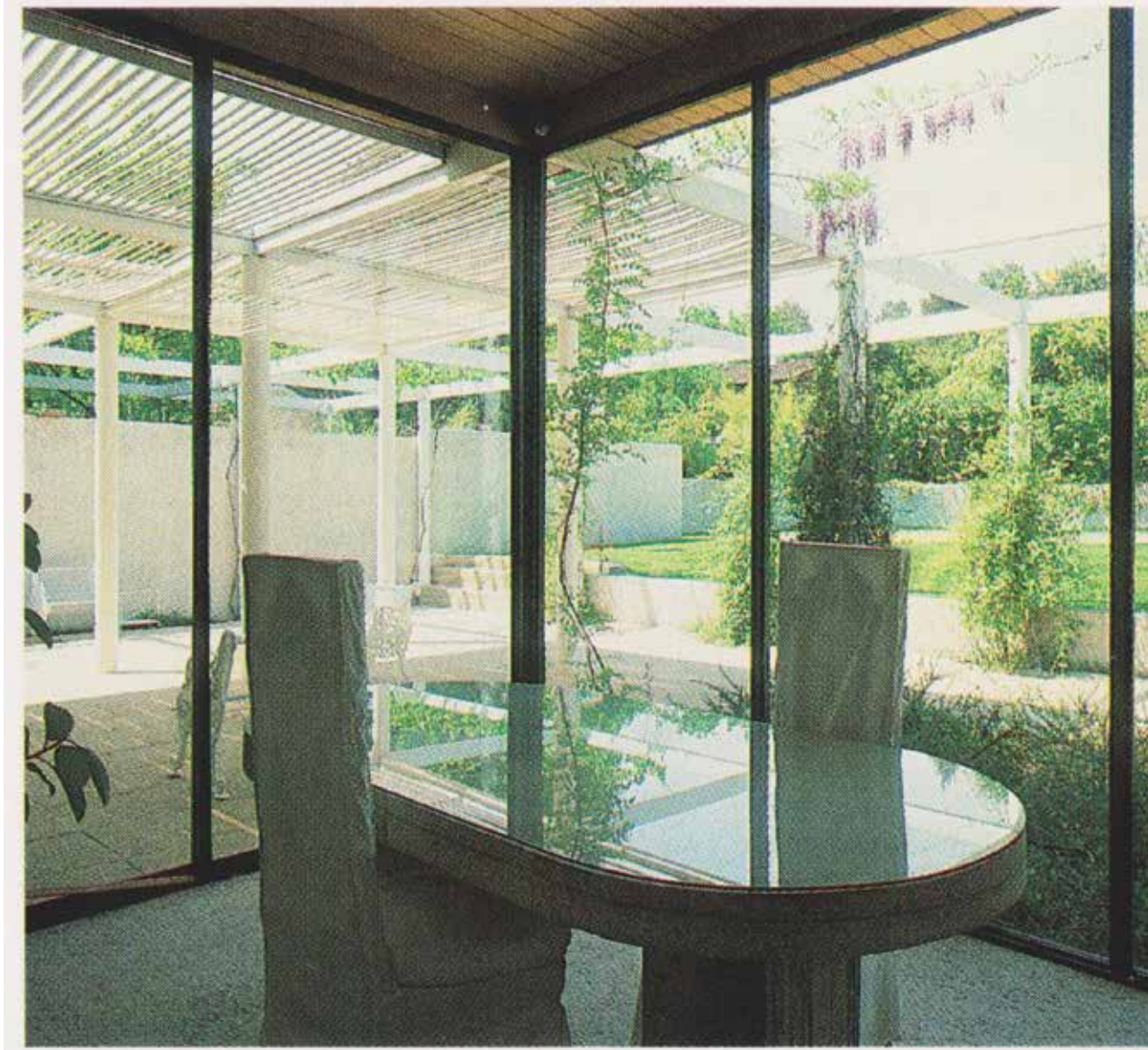

house on la fuente street:
Las Condes, Santiago, Chile

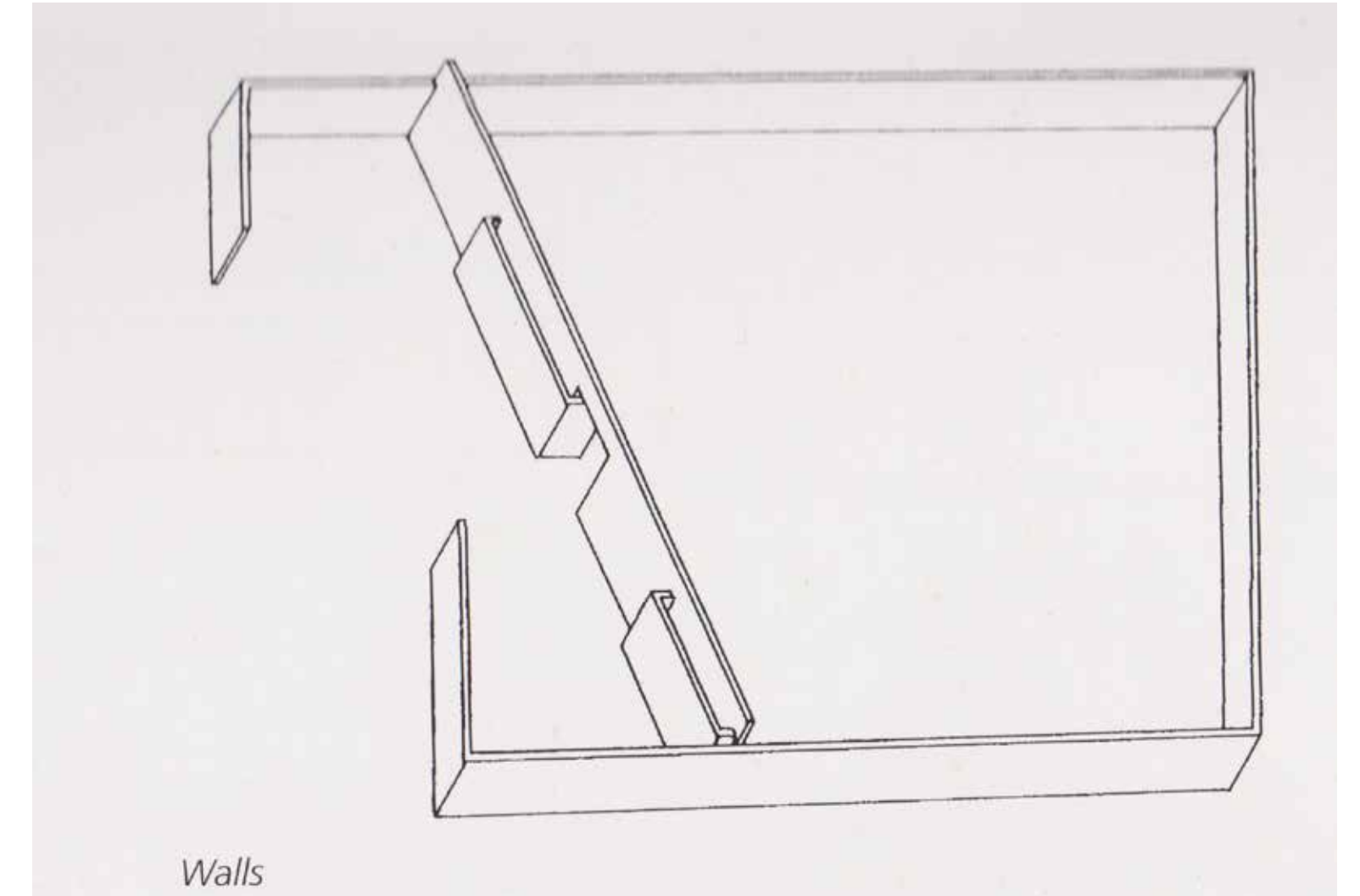

Walls

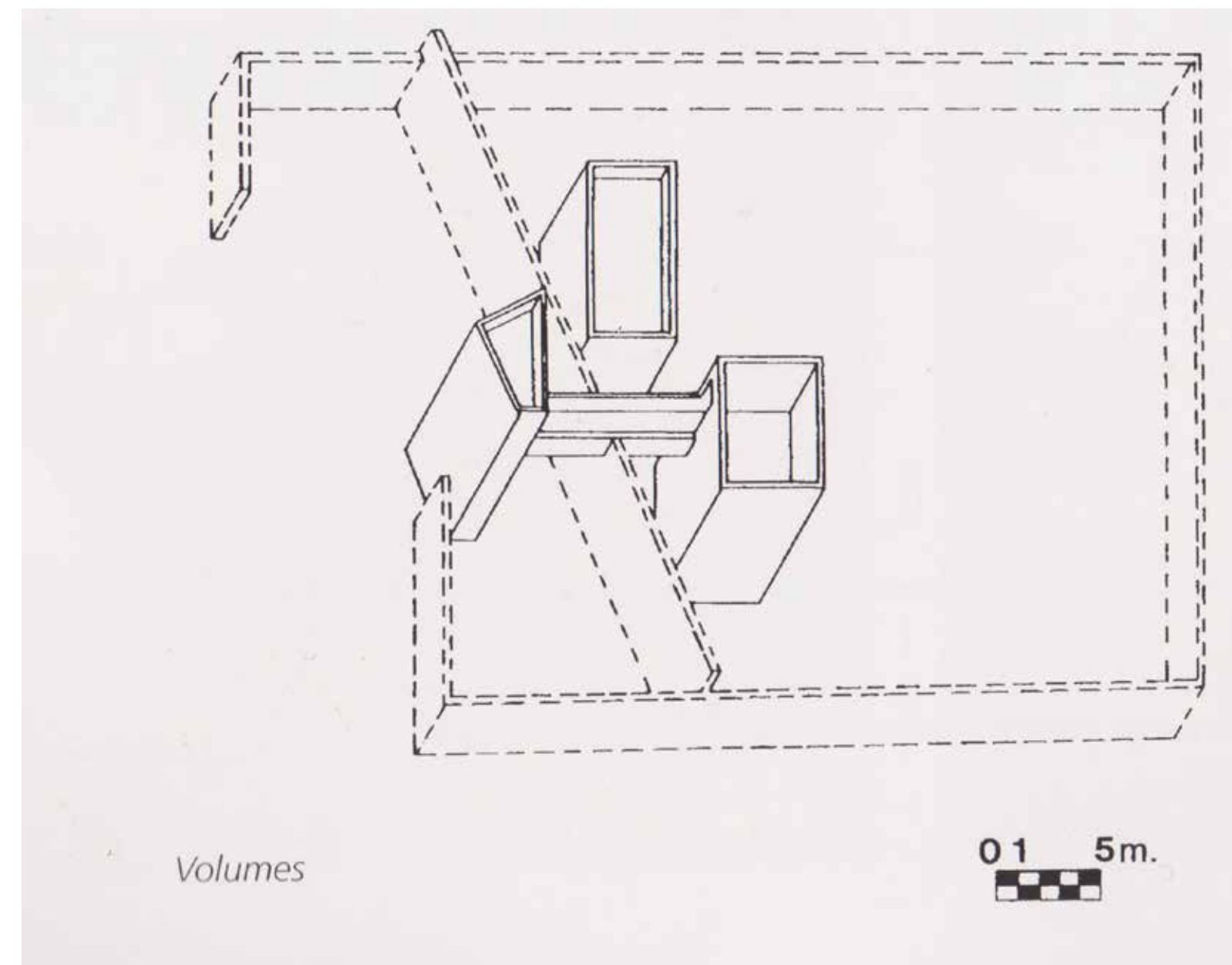
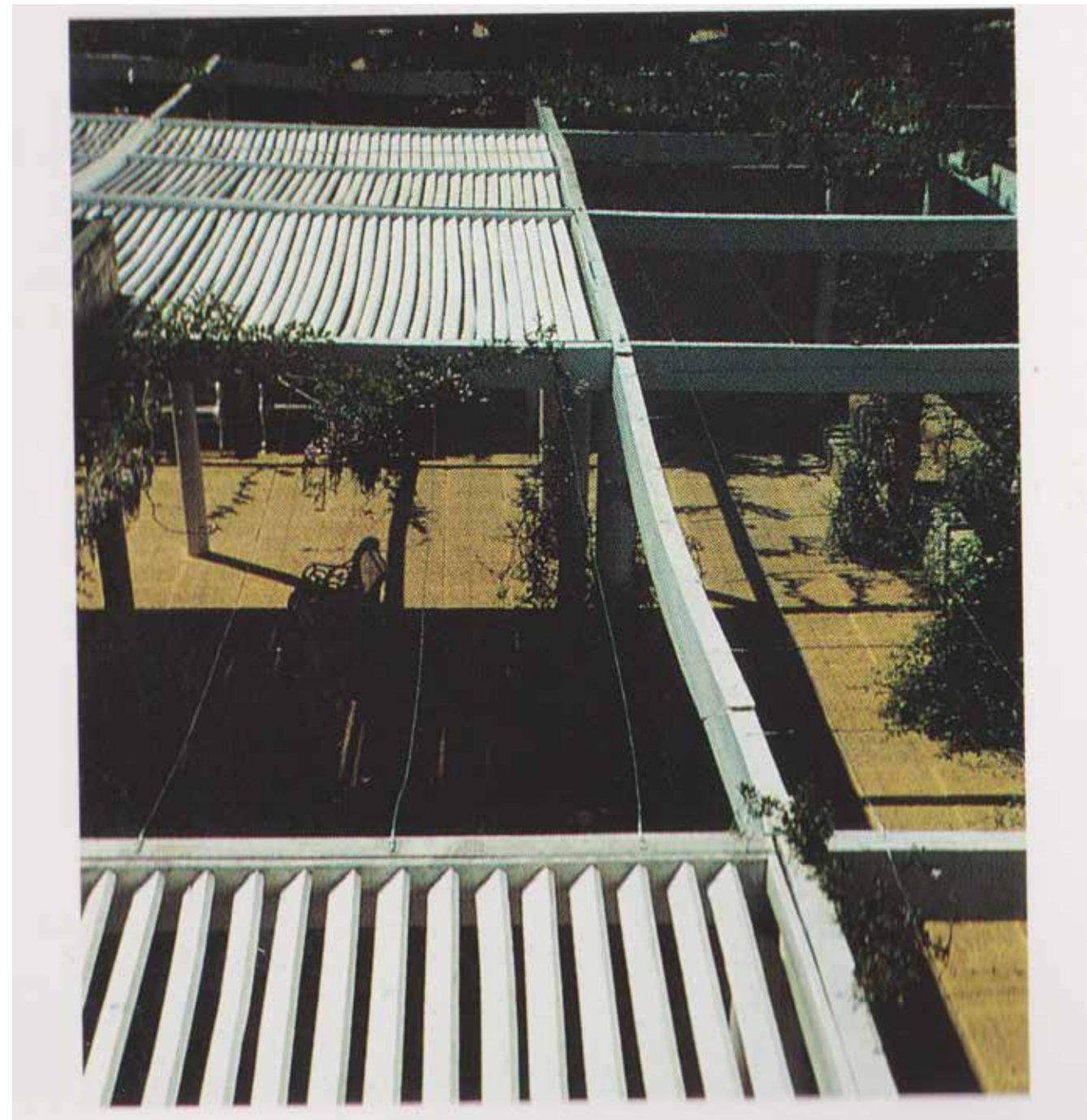

Volumes

01 5m.

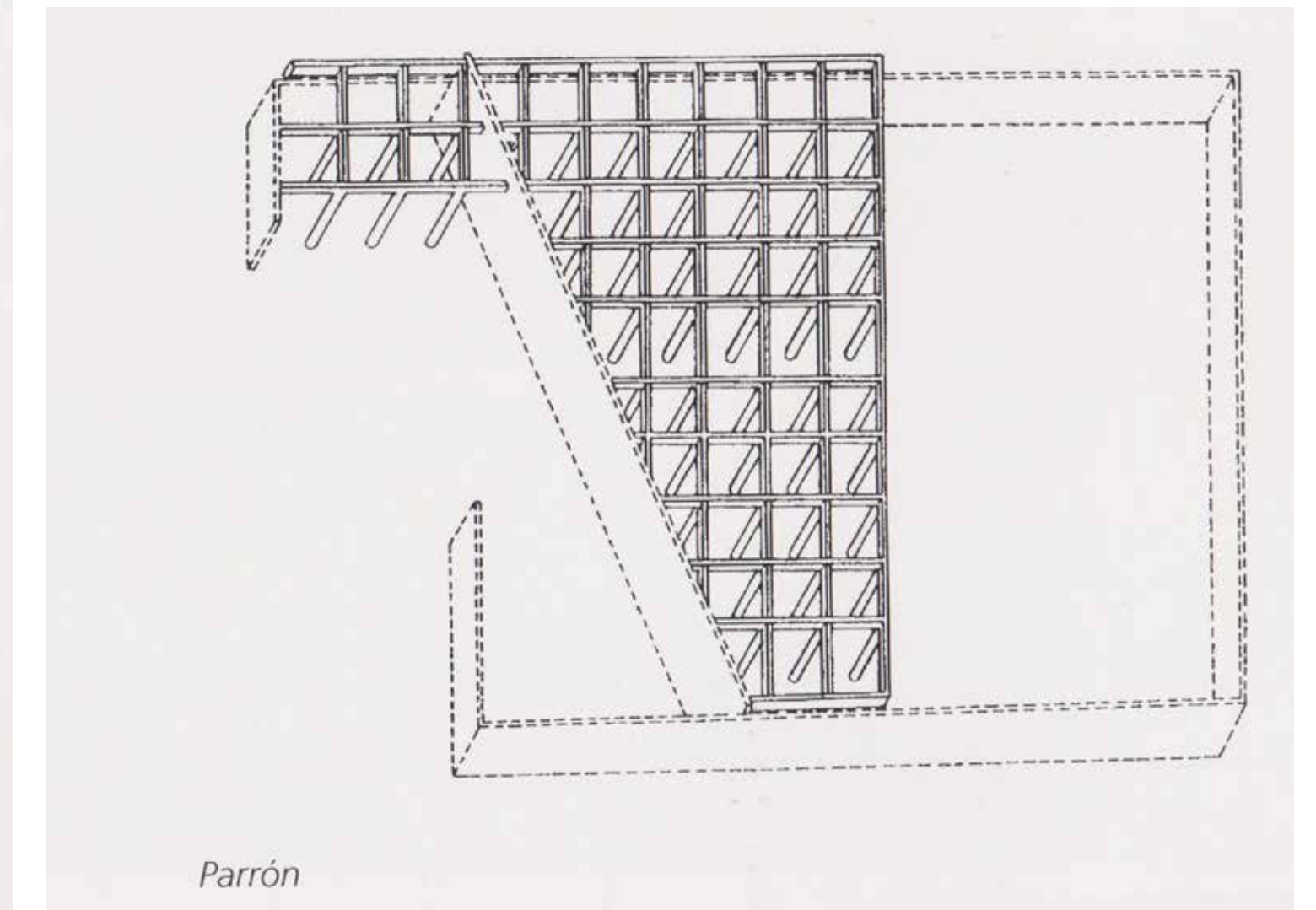

Parrón

GROUND FLOOR PLAN

1. Entrance Patio
2. Parking
3. Entrance
4. Hall
5. Living Room
6. Dining Room
7. Kitchen
8. Service Bedroom
9. Den
10. Library
11. Bedroom
12. Main Bedroom
13. Dressing Room
14. Patio
15. Garden Patio
16. Pool
17. Storage-Changing Rooms

SECOND FLOOR PLAN

18. Office
19. Terrace Patio

