

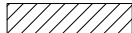









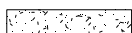
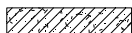
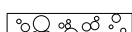

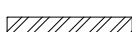

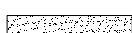
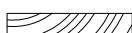
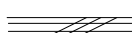
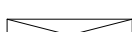
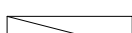
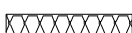





































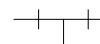

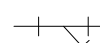
MATERIAL SYMBOLS

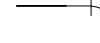
	STONE CLADDING
	CONCRETE BLOCK
	CONCRETE
	ARCHITECTURAL PRECAST CONCRETE
	POROUS FILL
	EARTH
	METAL
	GYPSUM WALLBOARD
	GWB SOFFIT OR CEILING
	WOOD
	PLYWOOD
	WOOD ROUGH FRAMING
	SHIM
	BATT INSULATION
	RIGID INSULATION
	FIRE SAFING
	IMPREGNATED FOAM SEALANT
	SEALANT AND BACKER ROD

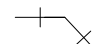
ELECTRICAL SYSTEMS

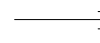
CEILING FIXTURE	
CEILING FIXTURE WITH FULL SWITCH	
WALL MOUNTED FIXTURE	
RECESSED CEILING FIXTURE-OUTLINE SHOWS SHAPE	
FLUORESCENT FIXTURE	
FLUORESCENT FIXTURE CONVENIENCE DUPLEX OUTLET	
SPLIT WIRED DUPLEX OUTLET	
WEATHER PROOF OUTLET	
OUTLET WITH GROUND FAULT INTERRUPTER	
SPECIAL-EQUIPMENT OUTLET	
RANGE OUTLET	
PUSH BUTTON	
CHIME	
TRANSFORMER	
TELEPHONE	
INTERCOM	
TELEVISION ANTENNA	
SMOKE DETECTOR	
FLUORESCENT FIXTURE	
FLUORESCENT FIXTURE	
SINGLE-POLE SWITCH	S
THREE-WAY SWITCH	S ₃
SWITCH WITH PILOT LIGHT	S _p
WEATHERPROOF SWITCH	S _w

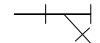
PLUMBING SYMBOLS

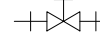
PIPING	
DRAIN OR WASTE ABOVE GROUND	
DRAIN OR WASTE BELOW GROUND	
VENT	
COLD WATER	
HOT WATER	
HOT WATER HEAT SUPPLY	
GAS	
PIPE TURNING DOWN OR AWAY	
PIPE TURNING UP OR TOWARD	
BREAK-PIPE CONTINUES	
FITTINGS	
TEE	 
WYE	 
ELBOW-90°	 
ELBOW-45°	 
CAP	 
UNION CLEANOUT	 
STOP VALVE	 

DRAWING LIST

C-101	COVERSHEET WITH PERSPECTIVE OR 3D IMAGES
G-102	DRAWING LIST
G-103	ABBREVIATIONS, DRAWING LISTS, SYMBOLS, ETC
G-104	ADA DRAWINGS AND TEXT
Z-101	SITE PLAN/ZONING ANALYSIS ZONING TEXT
Z-102	SITE PLAN/ZONING ANALYSIS ZONING TEXT
SK-101	STAIR STUDIES
FLOOR PLANS	
A-100	BASEMENT LEVEL-COMPOSITE
A-100.A	BASEMENT-ATRIUM
A-100.G	BASEMENT-GYM
A-100.L	BASEMENT-LABZ
A-101	1ST FLOOR-COMPOSITE
A-101.A	1ST FLOOR-ATRIUM
A-101.G	1ST FLOOR-GYM
A-101.L	1ST FLOOR-LAB
A-102	2ND FLOOR/MEZZANINE-COMPOSITE
A-103	TYPICAL LAB FLOOR-TYPE A & DOOR
A-104	TYPICAL LAB FLOOR-TYPE B & DOOR
A-105	ROOF PLAN-COMPOSITE
A-105.A	ROOF PLAN-ATRIUM
A-105.G	ROOF PLAN-GYM
A-105.L	ROOF PLAN-LAB
RCP PLANS	
A-201	1ST FLOOR-COMPOSITE
A-201.A	1ST FLOOR-ATRIUM
A-201.G	1ST FLOOR-GYM
A-201.L	1ST FLOOR-LAB
A-202	2ND FLOOR/MEZZANINE-COMPOSITE
A-203	TYPICAL LAB FLOOR-TYPE A
A-204	TYPICAL LAB FLOOR-TYPE B
BUILDING SECTIONS AND EXTERIOR ELEVATIONS	
A-300	BUILDING SECTIONS
A-301	BUILDING SECTIONS
A-302	EXTERIOR ELEVATIONS-NORTH & SOUTH
A-303	EXTERIOR ELEVATIONS-EAST & WEST
A-304	EXTERIOR ELEVATIONS-NORTH
A-305	EXTERIOR ELEVATIONS-SOUTH
A-306	EXTERIOR ELEVATIONS-EAST
A-307	EXTERIOR ELEVATIONS-WEST
PLAN DETAILS	
A-400	PARTITION TYPES
A-401.1 401.2	PLAN DETAILS-GYM
A-402.1 402.2	PLAN DETAILS-ATRIUM
A-403.1 403.2	PLAN DETAILS-TYPICAL LAB
WALL SECTIONS & DETAILS	
A-500	WALL SECTIONS-GYM
A-501.1 501.2	WALL SECTION DETAILS-GYM
A-502	WALL SECTIONS-ATRIUM
A-503.1 503.2	WALL SECTIONS DETAILS-ATRIUM
A-504	WALL SECTIONS-LAB
A-505.1 505.2	WALL SECTION DETAILS-LAB
PARTIAL PLANS & INTERIOR ELEVATIONS	
A-600	CORE PLANS
A-601	CORE PLANS
A-602	STAIR PLANS & SECTIONS (MIN 1 STAIR)
A-604	STAIR DETAILS
A-605	PARTIAL PLANS & ELEVATIONS- BATHROOMS
STRUCTURAL	
S-100	FOUNDATION PLAN-COMPOSITE
S-102	2ND FLOOR/MEZZANINE-COMPOSITE



G103- Drawing symbols

BUILDING INFORMATION

285 JAY ST
BROOKLYN, NY 11201

ZONING: C6-4
BLOCK: 131
LOT: 1
LOT AREA: 139 810 SQ FT
FAR: 10

USE GROUP:
PUBLIC FACILITY/ INSTITUTION

NUMBER OF BUILDINGS ON LOT:
2

DATE 02/14/14
DRAWN BY D. SECLIN
PROFESSOR P. KING

G-103

604. WATER CLOSETS AND TOILET COMPARTMENTS

604.1 GENERAL. Water closets and toilet compartments shall comply with 604.2 through 604.8

EXCEPTION: Water closets and toilet compartments for children's use shall be permitted to comply with 604.9.

604.2 LOCATION. The water closet shall be positioned with a wall or partition to the rear and to one side. The centerline of the water closet shall be 16 inches (405 mm) minimum to 18 inches (455 mm) maximum from the side wall or partition, except that the water closet shall be 17 inches (430 mm) minimum and 19 inches (485 mm) maximum from the side wall or partition in the ambulatory accessible toilet compartment specified in 604.8.2 Water closets shall be arranged for a left-hand or right-hand approach.

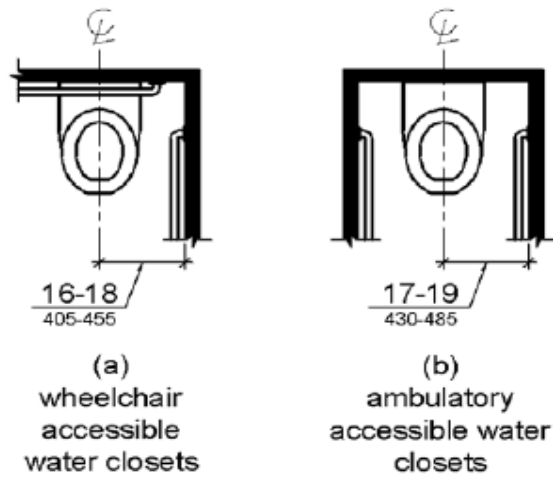

604.3.1 SIZE. Clearance around water closet shall be 60 inches minimum measured perpendicular from the side wall and 56 inches minimum measured perpendicular from the rear wall.

604.4. SEATS. The seat height of a water closet above the finish floor shall be 7 inches (430 mm) minimum and 19 inches (485 mm) maximum measured to the top of the seat. Seats shall not be sprung to return to a lifted position. There is an exception.

604.5.1 SIDE WALL. The side wall grab bar shall be 42 inches long minimum, located 12 inches maximum from the rear wall and extending 54 inches minimum from the rear wall.

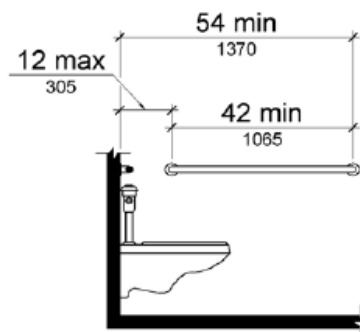

305. CLEAR FLOOR OR GROUND SPACE

305. GENERAL. Clear floor or ground space shall comply with 305.

305.2 FLOOR OR GROUND SURFACES. Floor or ground surfaces of a clear floor or ground space shall comply with 302. Changes in level are not permitted. Exception: Slopes not steeper than 1:48 shall be permitted.

305.3 SIZE. The clear floor or ground space shall be 30 inches minimum by 48 inches minimum.

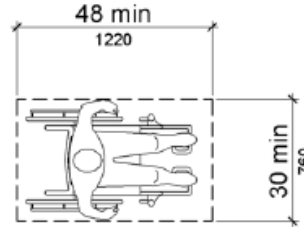

305.5 POSITION. Unless otherwise specified, clear floor or ground space shall be positioned for either forward or parallel approach to an element.

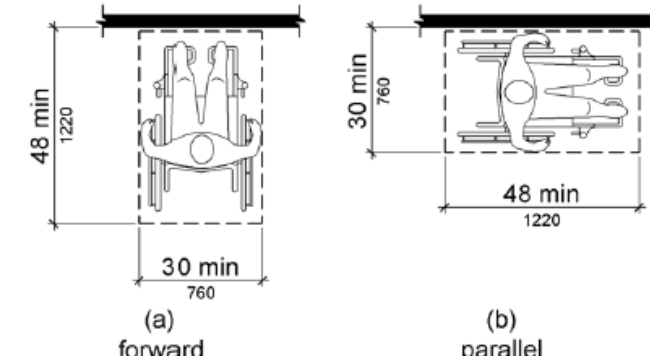

404. DOORS, DOORWAYS AND GATES.

404.2.4.1 MANEUVERING. Maneuvering clearances at manual swinging doors and gates.

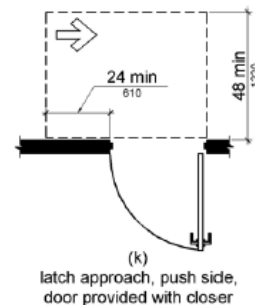
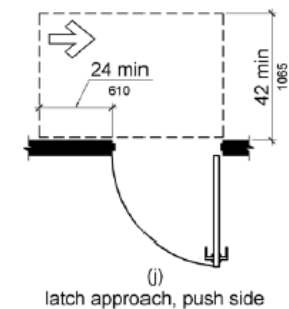
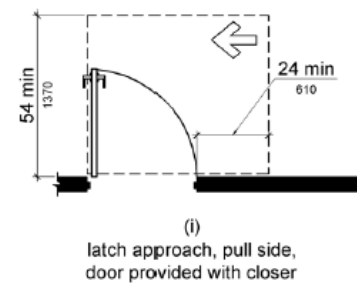
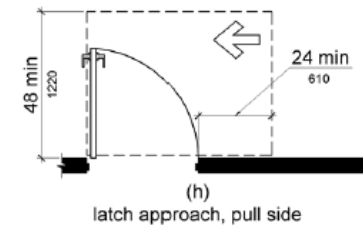
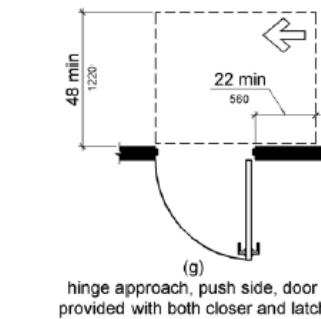

404.2.4.2 Maneuvering clearances at doorways without doors, sliding doors, gates and folding doors.

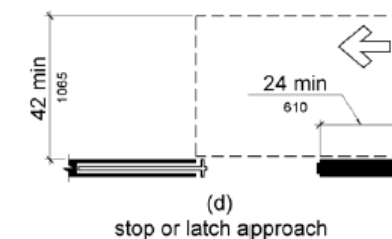
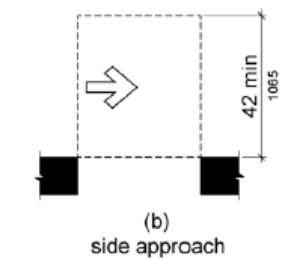
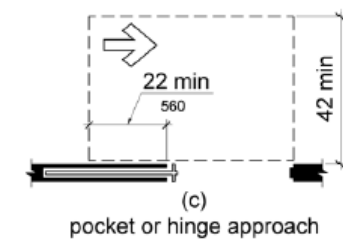
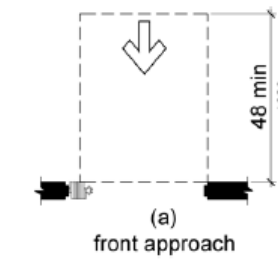

G-104 ADA Standards

BUILDING INFORMATION

285 JAY ST
BROOKLYN, NY 11201

ZONING: C6-4
BLOCK: 131
LOT: 1
LOT AREA: 139 810 SQ FT
FAR: 10

USE GROUP:
PUBLIC FACILITY/ INSTITUTION

NUMBER OF BUILDINGS ON LOT:
2

DATE: 02/07/14
DRAWN BY: D. SECLIN
PROFESSOR: P. KING

G-104