

ADA Standard Information & Federal and National Codes:
 ADA – Americans with Disabilities Act (1990)

- This is not a code it is a law. NYC Local Law 58/87 enforces accessibility.
- Requires that buildings be made accessible to persons with physical and mental disabilities
- US department of Justice enforces the law through legal actions. Regulations & Guidelines in the US Department of Justice Webpage
- ADA is applied to new constructions
- If you are renovating an existing structure, the area being renovated must comply with the ADA law.

Alternate Means and Methods of construction allowed by code. Section 104.11 (states that requirements must be reviewed by building officials)

- Technology Advances
- Design (atriums, malls, etc.)
- Must be equivalent to the requirements prescribed by the code:
- Quality - Fire Resistance
- Strength
- Durability
- Effectiveness – Safety

All new work must comply with code for new construction

No Fire Escape in new Construction is permitted stairs (Min. of 22" wide, 8" riser and 8" tread allowed).

If stairs and escalators are provided – accessible route is to be provided
 If ramps are necessary they are to be designed as follows:

- >1:10, <1:8, max 3" rise for 24" length - > 1:12, <1:10

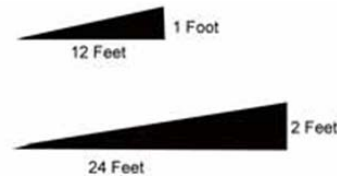

604 Water Closets and Toilet Compartments

604.1 General. Water closets and toilet compartments shall comply with 604.2 through 604.8.

EXCEPTION: Water closets and toilet compartments for children's use shall be permitted to comply with 604.9.

604.2 Location. The water closet shall be positioned with a wall or partition to the rear and to one side. The centerline of the water closet shall be 16 inches (405 mm) minimum to 18 inches (455 mm) maximum from the side wall or partition, except that the water closet shall be 17 inches (430 mm) minimum and 19 inches (485 mm) maximum from the side wall or partition in the ambulatory accessible toilet compartment specified in 604.8.2. Water closets shall be arranged for a left-hand or right-hand approach.

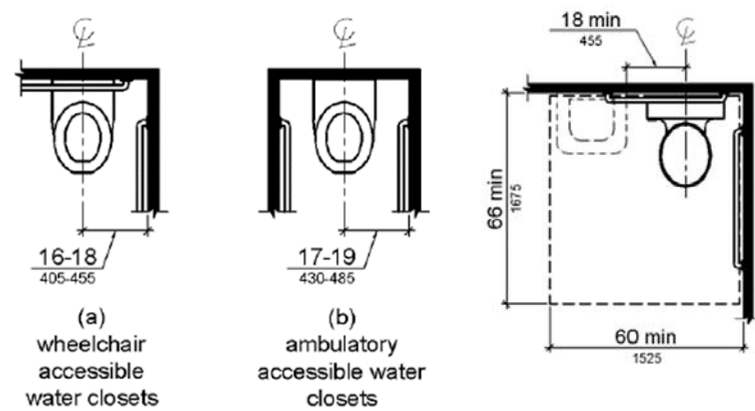

604.3.1 Size. Clearance around a water closet shall be 60 inches (1525 mm) minimum measured perpendicular from the side wall and 56 inches (1420 mm) minimum measured perpendicular from the rear wall.

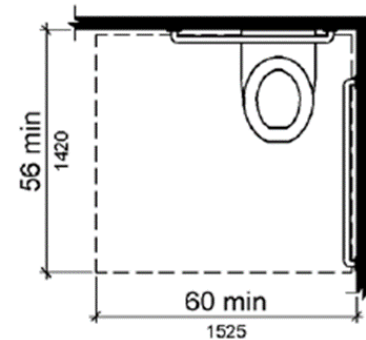

604.5.1 Side Wall. The side wall grab bar shall be 42 inches (1065 mm) long minimum, located 12 inches (305 mm) maximum from the rear wall and extending 54 inches (1370 mm) minimum from the rear wall.

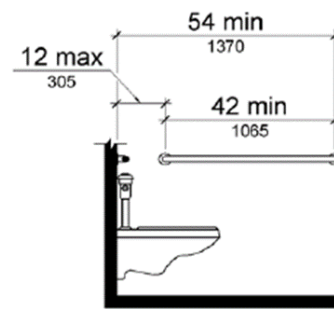

Advisory 604.8.1.1 Size. The minimum space required in toilet compartments is provided so that a person using a wheelchair can maneuver into position at the water closet. This space cannot be obstructed by baby changing tables or other fixtures or conveniences, except as specified at 604.3.2 (Overlap). If toilet compartments are to be used to house fixtures other than those associated with the water closet, they must be designed to exceed the minimum space requirements. Convenience fixtures such as baby changing tables must also be accessible to people with disabilities as well as to other users. Toilet compartments that are designed to meet, and not exceed, the minimum space requirements may not provide adequate space for maneuvering into position at a baby changing table.

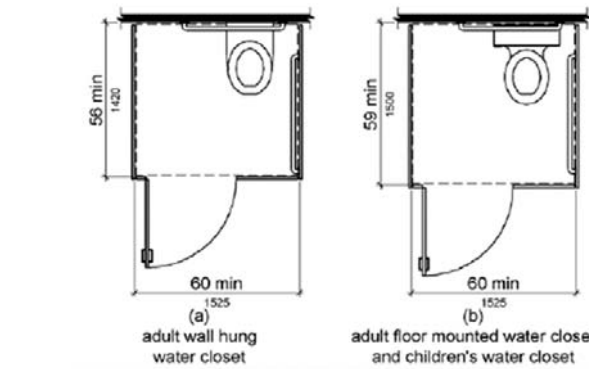

All Landing areas shall comply with a width of 36: in order for any person with a disability to rotate in a wheelchair 60" must be available in any landing due to ADA restrictions. For example elevators, ramps, doors, bathroom door swings, and entrances/exits.

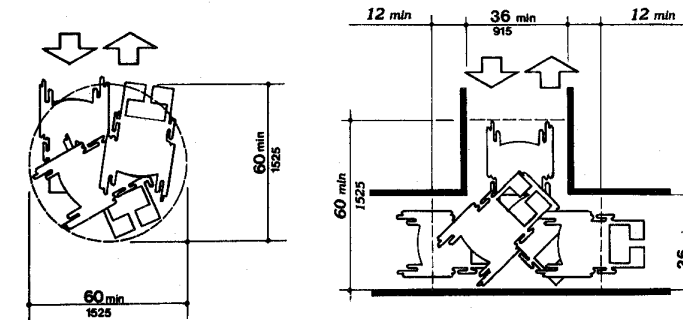

ADA Standards Effective 2010

Ramp Guidelines
 Ramp Landings/ Wheelchair rotations
 Accessible Bathroom
 Minimum Door Swings

Location Information

House No(s)	
Street Name	285 Jay St
Borough	Brooklyn
Block	131
Lot	1
BIN	

Falsification of any statement is a misdemeanor and is punishable by a fine or imprisonment, or both. It is unlawful to give to a city employee, or for a city employee to accept, any benefit, monetary or otherwise, either as a gratuity for properly performing the job or in exchange for special consideration. Violation is punishable by imprisonment or fine or both. I understand that if I am found after hearing to have knowingly or negligently falsified or allowed to be falsified any certificate, form, signed statement, application, report or certification of the correction of a violation required under the provisions of this code or of a rule of any agency, I may be barred from filing further applications or documents with the Department.

Name (please print)
 Eric Ortiz

Signature
 Eric Ortiz

Date

P.E. / R.A. Seal (apply seal, then sign and date over seal)

Internal Use Only

BIS Doc #

PLAN EXAMINER SIGN AND DATE