



AUTODESK® REVIT®
DESIGN • CONNECT • OPTIMIZE



ARCH 2431 Building Technology III Steel Assembly & Building Information Modeling (BIM) with Revit

Steel Connections Series

- #1 Introduction to Columns & Beams
- #2 Column Base Plates
- #3 Photos & Videos – Connections & Fasteners
- **#4 Concrete footing to baseplate connection**
- #5 Fin & Splice Plates – Notched Beams
- #6 Diagonal Bracing

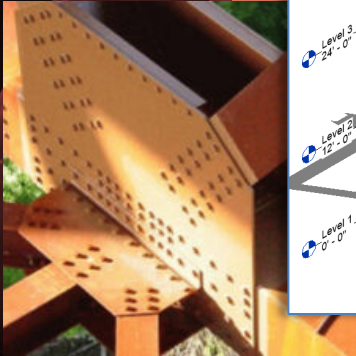
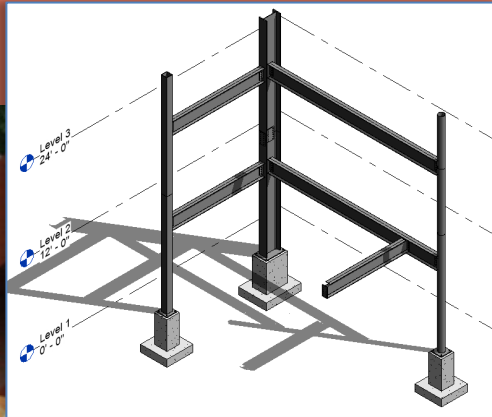

1.11

Building
Technology III

CityTech.CUNY.edu

Prof. Paul C. King, Course Coordinator
Prof. Blake Kurasek
Prof. Justin Sherman
Prof. Jieun Yang

Pking@CityTech.Cuny.Edu
Bkurasek@CityTech.Cuny.Edu
Jsherman@CityTech.Cuny.Edu
Jyang@CityTech.Cuny.Edu

Steel Connections Detail Development

- 22 X 34 Sheet
- Coordinated Views & Isometrics

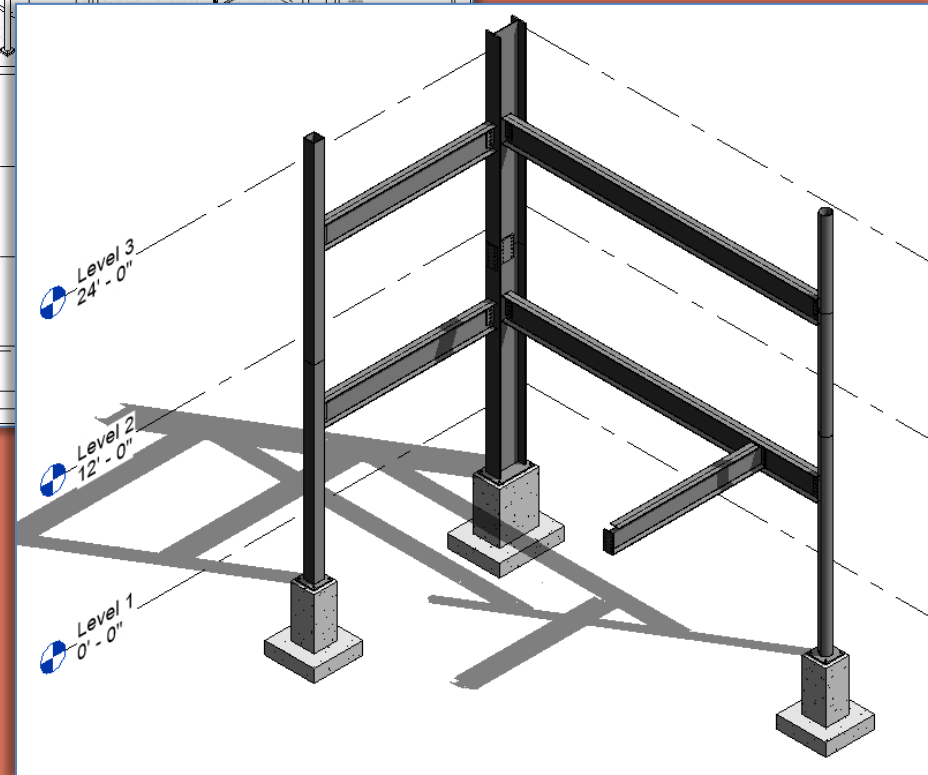
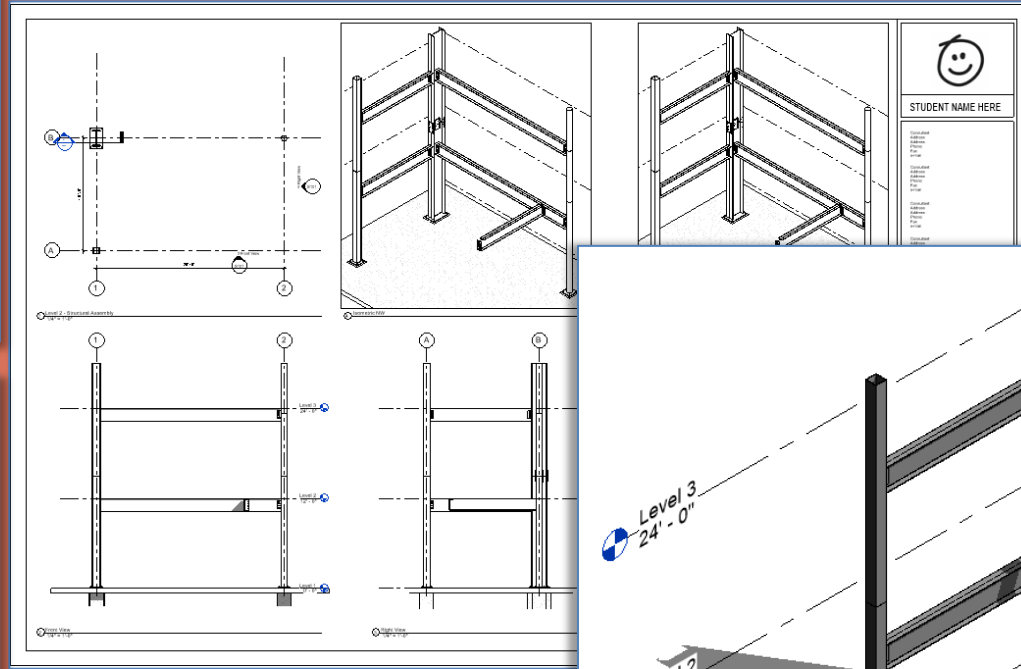

- *Base Plate & Footing*
- *Fin Plate Connection*
- *Splice Plate Connection*
- *Notched Beam with Bolting Plate*

Concrete Footing to Baseplate Connection

- **Connections**
 - Video & sample
- **Isolated Footing**
 - Concrete Extrusions
 - Cone Shaped Void
- **Components**
 - Threaded Rod
 - Nut & Washer
- **Concrete Footing Family**
 - Add Threaded Rod
 - Add Nut
 - Add Washers
 - Position & Copy
- **Steel Connections**
- **Project File**
 - Align & Lock Footings to the Columns
- **Concrete Footing Family**
 - Add Threaded Rod
 - Add Level 1 Floor Slab
 - Create Section Views &
- **Develop Details**
 - Create Section Views
 - Provide a good name
 - Add Notes & Leaders
 - Add Dimensions
 - Add to your sheet

https://www.youtube.com/watch?v=F4Lo5Z_eH9U

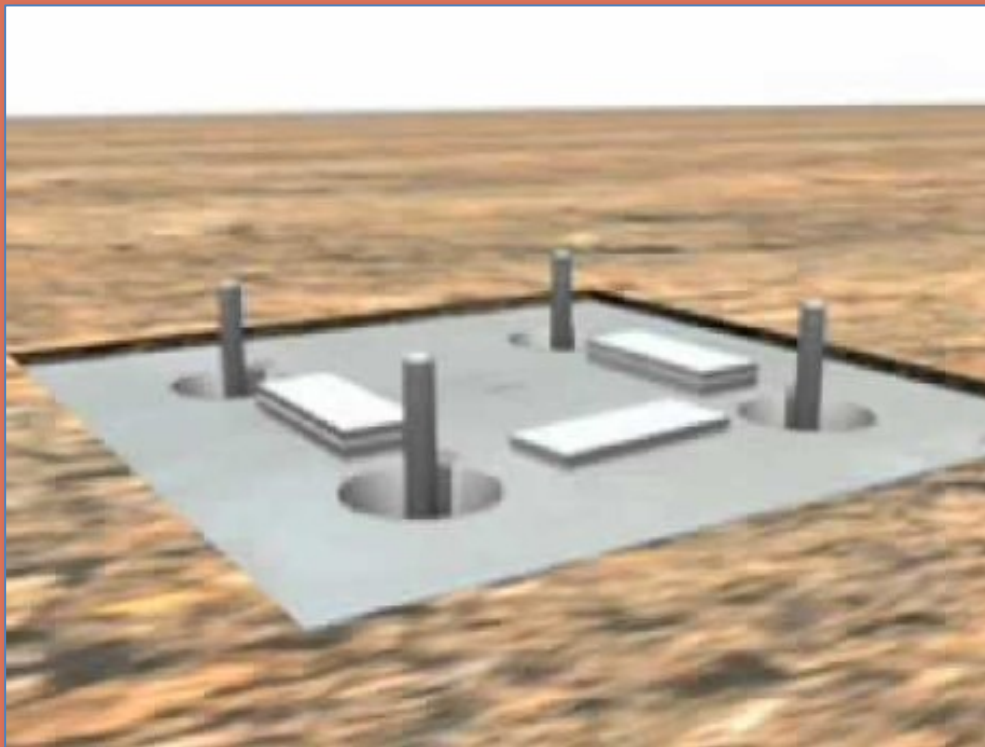

➤ *Watch the Video*

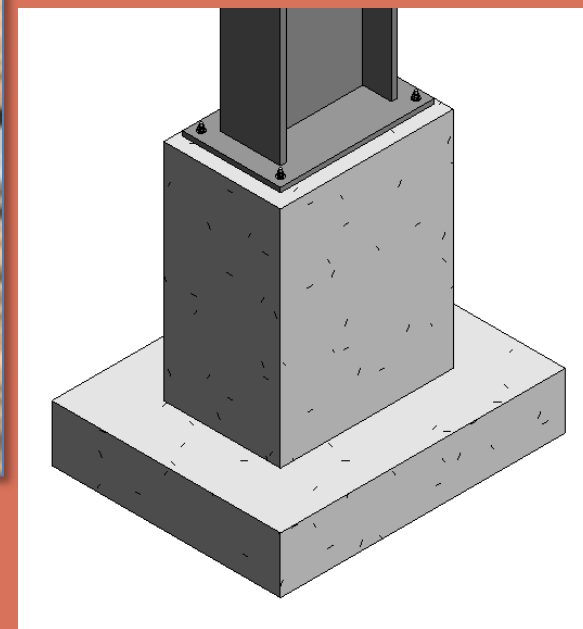

➤ *Column Base Plate to Isolate Footing*

- **Connections**
 - Video & sample
- **Isolated Footing**

- **Concrete Extrusions**
 - Cone Shaped Void
- **Components**
 - Threaded Rod
 - Nut & Washer

- **Concrete Footing Family**
 - Add Threaded Rod
 - Add Nut
 - Add Washers
 - Position & Copy

- **Steel Connections**
- **Project File**
 - Align & Lock Footings to the Columns

- **Concrete Footing Family**
 - Add Level 1 Floor Slab

- **Develop Details**
 - Create Section Views
 - Provide a good name
 - Add Notes & Leaders
 - Add Dimensions
 - Add to your sheet

Create Concrete Isolated Footing

- Create 8 reference Planes, Add Dimensions & Parameters
- Create > Extrusion (center of footing -4'-0" depth)
- Create > Extrusion (base of footing Start -4', End -5')

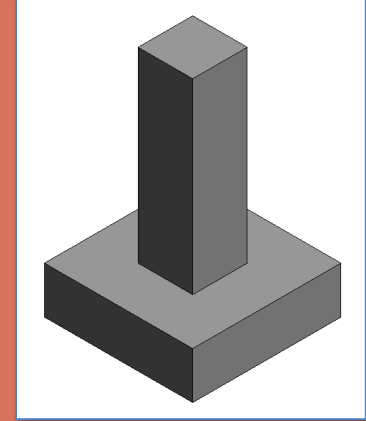
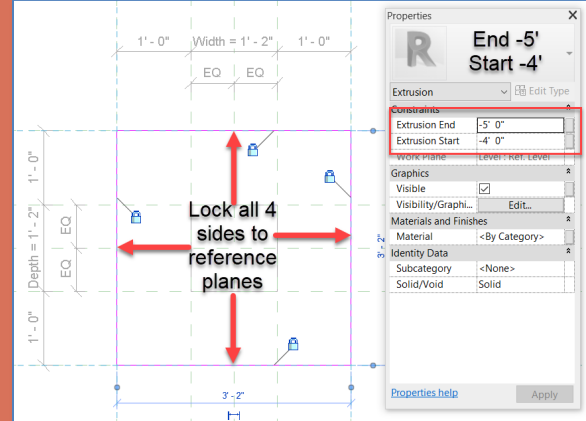
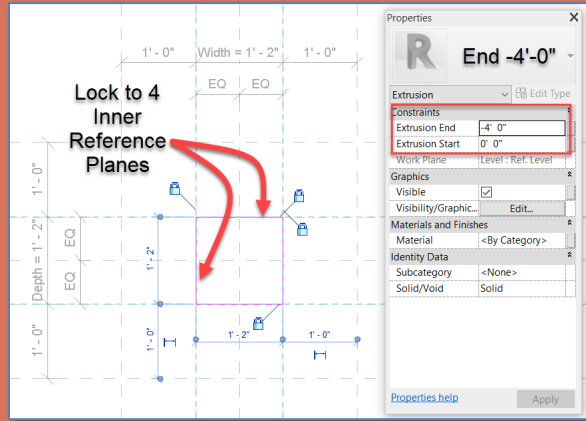
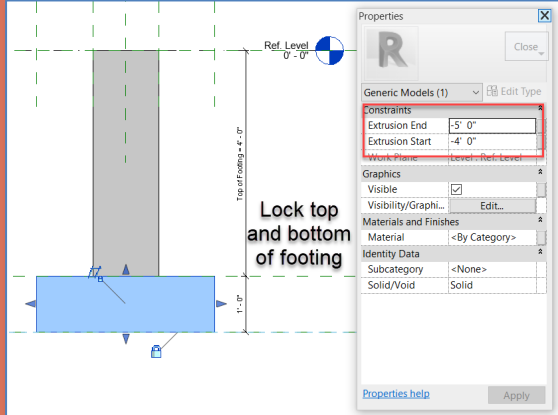
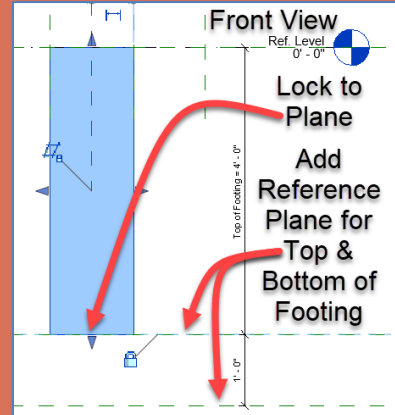
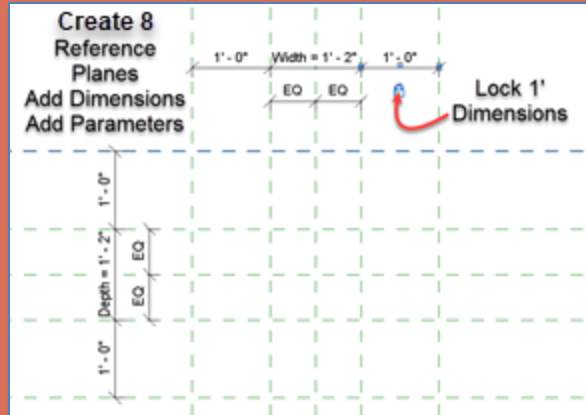
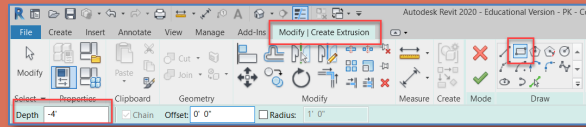

Concrete Isolated Footing with recess for Hold Down Bolts

- **Connections**
 - Video & sample
- **Isolated Footing**
 - Concrete Extrusions
 - Cone Shaped Void
- **Components**
 - Threaded Rod
 - Nut & Washer
- **Concrete Footing Family**
 - Add Threaded Rod
 - Add Nut
 - Add Washers
 - Position & Copy
- **Steel Connections Project File**
 - Align & Lock Footings to the Columns
- **Concrete Footing Family**
 - Add Level 1 Floor Slab
- **Develop Details**
 - Create Section Views
 - Provide a good name
 - Add Notes & Leaders
 - Add Dimensions
 - Add to your sheet

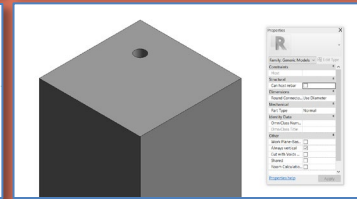
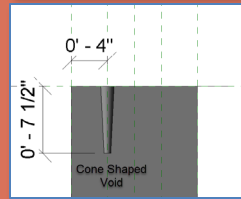
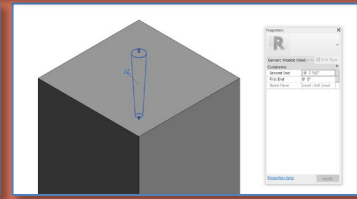
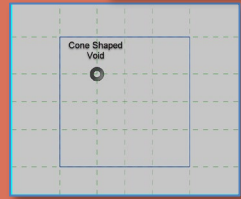
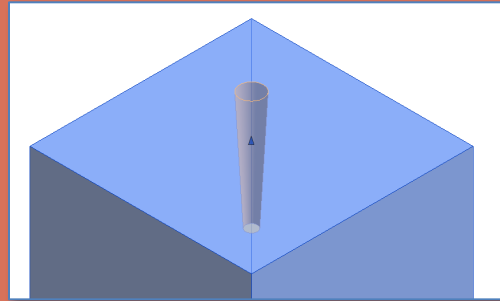
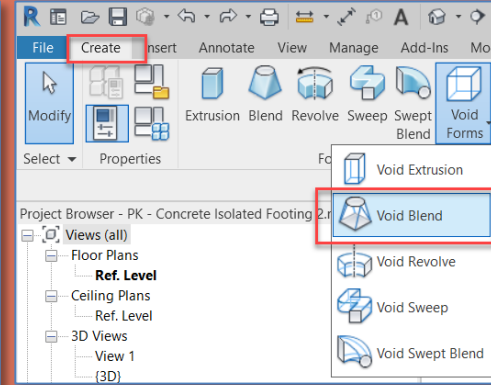
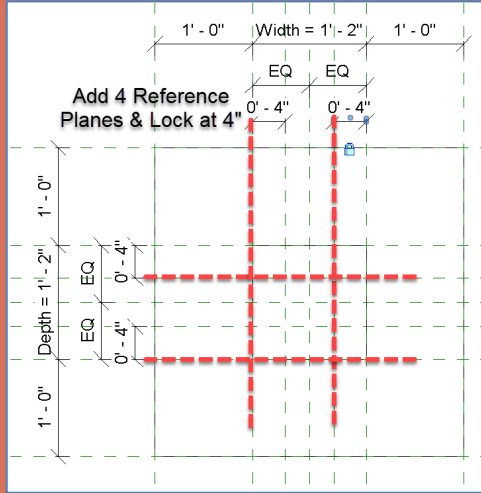

Create Cone Shaped Void

- *Create 4 Reference Planes & Lock at 4"*
- *Create > Void Blend*
 - *Top 3/4" Radius*
 - *Base 3/8" Radius*
 - *First End 0'-0"*
 - *Second End -7 1/2"*

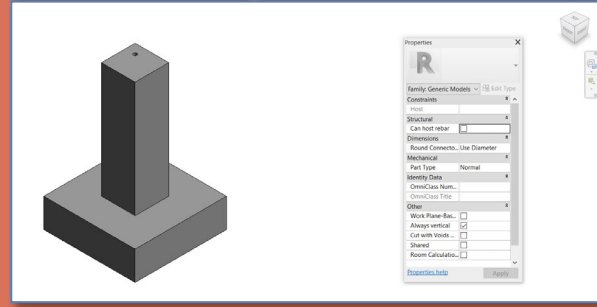
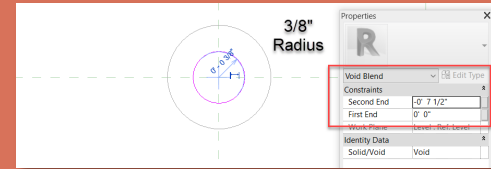
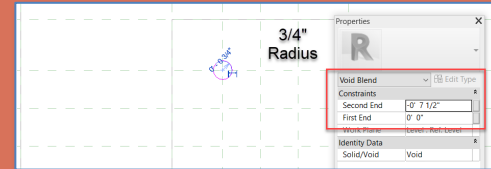

Create Threaded Rod, Nut & Washers (import)

- **Connections**
 - Video & sample
- **Isolated Footing**
 - Concrete Extrusions
 - Cone Shaped Void
- **Components**
 - Threaded Rod
 - Nut & Washer
- **Concrete Footing Family**
 - Add Threaded Rod
 - Add Nut
 - Add Washers
 - Position & Copy
- **Steel Connections**
- **Project File**
 - Align & Lock Footings to the Columns
- **Concrete Footing Family**
 - Add Level 1 Floor Slab
- **Develop Details**
 - Create Section Views
 - Provide a good name
 - Add Notes & Leaders
 - Add Dimensions
 - Add to your sheet

- *Hold-Down Bolt is made of a threaded rod, nut and washers*
- *Create > Extrusion (1' rod)*
- *Transfer Project Standards*
- *(Copy from your project file)*
- *Import Materials Library*
- *Select "Rod" and set Material Category*
- *Steel ASTM A992*

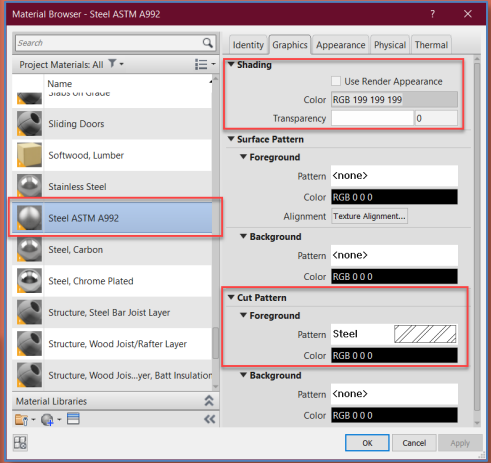
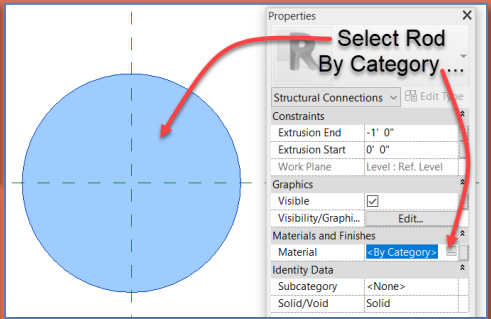
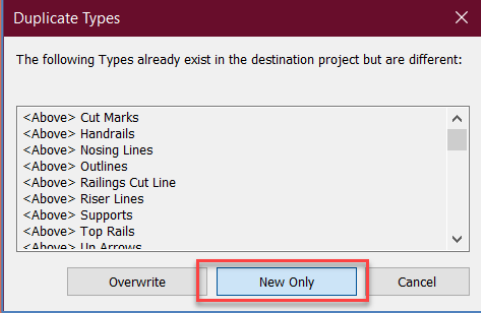
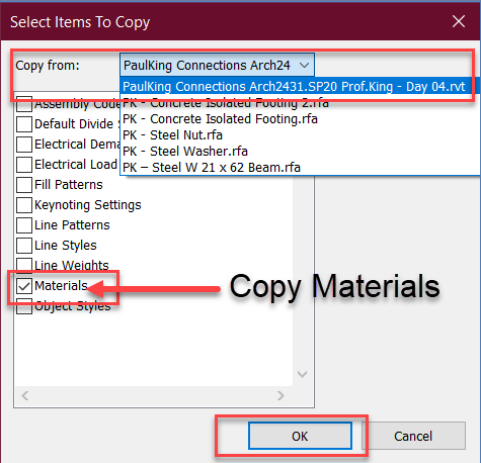
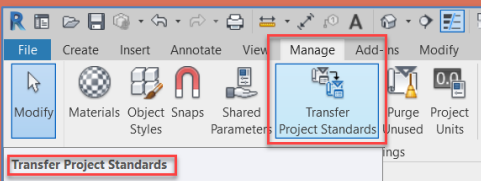
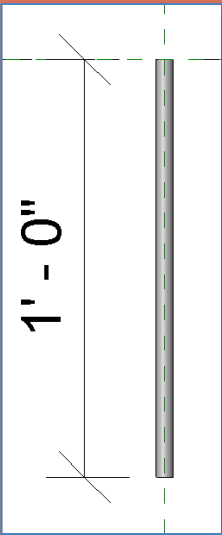
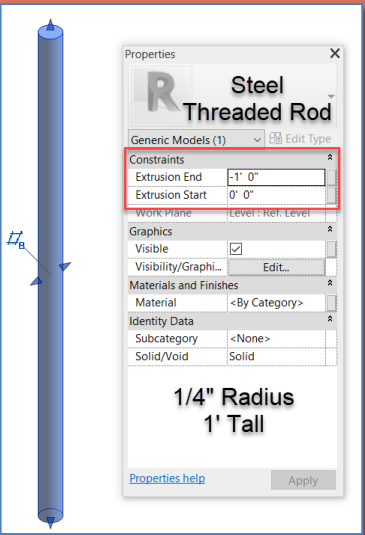

• *For all families get in the habit of assigning materials so they render and detail correctly*

Create Threaded Rod, Nut & Washers (import)

- **Connections**
 - Video & sample
- **Isolated Footing**
 - Concrete Extrusions
 - Cone Shaped Void
- **Components**
 - Threaded Rod
 - Nut & Washer
- **Concrete Footing Family**
 - Add Threaded Rod
 - Add Nut
 - Add Washers
 - Position & Copy
- **Steel Connections**
- **Project File**
 - Align & Lock Footings to the Columns
- **Concrete Footing Family**
 - Add Level 1 Floor Slab
- **Develop Details**
 - Create Section Views
 - Provide a good name
 - Add Notes & Leaders
 - Add Dimensions
 - Add to your sheet

• Because you need more than one of each component, create each in a separate family file – then combine these in the concrete footing family

- Steel Nut
- $\frac{1}{2}$ " radius with $\frac{1}{4}$ " radius hole x $\frac{3}{8}$ " high
- Steel Washer
- $\frac{3}{4}$ " radius with $\frac{5}{16}$ " radius hole x $\frac{1}{8}$ " high

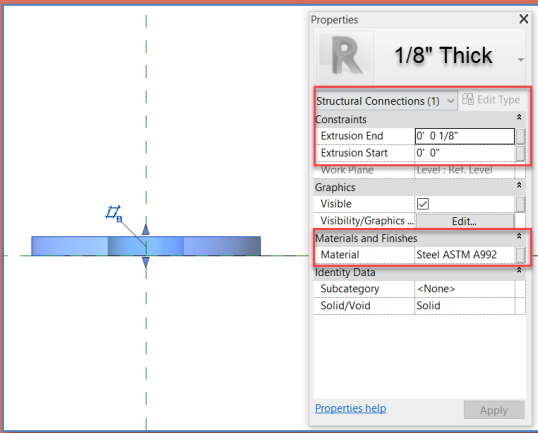
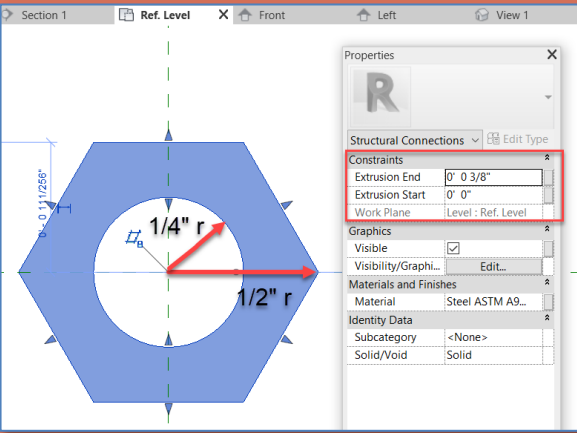
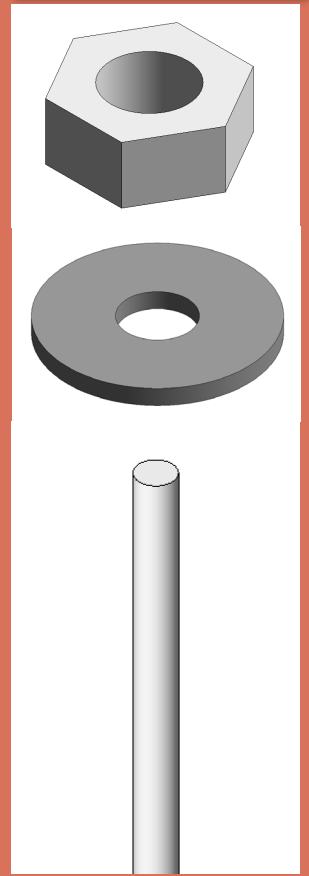
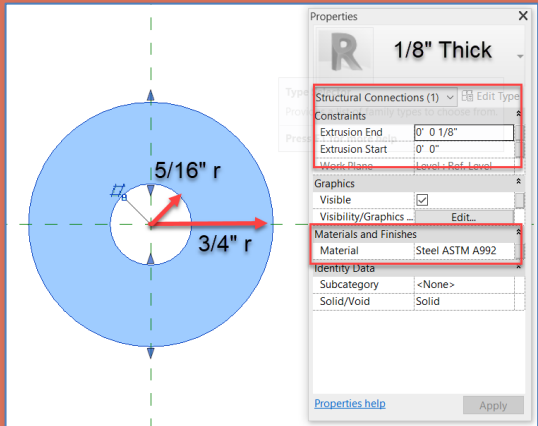
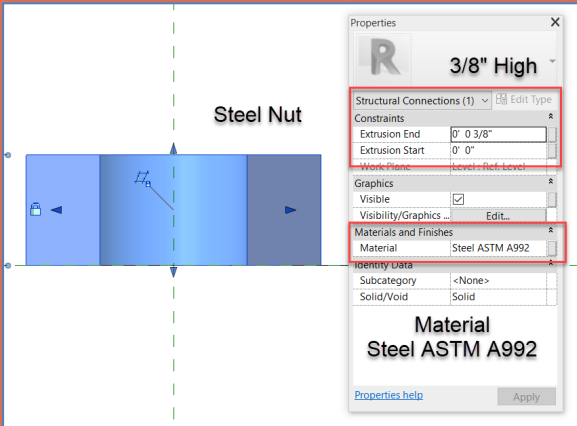
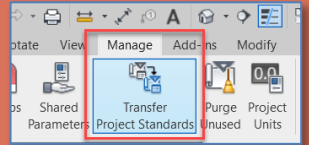

- **Connections**
 - Video & sample
- **Isolated Footing**
 - Concrete Extrusions
 - Cone Shaped Void
- **Components**
 - Threaded Rod
 - Nut & Washer
- **Concrete Footing Family**
 - Add Threaded Rod
 - Add Nut
 - Add Washers
 - Position & Copy
- **Steel Connections**
- **Project File**
 - Align & Lock Footings to the Columns
- **Concrete Footing Family**
 - Add Level 1 Floor Slab
- **Develop Details**
 - Create Section Views
 - Provide a good name
 - Add Notes & Leaders
 - Add Dimensions
 - Add to your sheet

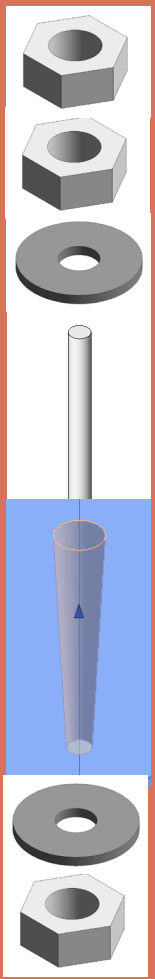

Lock Nut
 Nut
 Washer
 Threaded Rod
 Cone Shaped Void
 Washer
 Nut

Assemble Components in Concrete Footing Family

- Load the Threaded Rod, Nut & Washer into the Concrete Footing Family

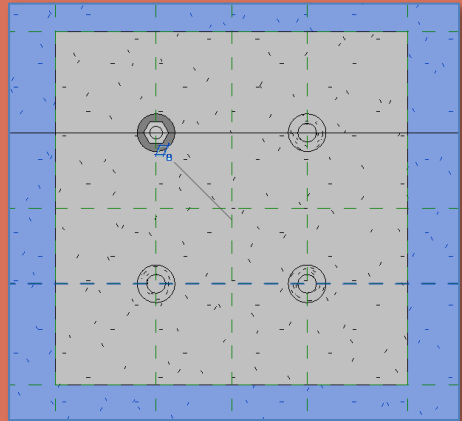

- Locate each component and make certain each is locked to the correct reference planes
- Set the material for the footing to concrete, cast-in-place
- Load the Footing Family into the project file.
- All sub families will load as well

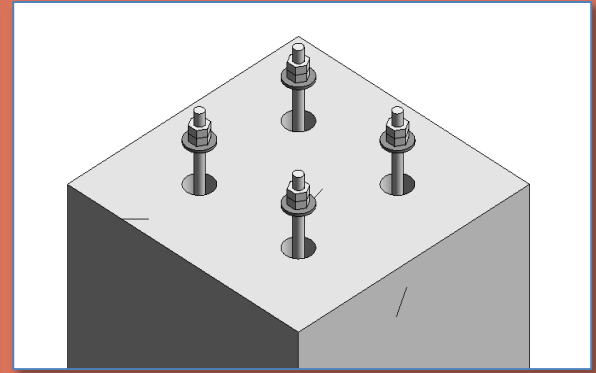
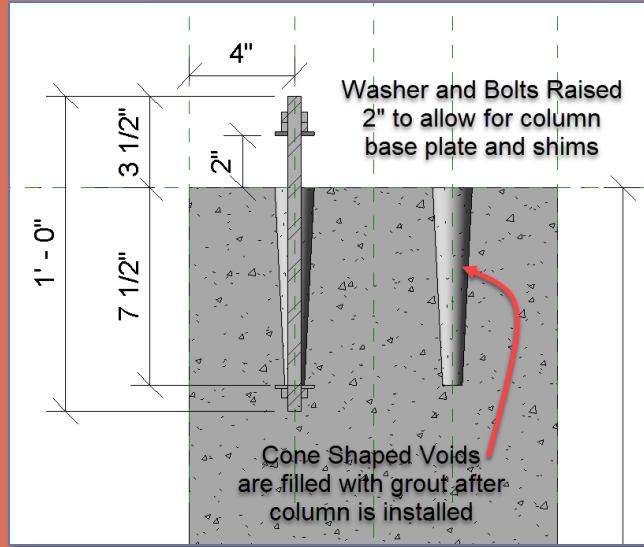

Visible	<input checked="" type="checkbox"/>
Visibility/Graphics Overrides	Edit...
Materials and Finishes	^
Material	Concrete, Cast-in-Place gray
Identity Data	^

Align & Lock the Concrete Footing to the Column

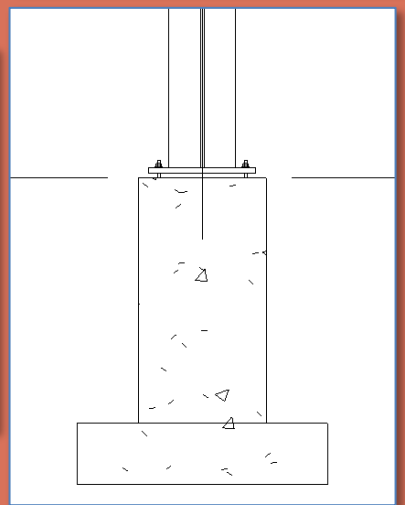
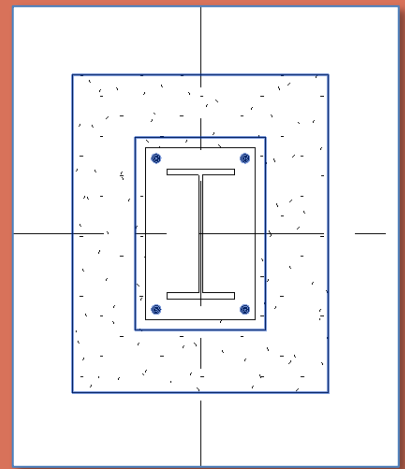
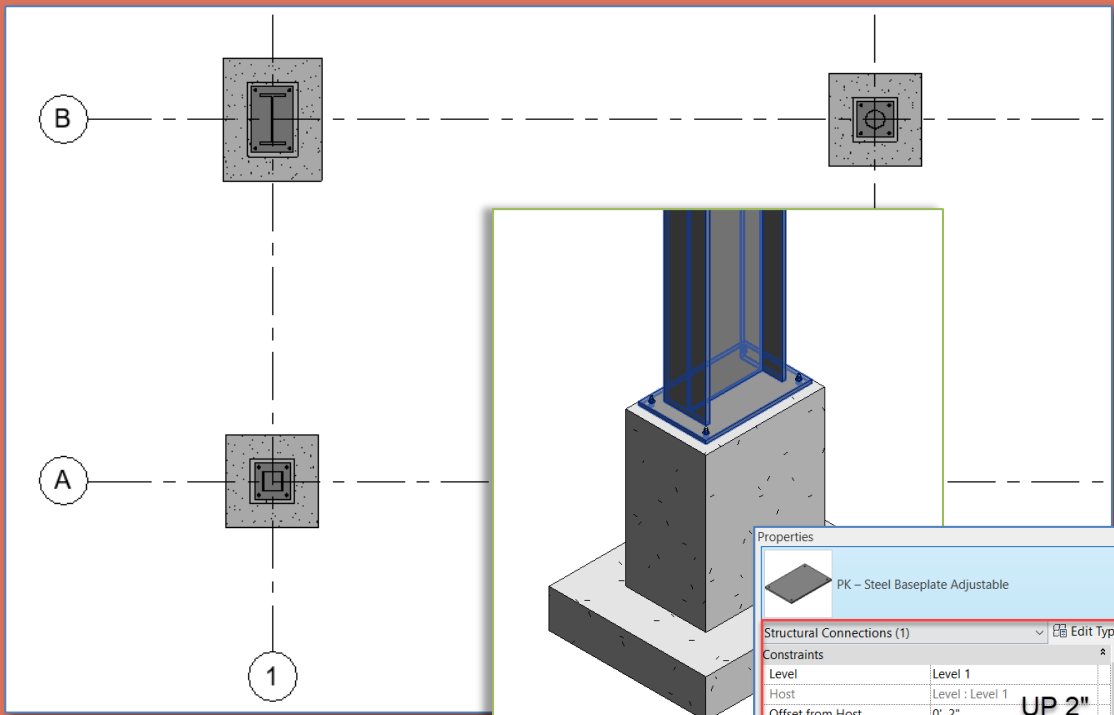

- *Work on Structure Level 1*
- *Add Footings*
- *Align & Lock*
- *Top of Footing is at Level 1*

- *Base plate of column must be raised 2" to allow for shims and grout*
- *Column must be 2" shorter (from 15'-0" down to 14'-10")*

Lecture Title

- **Connections**
 - Video & sample
- **Isolated Footing**
 - Concrete Extrusions
 - Cone Shaped Void
- **Components**
 - Threaded Rod
 - Nut & Washer
- **Concrete Footing Family**
 - Add Threaded Rod
 - Add Nut
 - Add Washers
 - Position & Copy
- **Steel Connections**
- **Project File**
 - Align & Lock Footings to the Columns
- **Concrete Footing Family**
 - Add Level 1 Floor Slab
- **Develop Details**
 - Create Section Views
 - Provide a good name
 - Add Notes & Leaders
 - Add Dimensions
 - Add to your sheet

- Connections
 - Video & sample
- Isolated Footing
 - Concrete Extrusions
 - Cone Shaped Void
- Components
 - Threaded Rod
 - Nut & Washer
- Concrete Footing Family
 - Add Threaded Rod
 - Add Nut
 - Add Washers
 - Position & Copy
- Steel Connections
 - Project File
 - Align & Lock Footings to the Columns
- Concrete Footing Family
 - Add Level 1 Floor Slab
- Develop Details
 - Create Section Views
 - Provide a good name
 - Add Notes & Leaders
 - Add Dimensions
 - Add to your sheet

Add a Concrete Floor Slab on Level 1 Structural

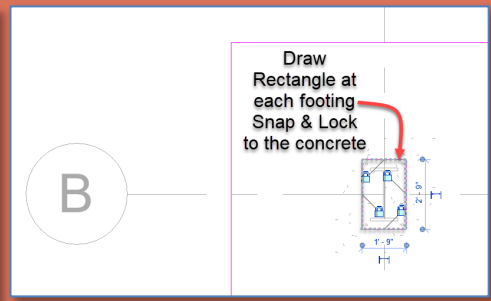
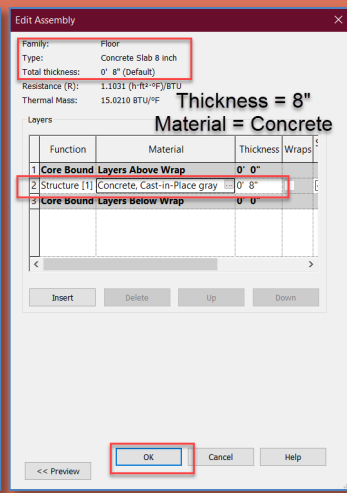
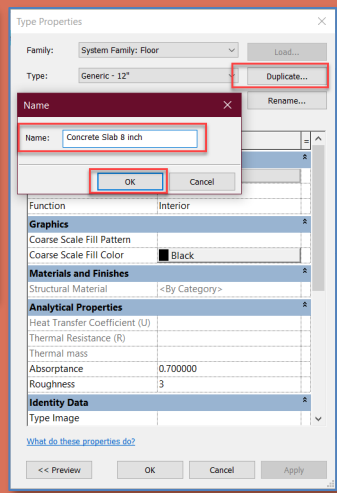
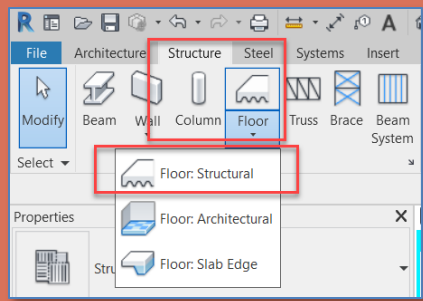

- Create a Structural Floor
- Select Generic 12"
- Duplicate > Concrete Slab 8 inch
- Structure > Thickness = 8"
- Material = Concrete

- Draw Rectangle with 6' offset from grid intersection to grid intersection
- (use space to flip offset direction)
- Add Rectangle at each footing – snap & lock to the concrete – not the steel

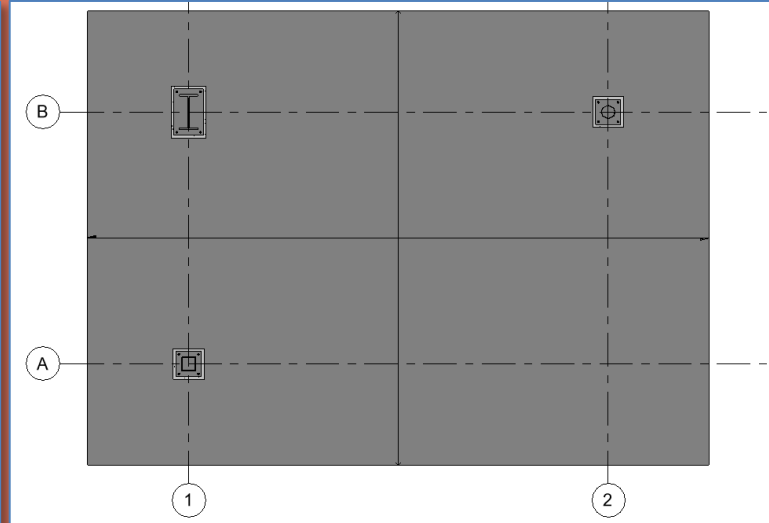
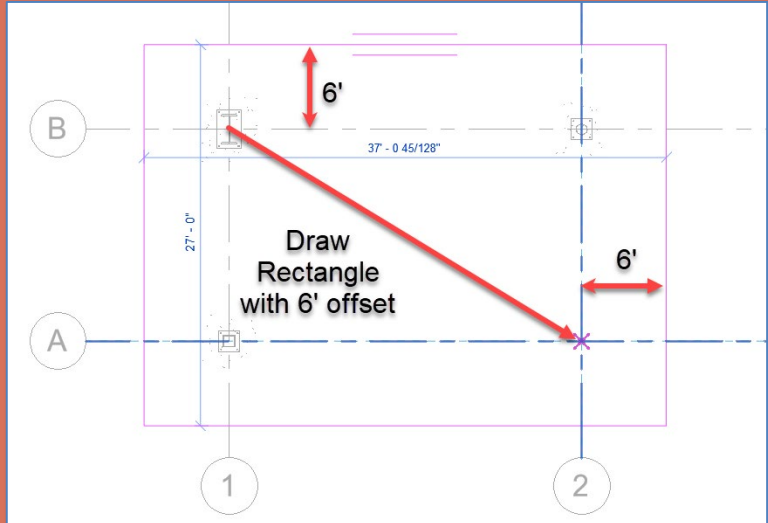

Modify Base Plate Elevations as needed – add details

- **Connections**
 - Video & sample
- **Isolated Footing**
 - Concrete Extrusions
 - Cone Shaped Void
- **Components**
 - Threaded Rod
 - Nut & Washer
- **Concrete Footing Family**
 - Add Threaded Rod
 - Add Nut
 - Add Washers
 - Position & Copy
- **Steel Connections**
- **Project File**
 - Align & Lock Footings to the Columns
- **Concrete Footing Family**
 - Add Level 1 Floor Slab
- **Develop Details**
 - Create Section Views
 - Provide a good name
 - Add Notes & Leaders
 - Add Dimensions
 - Add to your sheet

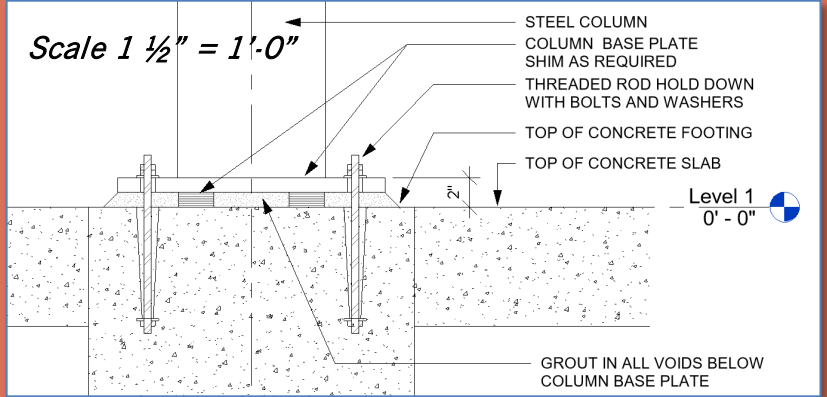
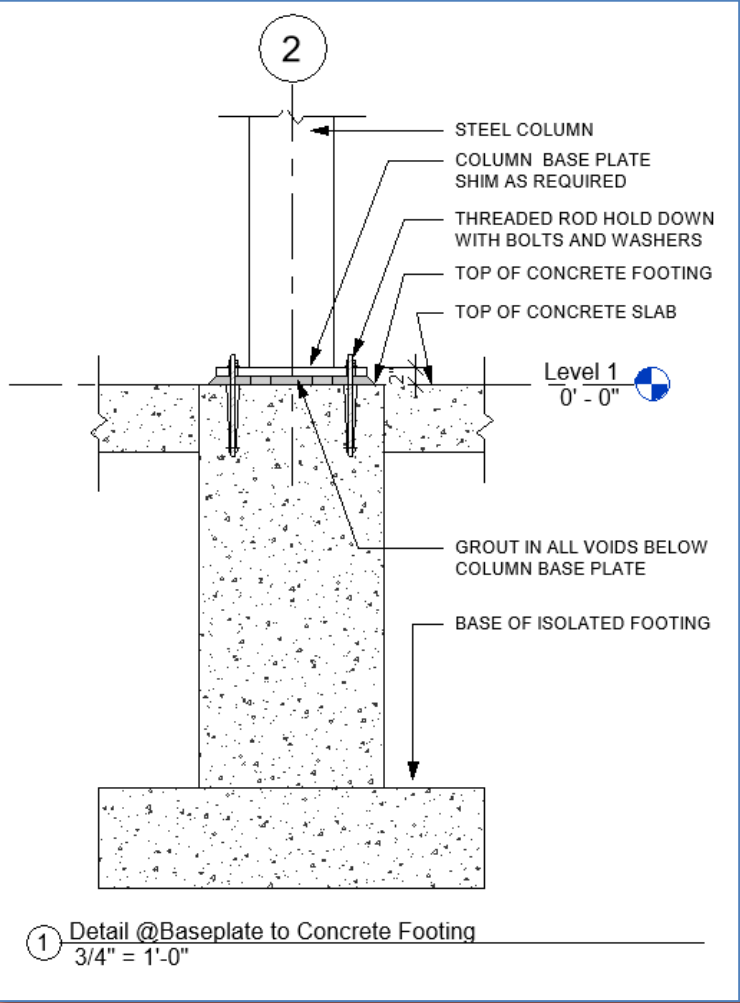

- *Develop a detail of the footing condition*
- *Note the 2" distance from top of plate to concrete*
- *Top of Footing can also be recessed to allow for finish flooring to cover*

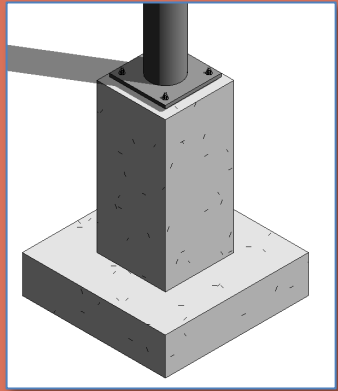
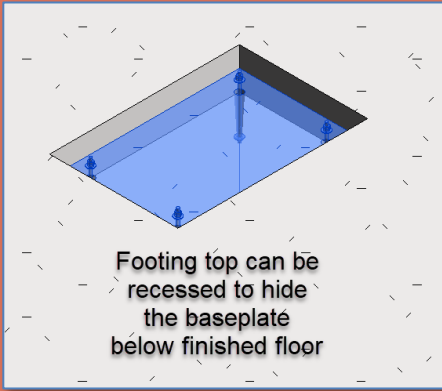

Lecture Title

• Connections

- Video & sample

• Isolated Footing

- Concrete Extrusions
- Cone Shaped Void

• Components

- Threaded Rod
- Nut & Washer

• Concrete

Footing Family

- Add Threaded Rod
- Add Nut
- Add Washers
- Position & Copy

• Steel

Connections

Project File

- Align & Lock Footings to the Columns

• Concrete

Footing Family

- Add Level 1 Floor Slab

• Develop Details

- Create Section Views
- Provide a good name
- Add Notes & Leaders
- Add Dimensions
- Add to your sheet

Isometric views of Completed Column & Isolated Footings

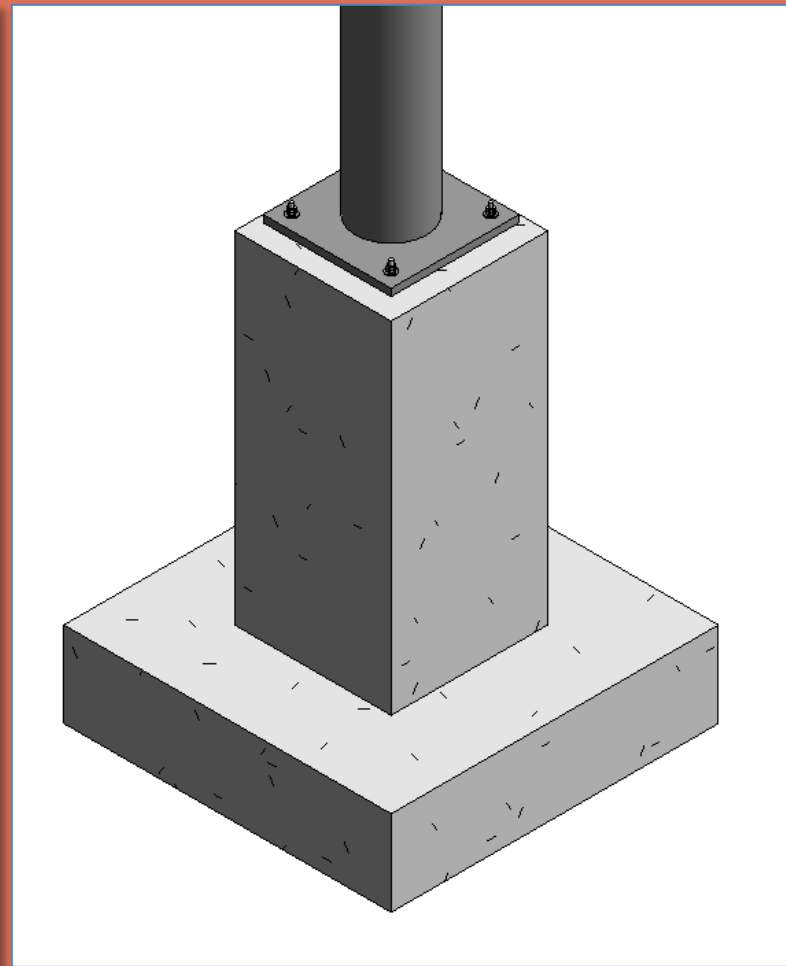
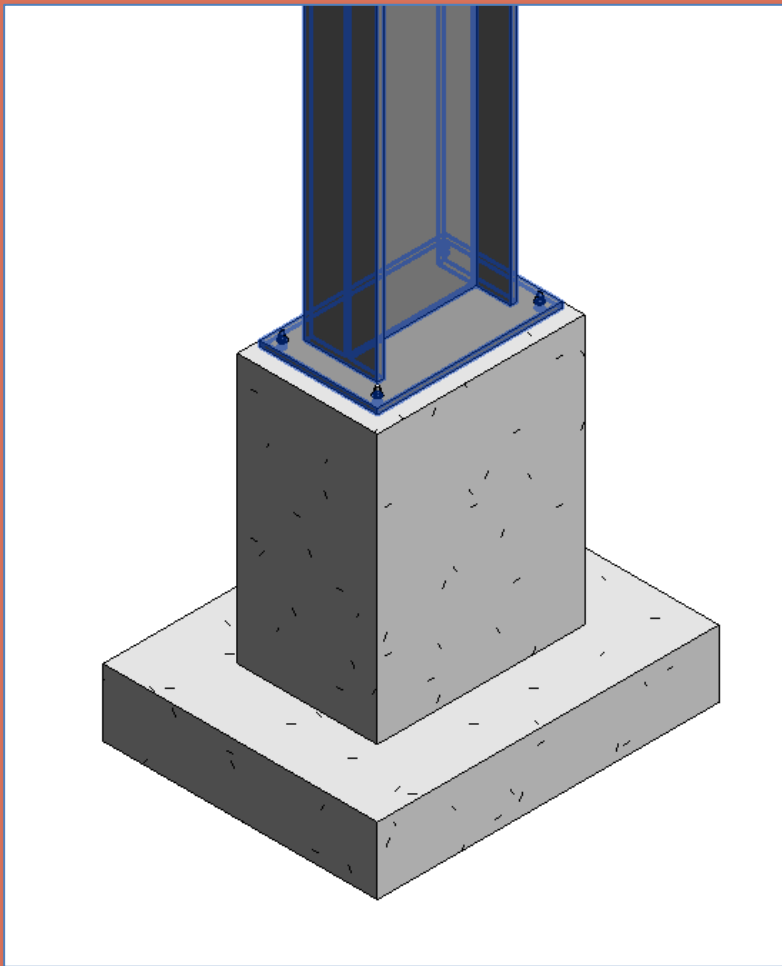



That's all Folks!