



AUTODESK® REVIT™
DESIGN · CONNECT · OPTIMIZE



ARCH 2431 Building Technology III Steel Assembly & Building Information Modeling (BIM) with Revit

Steel Connections Series

- #1 Introduction to Columns & Beams
- #2 Column Base Plates
- #3 Photos & Videos – Connections & Fasteners
- #4 Concrete footing to baseplate connection
- #5 Fin & Splice Plates – Notched Beams
- #6 Diagonal Bracing

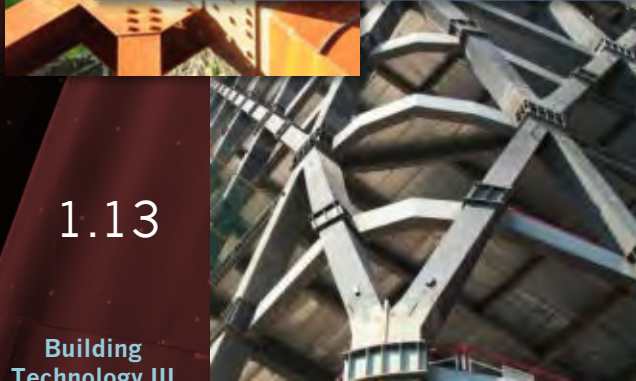
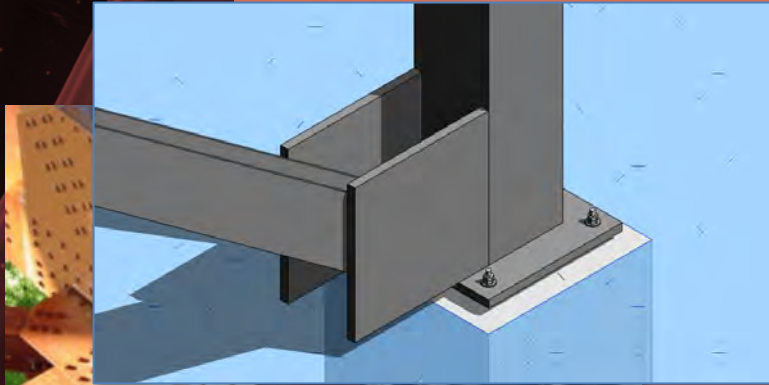

1.13

Building
Technology III

Prof. Paul C. King, Course Coordinator
Prof. Blake Kurasek
Prof. Justin Sherman
Prof. Jieun Yang

Pking@CityTech.Cuny.Edu
Bkurasek@CityTech.Cuny.Edu
Jsherman@CityTech.Cuny.Edu
Jyang@CityTech.Cuny.Edu

Diagonal Bracing Connections

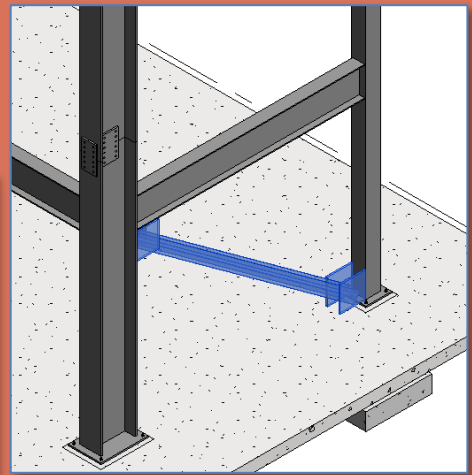
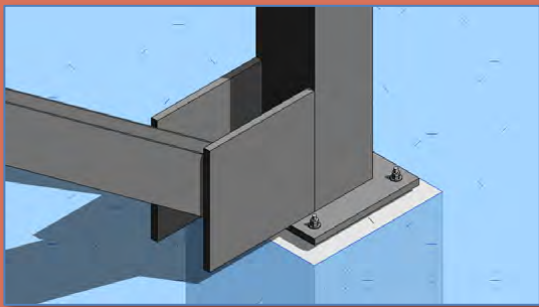

• Place & Align

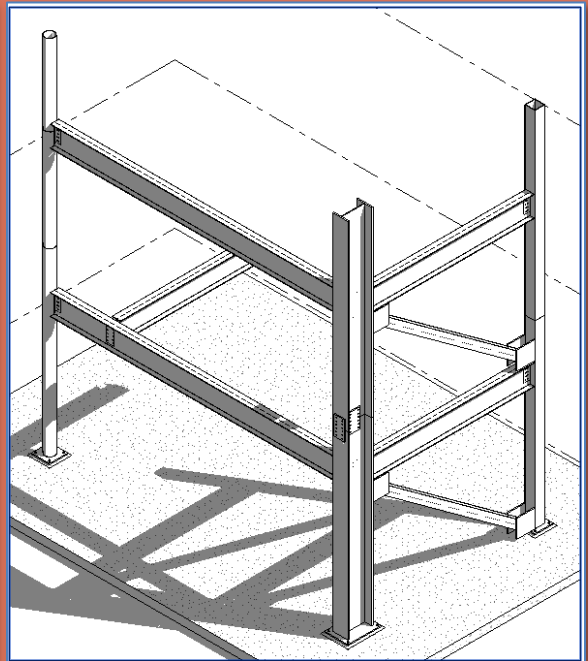
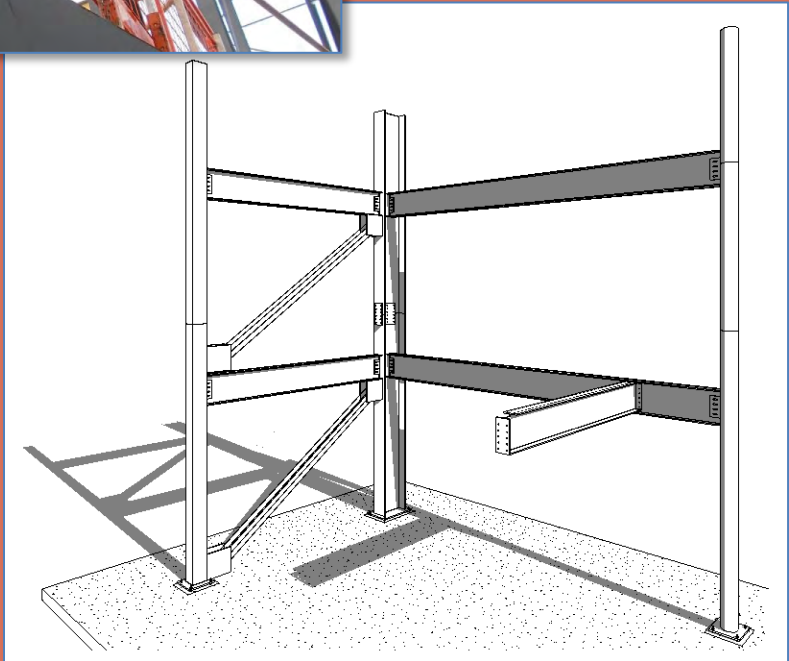

Diagonal Bracing

- **Connections**
- **New 3D Family**
 - Structural Framing – Beams & Braces
- **Edit**
 - W18 x 50
 - Rotate 90
 - Reference Plans & Parameters
 - Save & Name
 - Load into Project
- **Position**
 - Place & Align
 - Rotate from side
- **New 3D Family**
 - Generic
 - Save & Name
 - Load into Project
- **Position**
 - Place & Align
 - Copy
- **Isometric Views**
- **Sheet**

Diagonal Bracing Connections

Diagonal bracing and solid concrete shear walls add lateral stability to buildings. Building made of concrete typically use only concrete shear walls. Steel frame buildings may either make use of concrete shear walls or diagonal bracing connected to the steel beam and column structure.



- Connections
- **New 3D Family**
 - Structural Framing – Beams & Braces
- Edit
 - W18 x 50
 - Rotate 90
 - Reference Plans & Parameters
 - Save & Name
 - Load into Project
- Position
 - Place & Align
 - Rotate from side
- **New 3D Family**
 - Generic
 - Save & Name
 - Load into Project
- Position
 - Place & Align
 - Copy
- Isometric Views
- Sheet

Creating a new 3D Family File

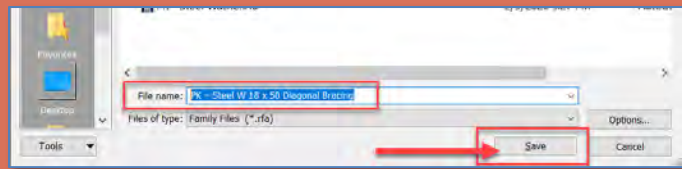
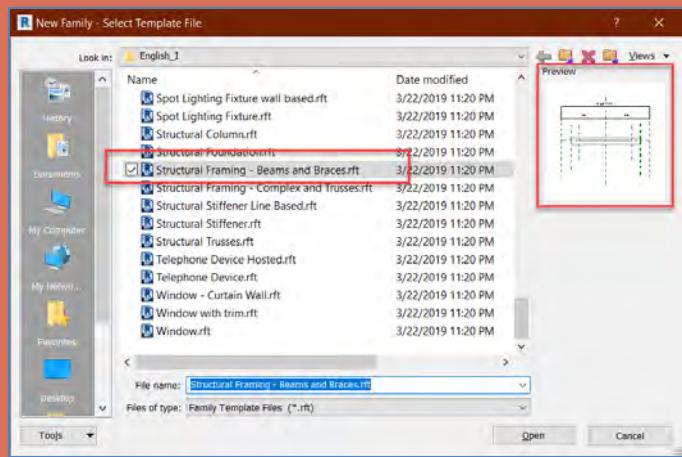
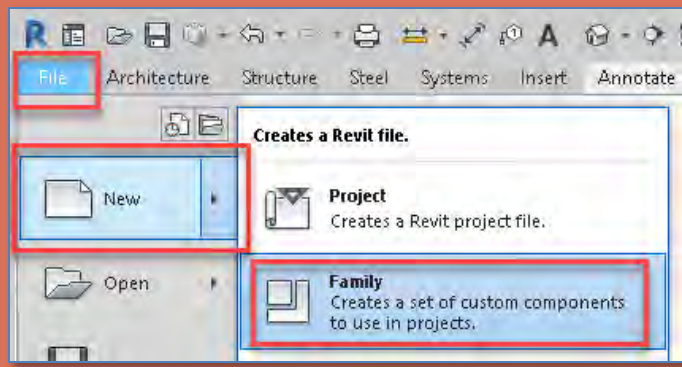

- We will repeat this for each component of the Steel Connection Assembly

- **Create a new Family**
 - File > New > Family
 - **Structural Framing – Beams & Braces**

- **Save and Name the File**

- Select an appropriate directory

- Name the file as follows:
 - Initials- Description
 - *PK – Steel W 18 x 50 Diagonal Bracing*

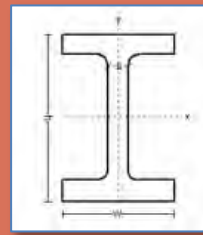

Designation	Dimensions						
	Imperial (in x lb/ft)	Depth h (in)	Width w (in)	Web Thickness tw (in)	Flange Thickness tf (in)	Sectional Area (in ²)	Weight (lb/ft)
W 18 x 60	18.2	7.56	0.415	0.695	17.6	984	50.1
W 18 x 55	18.1	7.53	0.390	0.630	16.2	890	44.9
W 18 x 50	18	7.5	0.355	0.570	14.7	800	40.1
W 18 x 40	18.1	6.00	0.360	0.505	13.5	712	36.8

Steel Connections

Diagonal Bracing

- Connections
- New 3D Family
 - Structural Framing – Beams & Braces
- Edit
 - W18 x 50
 - Rotate 90
 - Reference Plans & Parameters
 - Save & Name
 - Load into Project

- Position
 - Place & Align
 - Rotate from side

- New 3D Family
 - Generic
 - Save & Name
 - Load into Project

- Position
 - Place & Align
 - Copy

- Isometric Views
- Sheet

Structural Framing Beams & Bracing Family

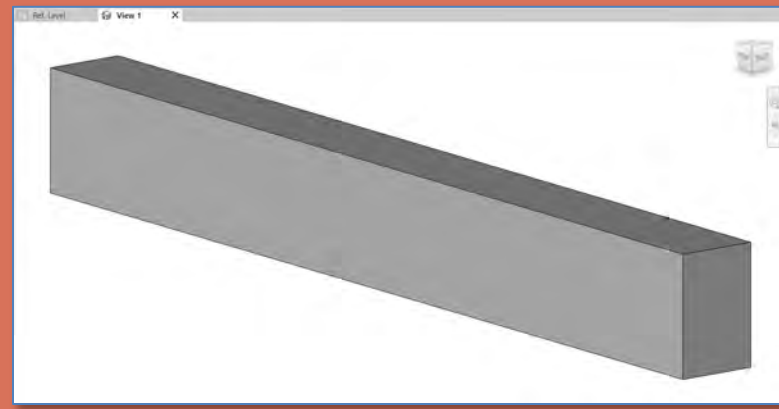
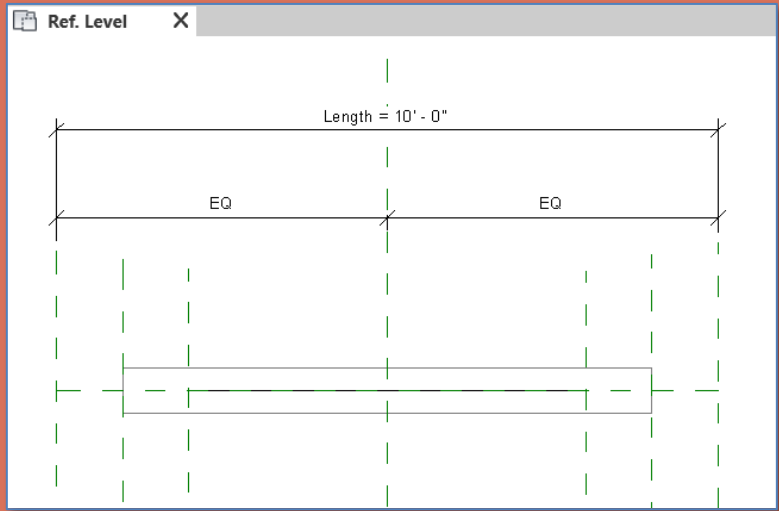

W 18 x 50 for diagonal bracing beam will be rotated 90 degrees on axis



- Connections
- New 3D Family
 - Structural Framing – Beams & Braces
- Edit
 - W18 x 50
 - Rotate 90
 - Reference Plans & Parameters
 - Save & Name
 - Load into Project

- Position
 - Place & Align
 - Rotate from side

- New 3D Family
 - Generic
 - Save & Name
 - Load into Project

- Position
 - Place & Align
 - Copy

- Isometric Views
- Sheet

W18 x 50 Beam for Diagonal Bracing

Use W 18 x 50 for diagonal bracing beam will be rotated 90 degrees on axis

Depth = 8"
Web .355"

Width=7.5"
Flange = 0.570"

Designation Imperial (in x lb/ft)	Depth h (in)	Width W (in)	Web Thickness t _w (in)	Flange Thickness t _f (in)	Sectional Area (in ²)	Weight (lb/ft)	Static Parameters			
							Moment of Inertia I _x (in ⁴)	I _y (in ⁴)	Elastic Section Modulus S _x (in ³)	S _y (in ³)
W 27 x 178	27.8	14.09	0.725	1.190	52.3	178	6990	555	502	78.8
W 27 x 161	27.6	14.02	0.660	1.080	47.4	161	6280	497	455	70.9

W 18 x 65	18.4	7.59	0.450	0.750	19.1	65	1070	54.8	117	14.4
W 18 x 60	18.2	7.56	0.415	0.695	17.6	60	984	50.1	108	13.3
W 18 x 55	18.1	7.53	0.390	0.630	16.2	55	890	44.9	96.3	11.9
W 18 x 50	18	7.5	0.355	0.570	14.7	50	800	40.1	88.9	10.7
W 18 x 46	18.1	6.06	0.360	0.605	13.5	46	742	22.5	78.8	7.4
W 18 x 40	17.9	6.02	0.315	0.525	11.8	40	612	19.1	68.4	6.4

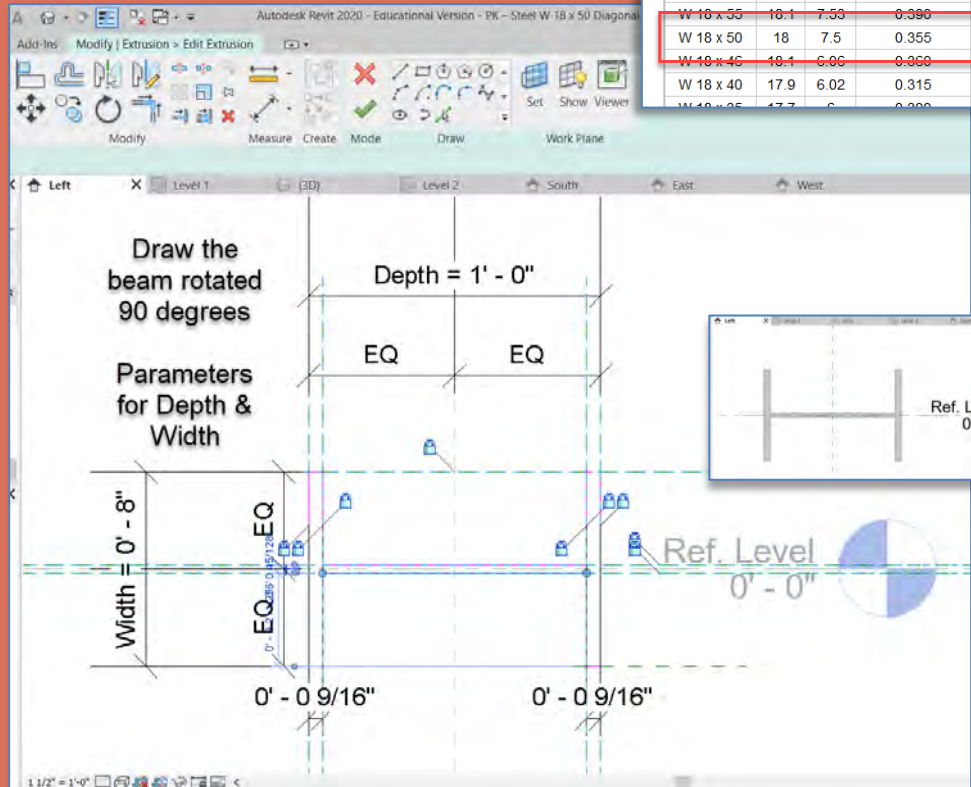

To make it easier to work set the Depth to 1'-0" and the Width to 8"

Create the beam rotated 90 degrees

Add parameters for Depth and Width while editing the extrusion

Adjust the width to 8"

- Connections
- New 3D Family
 - Structural Framing – Beams & Braces
- Edit
 - W18 x 50
 - Rotate 90
 - Reference Plans & Parameters
 - Save & Name
 - Load into Project
- Position
 - Place & Align
 - Rotate from side

- New 3D Family
 - Generic
 - Save & Name
 - Load into Project
- Position
 - Place & Align
 - Copy

- Isometric Views
- Sheet

Place & Align diagonal bracing (Structure Level 2)

- Level 2 Structure View
- Drag Diagonal Brace into view
- Space bar to rotate and place

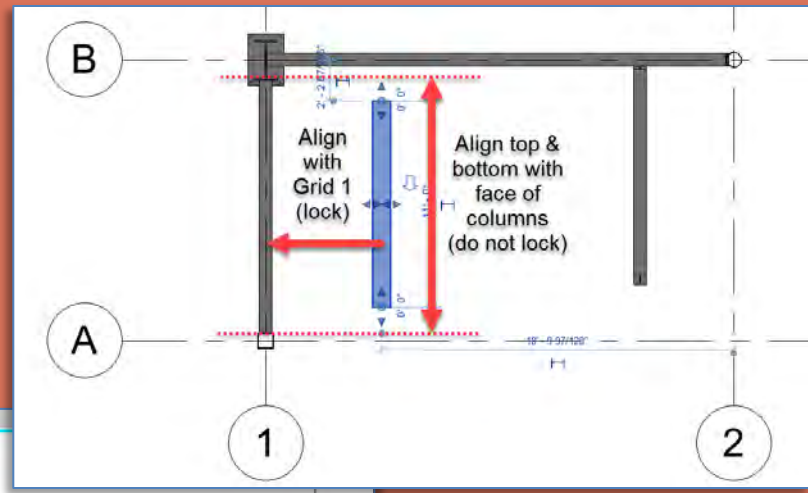

Level 2 Structure View

Use Space Bar to Rotate 90 Degrees

PK - Steel W 18 x 50 Diagonal Bracing

Constraints	
Reference Level	Level 2
Work Plane	Level - Level 2
Start Level Offset	0' 0"
End Level Offset	0' 0"
Orientation	Normal
Cross-Section Rotation	0.00°
Geometric Position	
Start Extension	0' 0"

Align top & bottom to face of columns (do not lock)

Align with Grid 1

- Connections
- New 3D Family
 - Structural Framing – Beams & Braces
- Edit
 - W18 x 50
 - Rotate 90
 - Reference Plans & Parameters
 - Save & Name
 - Load into Project
- Position
 - Place & Align
 - Rotate from side

- New 3D Family
 - Generic
 - Save & Name
 - Load into Project
- Position
 - Place & Align
 - Copy
- Isometric Views
- Sheet

Rotate the Beam from South View

Start Level – 10'6" End Level – 4'0"

Properties

PK – Steel W 18 x 50 Diagonal Bracing

Structural Framing (Other) (1) Edit Type

Constraints

Reference Level	Level 2
Start Level Offset	-0' 6"
End Level Offset	-0' 6"
Cross-Section Rotation	0.00°

Geometric Position

Start Extension	1' 3 255/256"
End Extension	5' 7 129/256"
yz Justification	Uniform

Properties help Apply

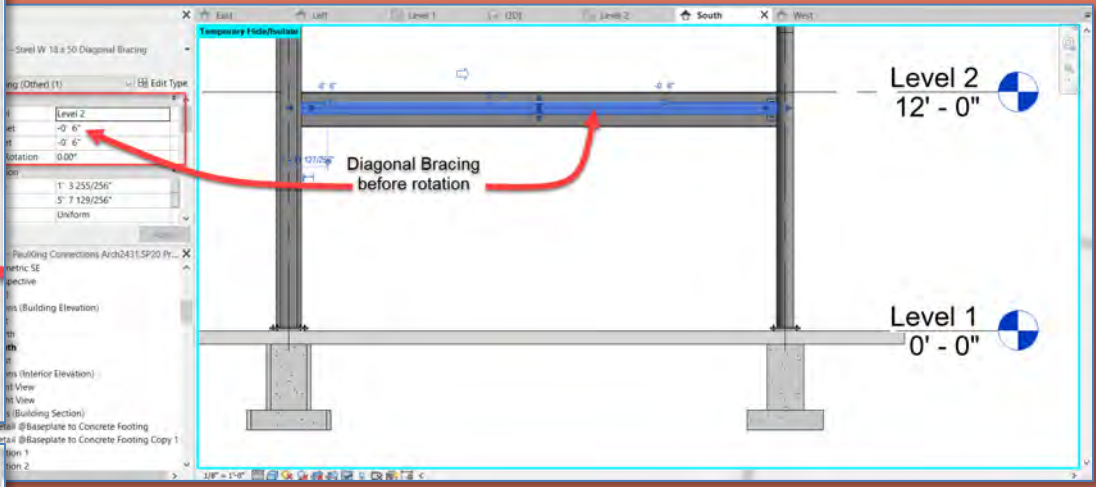

Properties

PK – Steel W 18 x 50 Diagonal Bracing

Structural Framing (Other) (1) Edit Type

Constraints

Reference Level	Level 2
Start Level Offset	-10' 6"
End Level Offset	-4' 0"
Cross-Section Rotation	0.00°

Geometric Position

Start Extension	1' 3 255/256"
End Extension	5' 7 129/256"
yz Justification	Uniform

Properties help Apply

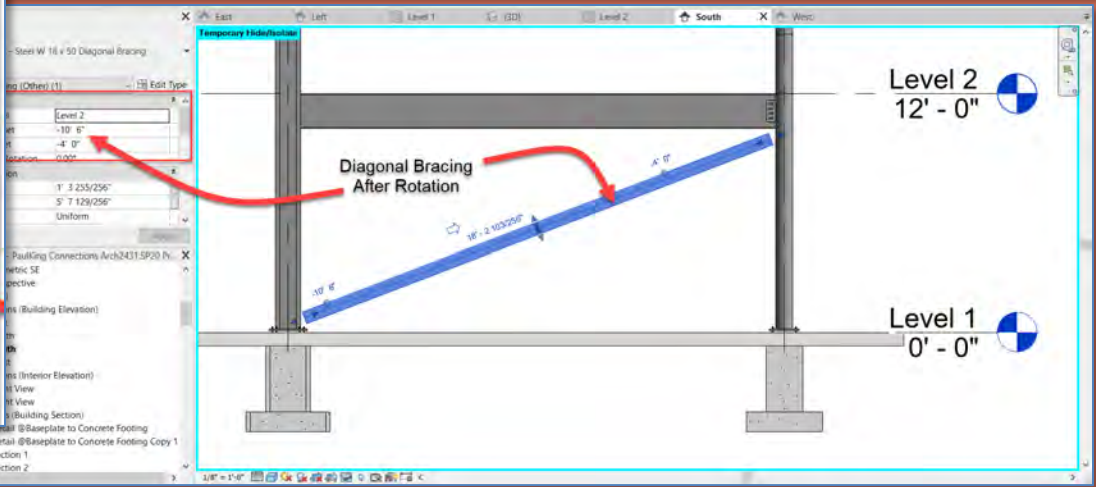

Create New Family for Diagonal Bracing Endplate

Begin with Generic

Parameters for:
Height = 1'0
Length = 1'6
Thickness = 1"

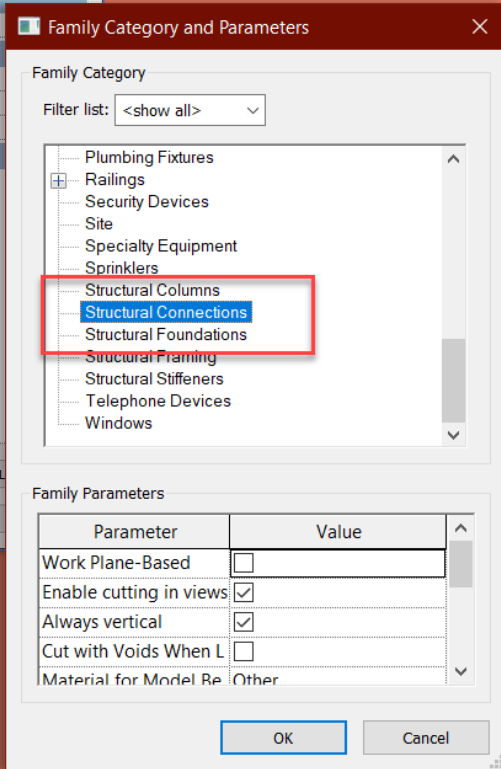
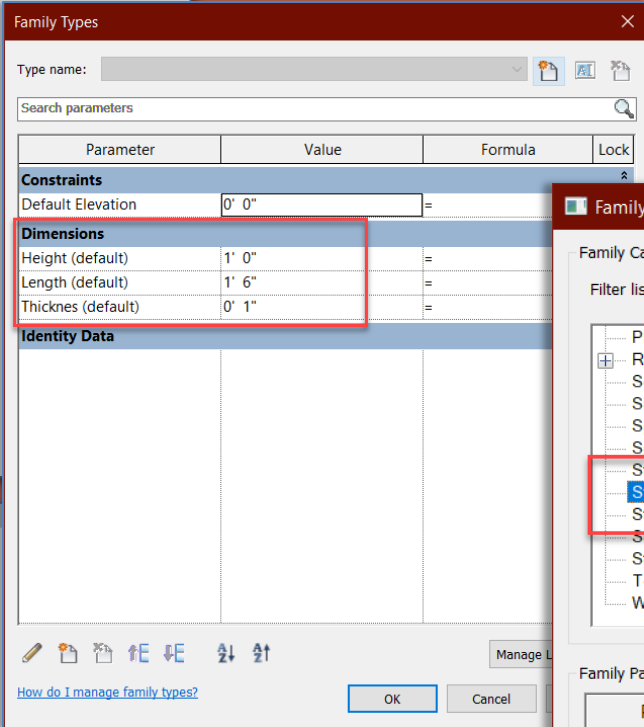
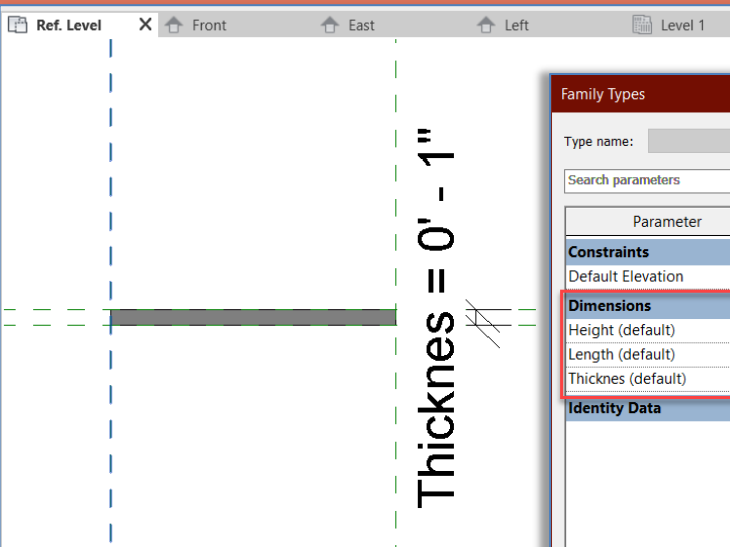

Family Category
Structural Connections

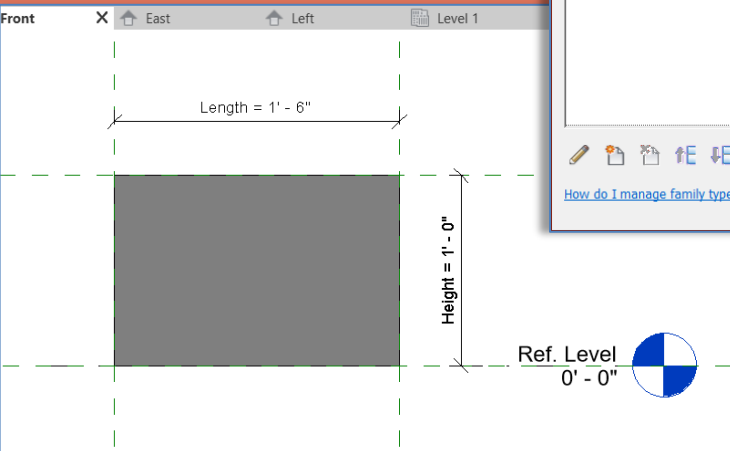

Steel Connections

Diagonal Bracing

- Connections
- New 3D Family
 - Structural Framing – Beams & Braces
- Edit
 - W18 x 50
 - Rotate 90
 - Reference Plans & Parameters
 - Save & Name
 - Load into Project
- Position
 - Place & Align
 - Rotate from side

New 3D Family

- Generic
- Save & Name
- Load into Project

Position

- Place & Align
- Copy

Isometric Views

Sheet

Create New Family for Diagonal Bracing Endplate

Level 1 Structure View

Drag Family close to column

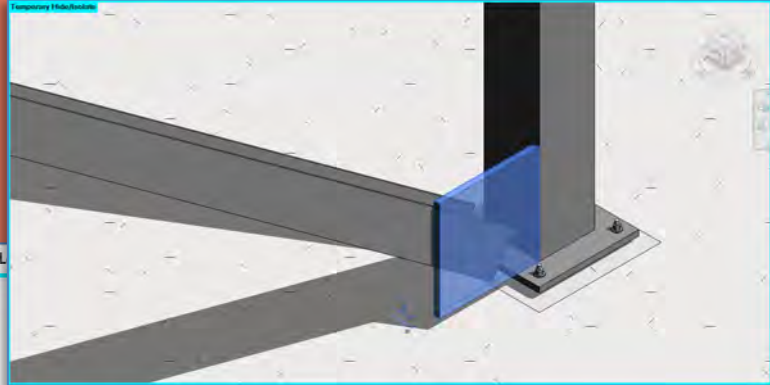

Properties

PK - Steel Diagonal Bracing EndPlate

Structural Connections (1)

Constraints

Default Elevation 0' 0"

Identity Data

Type Image

Keynote

Model

Manufacturer

Type Comments

URL

Project Browser - PaulKing Connections Arch2431.SP20 Pr...

- PK - Steel Baseplate Adjustable
 - PK - Steel Baseplate Adjustable
- PK - Steel Diagonal Bracing EndPlate
 - PK - Steel Diagonal Bracing EndPlate**
- PK - Steel Fin Plate Slotted
 - PK - Steel Fin Plate Slotted
- PK - Steel Splice Plate Double
 - PK - Steel Splice Plate Double
- PK - Steel W 21 x 62 Beam
- PK - Steel W 21 x 62 Beam Notched
- PK - Steel W 24 x 162
- PK - Steel W 24 x 162 Baseplate
 - PK - Steel W 24 x 162 Baseplate
- Structural Foundations

Level 1 Structure

Drag Endplate close to column

A

1

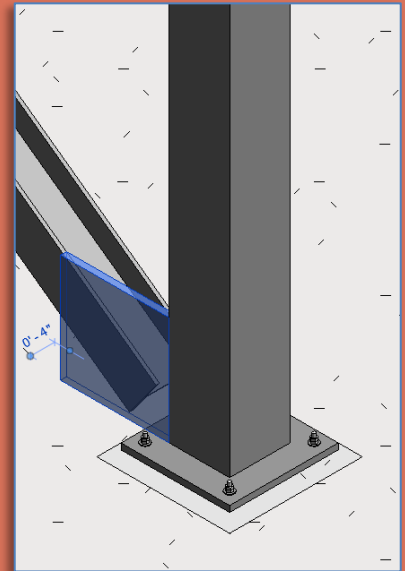
A 2D structural view of a column base. A vertical column is shown on a square baseplate. A diagonal bracing endplate is shown as a thin gray line being dragged towards the column. A red arrow points from the endplate in the Project Browser to the endplate in the structure view. A circle labeled 'A' is around the column base, and a circle labeled '1' is around the column shaft.

Steel Connections

Diagonal Bracing

- Connections
- New 3D Family
 - Structural Framing – Beams & Braces
- Edit
 - W18 x 50
 - Rotate 90
 - Reference Plans & Parameters
 - Save & Name
 - Load into Project

• Position

- Place & Align
- Rotate from side

• New 3D Family

- Generic
- Save & Name
- Load into Project

• Position

- Place & Align
- Copy

• Isometric Views

• Sheet

- Connections
- New 3D Family
 - Structural Framing – Beams & Braces
- Edit
 - W18 x 50
 - Rotate 90
 - Reference Plans & Parameters
 - Save & Name
 - Load into Project

- Position
 - Place & Align
 - Rotate from side

- New 3D Family
 - Generic
 - Save & Name
 - Load into Project

- Position
 - Place & Align
 - Copy

- Isometric Views
- Sheet

Add Diagonal Bracing Endplate

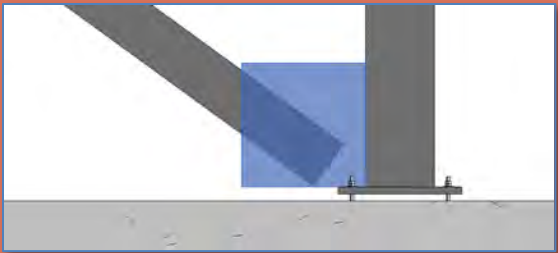

- Align endplate with face of brace and face of square column
- Copy endplate to other side of brace

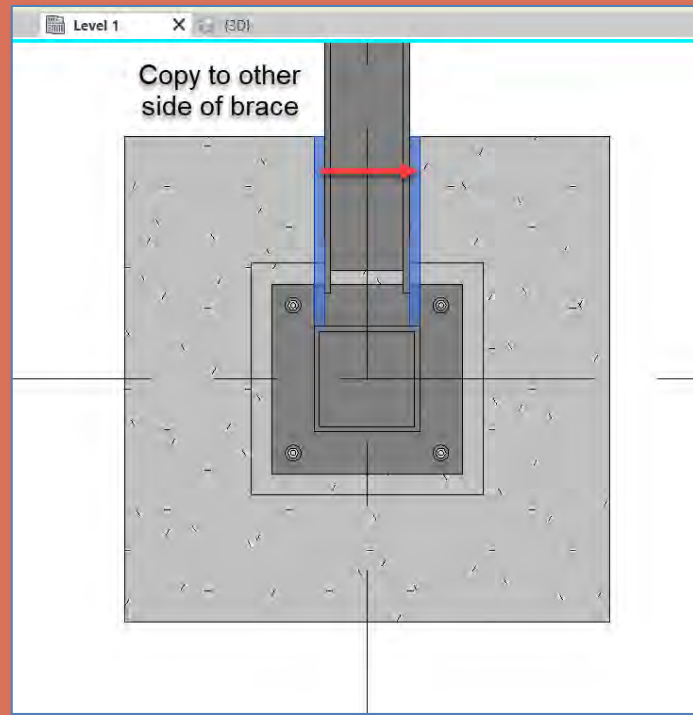
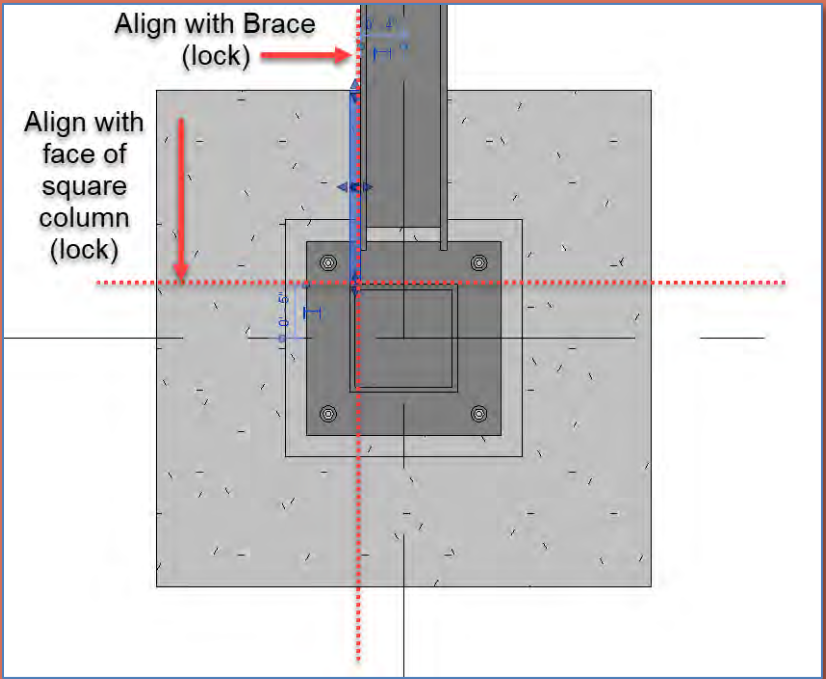
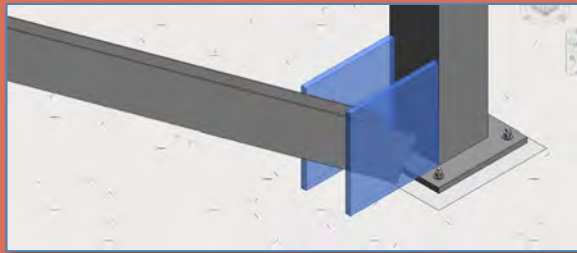

Diagonal Bracing

- Connections
- New 3D Family
 - Structural Framing – Beams & Braces
- Edit
 - W18 x 50
 - Rotate 90
 - Reference Plans & Parameters
 - Save & Name
 - Load into Project
- Position
 - Place & Align
 - Rotate from side
- New 3D Family
 - Generic
 - Save & Name
 - Load into Project
- Position
 - Place & Align
 - Copy

Copy Bracing over then up to Level 2

- Copy Endplates up to top of diagonal
- Copy diagonal brace and all four endplates up from level 1 to level 2
- Align and lock to Column and Beam

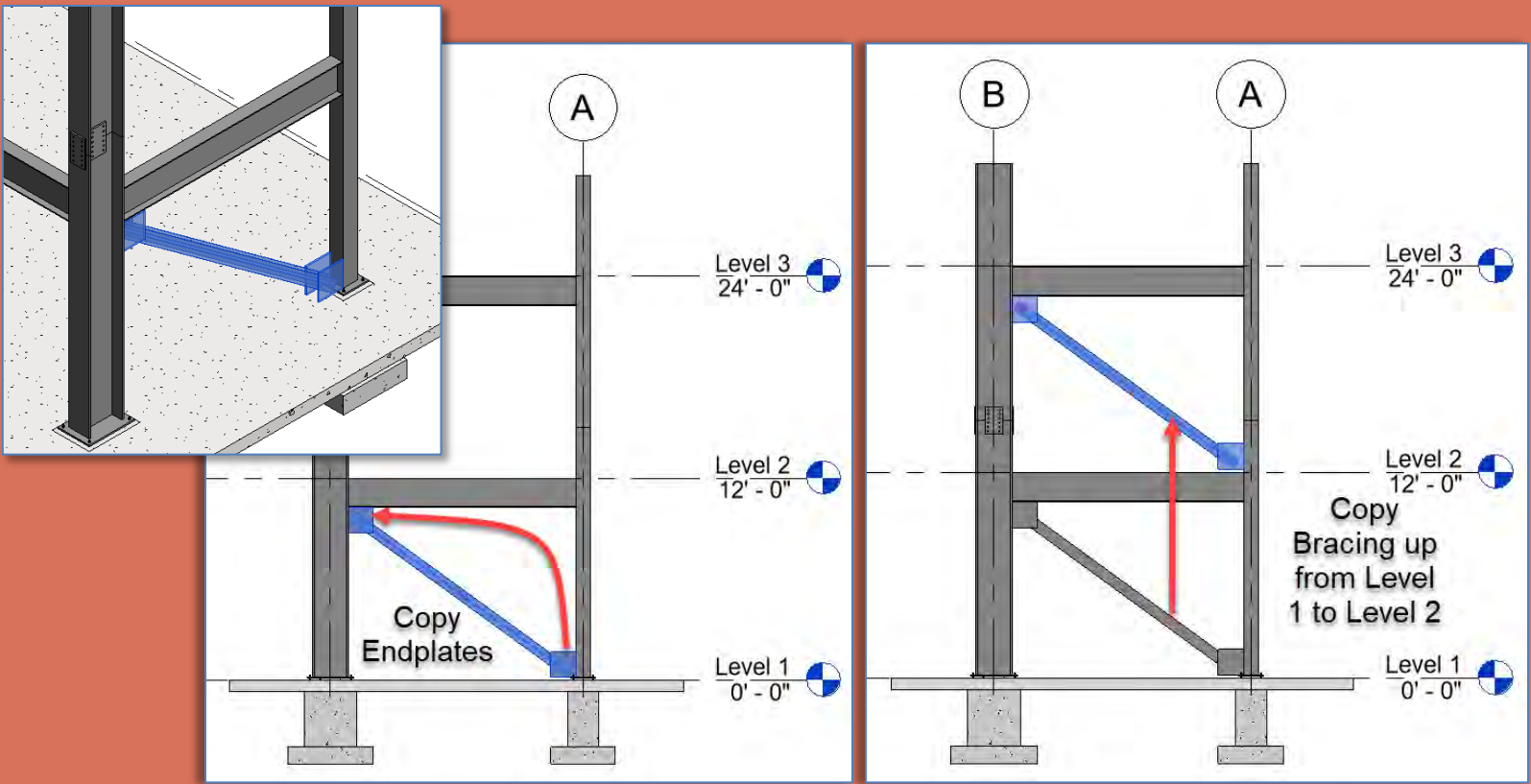

Steel Connections

Diagonal Bracing

- Connections
- New 3D Family
 - Structural Framing – Beams & Braces
- Edit
 - W18 x 50
 - Rotate 90
 - Reference Plans & Parameters
 - Save & Name
 - Load into Project
- Position
 - Place & Align
 - Rotate from side
- New 3D Family
 - Generic
 - Save & Name
 - Load into Project
- Position
 - Place & Align
 - Copy
- Isometric Views
- Sheet

Isometric Views of the Project File

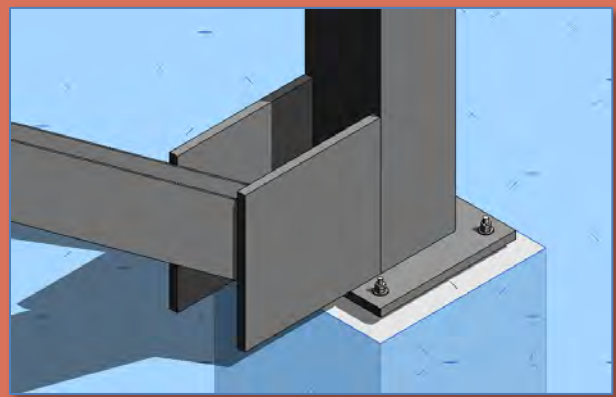
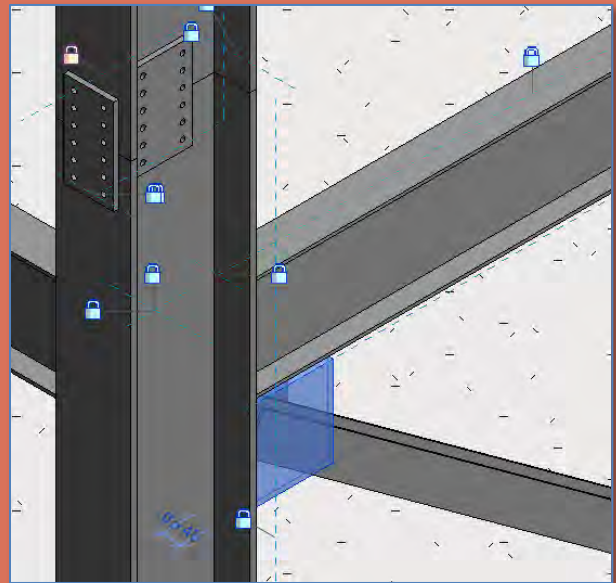
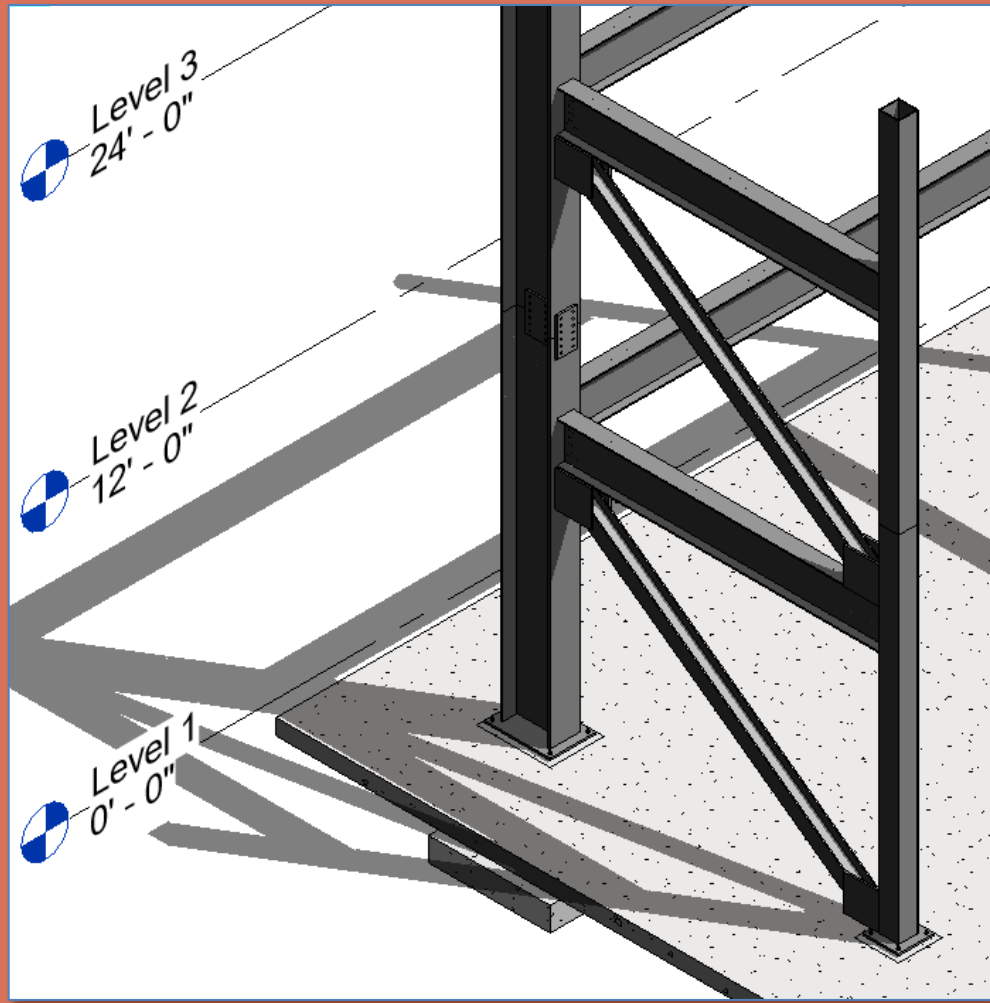

Updated Sheet - Add Additional Sheets

Diagonal Bracing

- Connections
- New 3D Family
 - Structural Framing – Beams & Braces
- Edit
 - W18 x 50
 - Rotate 90
 - Reference Plans & Parameters
 - Save & Name
 - Load into Project
- Position
 - Place & Align
 - Rotate from side
- New 3D Family
 - Generic
 - Save & Name
 - Load into Project
- Position
 - Place & Align
 - Copy
- Isometric Views
- Sheet

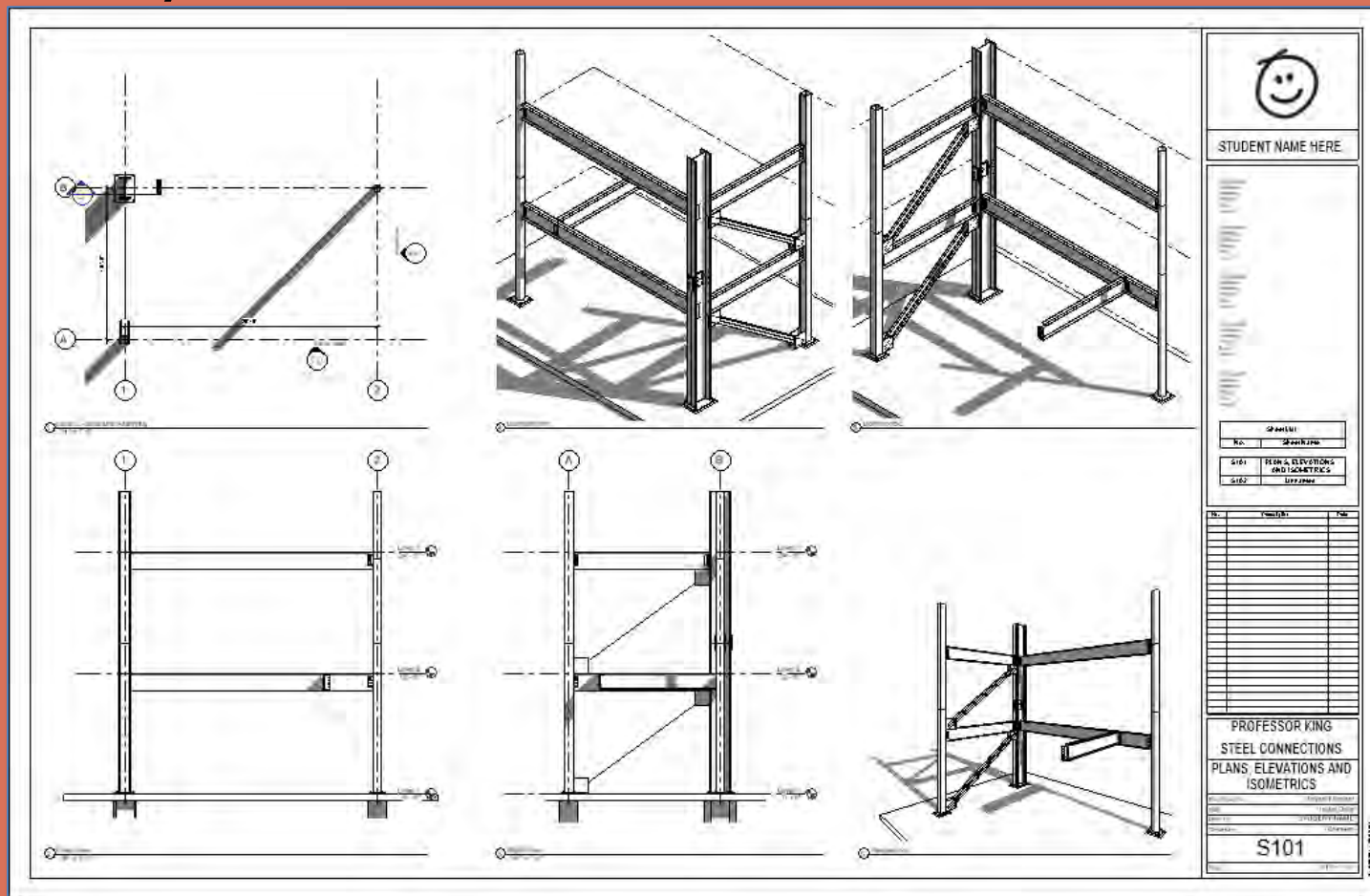

- Create additional sets of 4 views of connections & develop details
- Annotate with Notes & Leaders, Dimensions, Hatch & Detail Items



That's all Folks!