

# **How to create Isometric Drawings**

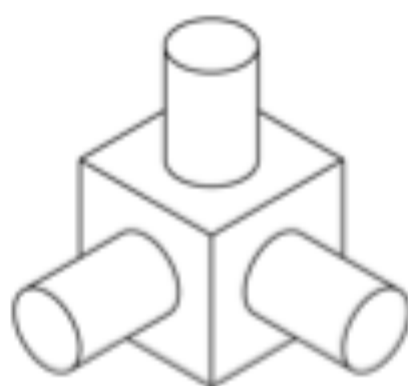

By, Mariel Perez

# Table of Content

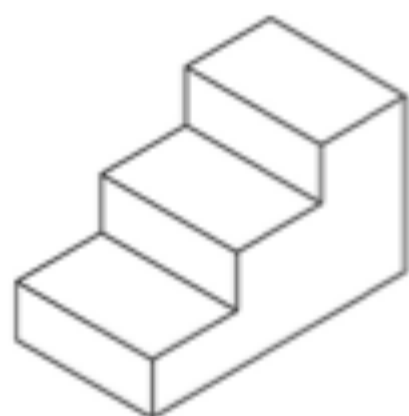

Introduction.....	1
Chapter 1- Sketching.....	
Alphabet of Lines.....	2
Construction Lines and Guidelines.....	3
Border Lines.....	3
Object Lines.....	3
Hidden Lines.....	3
Dimension Lines.....	3
Extension Lines.....	4
Centerlines.....	4
Section Lines .....	4
Phantom Lines.....	5
Sheet Layout for Sketching.....	6
Chapter 2- Drafting Equipment	
Drawing Board.....	7
T-Square.....	7
Triangles.....	7
Compass.....	8
Pencil Pointer.....	8
Erasers.....	8

Erasing Shield.....	8
Dusting Brush.....	8
Dry Cleaning Pads .....	8
Protractor.....	8
Templates.....	9
Scales.....	9
Chapter 3- How to create Isometric drawing.....	9-13
Chapter 4- Inventor 2017.....	13-19
Bibliography.....	20

## Introduction

*What is an Isometric drawing? Isometric drawings are realistic drawings; they are also called isometric projection. These drawing show three side, in all dimensional proportion, but aren't shown as a true shape with 90-degree corners. Isometric drawings allow the drawer to draw an object in three different dimensions (top side, front side, and right side). Being able to visualize and draw a three dimensional shape is a skill that a drafter, designer and engineers should master. As you can see the basic isometric drawing image below it gives a good idea of what it looks like.*

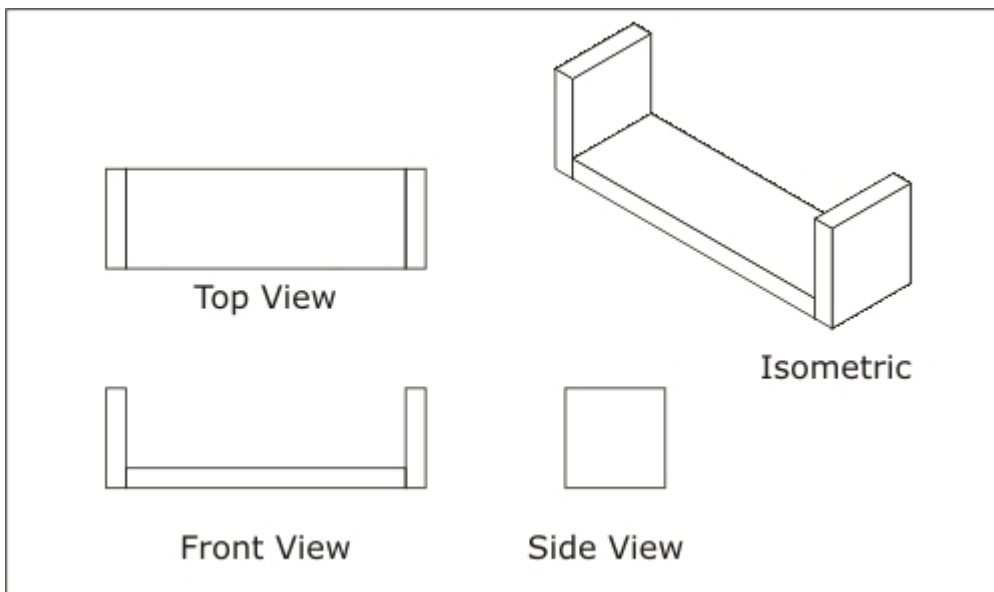

# Chapter 1- Sketching

## Alphabet of Lines

When drawing there are lines with different thickness to make a drawing. Each line in the **Alphabet of Lines** has a unique meaning. The difference between the lines makes it easier to read the drawings. Certain lines are made with straight solid lines and others are made with a specific length of dashes. These lines are all vary in length also thickness.

Alphabet of Lines Color Codes			
Line	Weight	Color	Appearance
Construction	Very thin .012"	Blue	
Guideline	Very thin .012"	Blue	
Border	Very thick .047"	Black	
Object	Thick .024"	Black	
Hidden	Thin .014"	Black	
Dimension	Thin .014"	Red	
Extension	Thin .014"	Red	
Centerline	Thin .014"	Green	
Cutting-plane	Thick .024"	Black	
Section	Thin .014"	Black	
Phantom	Thin .014"	Black	

# ALPHABET OF LINES

To read a drawing, you must know the use of lines. In this section, I will briefly discuss each of these drawing elements. The "Alphabet of Lines" is a list of line symbols that are used on technical drawings to represent the shape and describe the size of an object. Drawing or sketching is a universal language used to communicate all necessary information to the individual who will assemble an object. Each of the following lines are drawn differently, this consist of how their thickness or darkness vary for contrast as well as according to the importance of the line. The list below gives the name of the line; explains how the line is used; indicates the appropriate thickness or darkness; and provides the recommended pencil weight for drawing the line.

---

## Construction Lines and Guidelines

Construction lines and guidelines are temporary line work that are used as a reference when creating and drawing objects or lines. Construction lines are usually straight lines that are extended. Theses lines are drawn softy, they will be gray lines instead of black.

---

## Extension Lines

Extension lines are drawn as a solid straight line. They represent the beginning and the end points of a linear distance. The line begin  $1/16'$  (.06') away from the edge.

---

## Border Lines

Borderlines are the darkest lines that are used in sketching. The lines are first drawn as a light construction line for a guide then the line is drawn over again to make the lines darker and thicker lines.

---

## Object Lines

Object lines, which are also called visible, object line. These lines show the visible edges and intersection of an object.

---

### Hidden Lines

Hidden lines are drawn with short dashed lines, they are used to show hidden parts of an objects or objects below or behind another object. Hidden lines are not visible from the viewers to see, this is why it is called an invisible object line. The hidden lines are drawn with are series of dashes ( $1/8'$ ) and with spaces ( $1/16'$ ) between the dashes.

---

### Phantom Lines

Phantom lines are lines with a series of dashes and very short dashes and they are used to show movement.

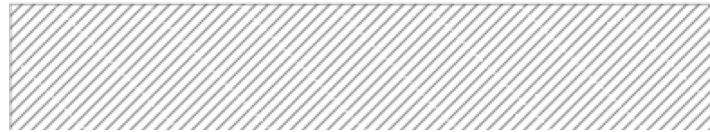

### Section Lines

These lines are parallel that are inclines at 45 degree the space between each line is  $1/8''$  (.125"). Section lines are used to draw features that inside of an object. They are also used to indication classification of materials.

---

### Cutting Plane Lines

There are two ways to draw cutting plane lines as shown above. The first line consists of a long dash ( $3/4''$  to  $1-1/2''$  or  $.75''$  to  $150''$ ) with smaller lines ( $1/8''$  or  $.125''$ ) with space in between of  $1/16'$  (.06'). The second line consist of a series of lines of  $1/4'$  (.25') with space in between them of  $1/16'$  (.06'). Cutting plane lines show where an object has been cut to show features that are interior features.

---

### Centerlines

Centerlines are used to indicate the center of round objects. There are three types of centerlines, which are primary centerlines, secondary centerlines, and symmetry centerlines.

---

### Dimension Lines

Dimension lines are used to label a particular dimension; they provide a clear and complete description of an object.

## Sheet Layout for Sketching

Every drawing sheet has a particular layout to follow. A construction line will be drawn at  $\frac{1}{2}$ ' around the edge of the paper. The  $\frac{1}{8}$  that is shown on the figure 1 shows the measurement that are to be drawn after the borders are creates where the information will be written in.

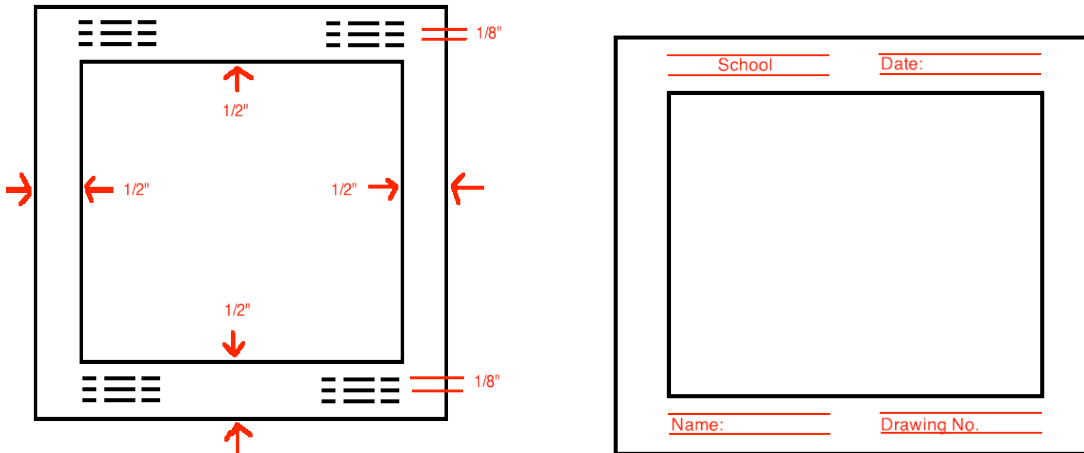

I created these images. These images will be placed in chapter 2 to describe a sheet is layout for sketching. As shown you cans see that the borders have to be  $\frac{1}{2}$ , and the lines where your information goes has to be  $\frac{1}{8}$  each line.

I created this image. This will be in chapter 2 as well. It shows the format of how your drafting sheet should be. As the first images give you the measurements of the space in between the lines. This illustrates where your information should go.

## Chapter 2- Drafting Equipment

In drafting there are certain equipment that are need when drawing isometric drawing by hand. This following chapter will go over what equipment's are needed. In the image below you can see a drafting board (the drafting board come in different sizes 8.5 x 11, 11 x 17, 17 x 22) the dimensions of the sizes are in inches, T-square, the

*different types/size of triangle that are used, scale, drafting tape, compass, eraser (best if white erasers are used since it will not leave any color behind when you erased a mistake), dividers, pencil pointer does actually what it is called it makes pencils sharp, dusting brush, protractor, pencil, erasing shield.*

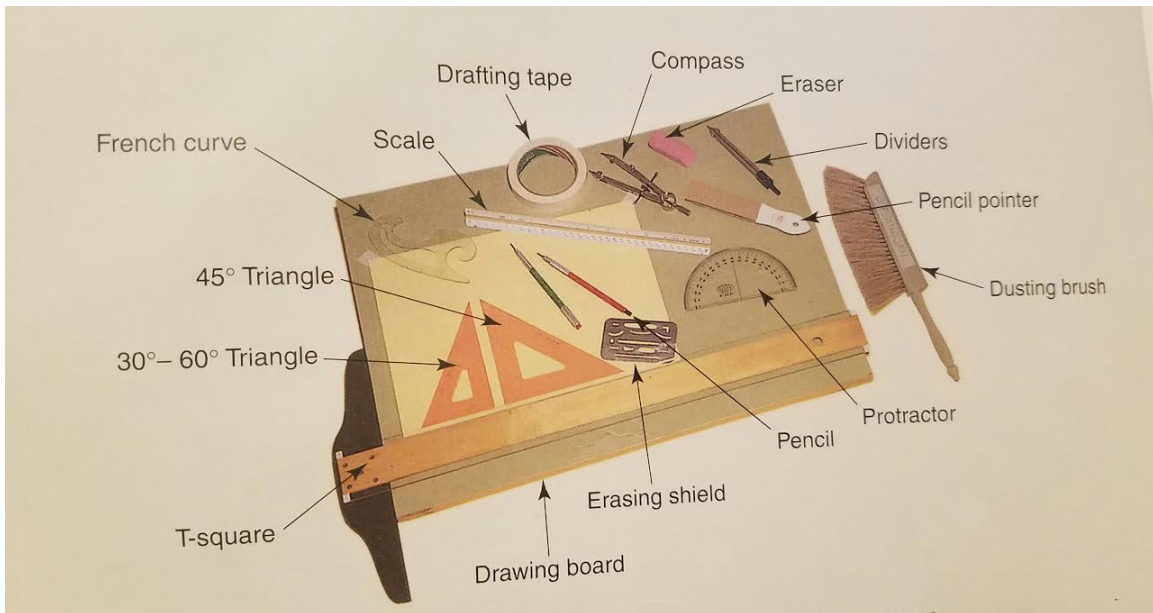

### **T-Square**

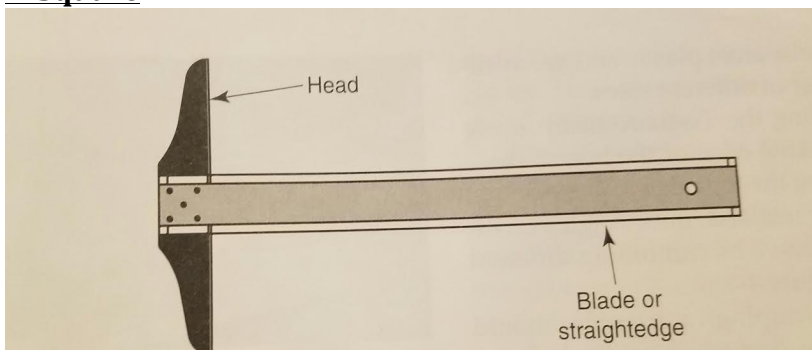

A T-square is a drawing instrument that is used as a guide for drawing horizontal or vertical lines on a drafting table or a drawing board. As you can see has two parts to it (the head and the blade). The head is what lays on the drawing board and the blade is what is used to draw the lines.

### **Triangles**



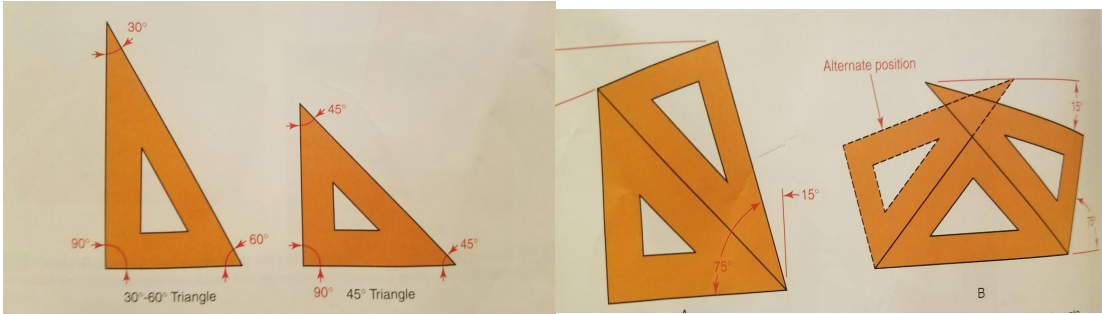

These triangles come in different sizes. There are two different triangles one is a 30°-60° triangle and the one next to it is a 45°-90° triangle. They are used to create angles, vertical and inclined lines. When the triangles are joined together as the picture on the right shows a 75° angle is formed and a 15° angle.

### Compass

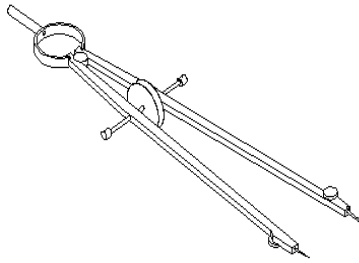

Compasses are used to draw circles as your desire size and to make arcs.

### Scales

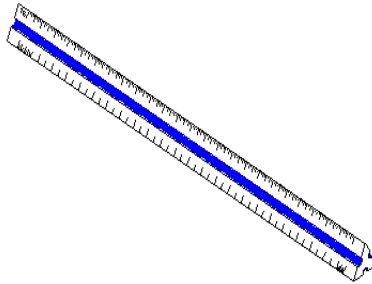

Scales are used to layout measurement at a reduced or enlarged size.

### Drafting Brush

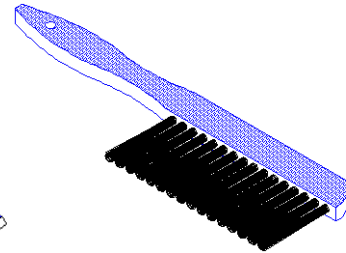

Drafting brushes are used to remove eraser dust form the drawing so your drawing won't smudge since many time our hands are sweaty, it can mess up your drawings.

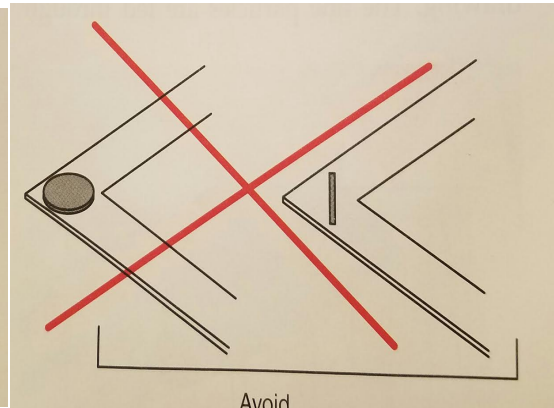
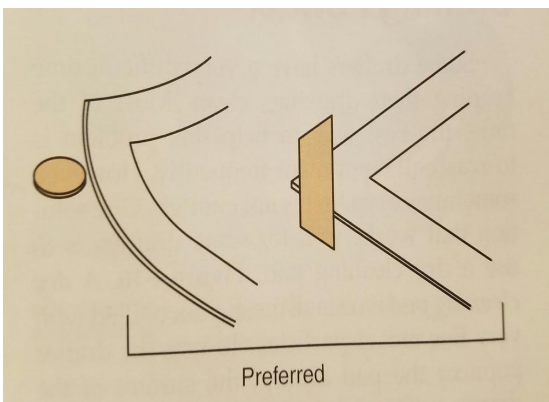

*This is showing the proper way to tape your paper, if it isn't properly taped when trying to remove your paper from the drafting board you paper might rip.*

### *Chapter 3- How to create an Isometric drawing*

*The image below will be the image that will be the final product of our drawing. This is an isometric drawing as mentioned before Isometric drawings are 3D drawings. They show three sides, all in dimensional proportion, but none are shown as a true shape with 90-degree corners.*

*It is a method for visually representing three-dimensional objects in two dimensions in technical and engineering drawings. (What is an isometric drawing? (n.d.). Retrieved May 14, 2017, from [http://metal.brightcookie.com/2\\_draw/draw\\_t3/htm/draw3\\_2\\_2.htm](http://metal.brightcookie.com/2_draw/draw_t3/htm/draw3_2_2.htm))*

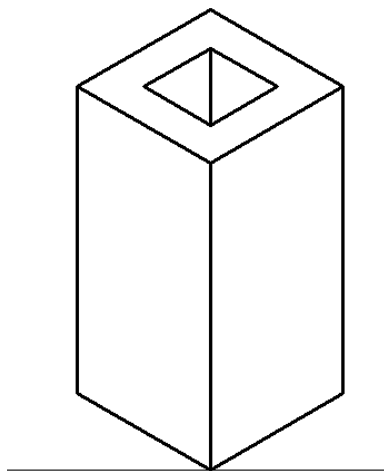

*Step 1: You Start by drawing a straight line*

---

*Step 2: You will draw a straight line upwards using your protractor at 90 degrees. The line will be drawn dimly*

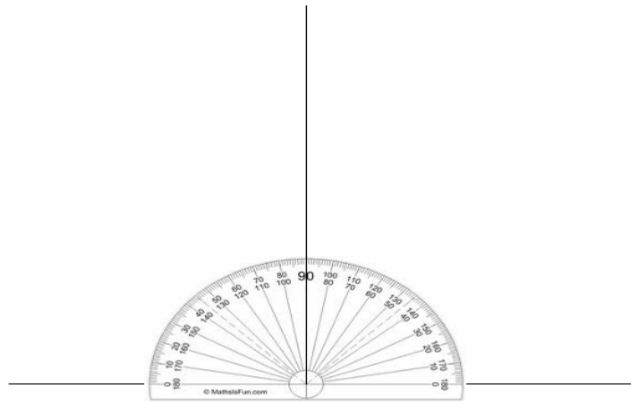

*Step 3: Two lines will be drawn at 30 degrees each, once again your lines will be drawn dimly because they are guidelines.*

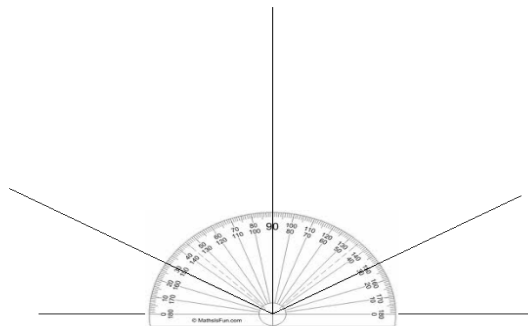

*Step 4: After you will measure 100mm along the horizontal line and make a small cross*

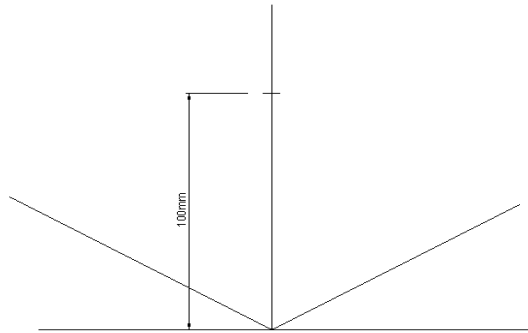

*Step 5: From the cross line you made, using your protractor you will draw 2 more lines at 30 degrees.*

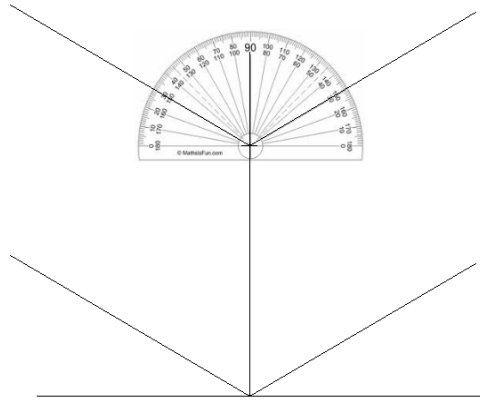

*Step 6: Measure 80mm as shown and make two straight lines*

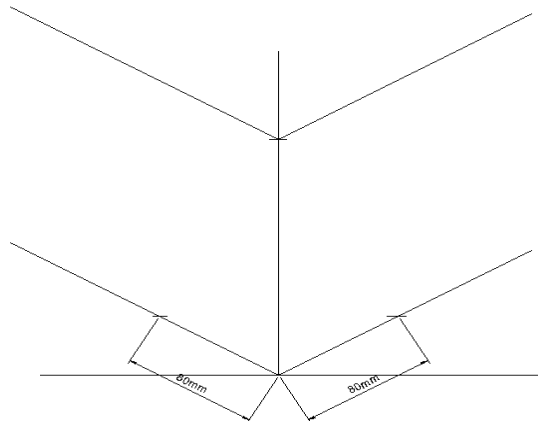

*Step 7: Making sure that your lines are 90 degrees, you will draw two lines straight up*

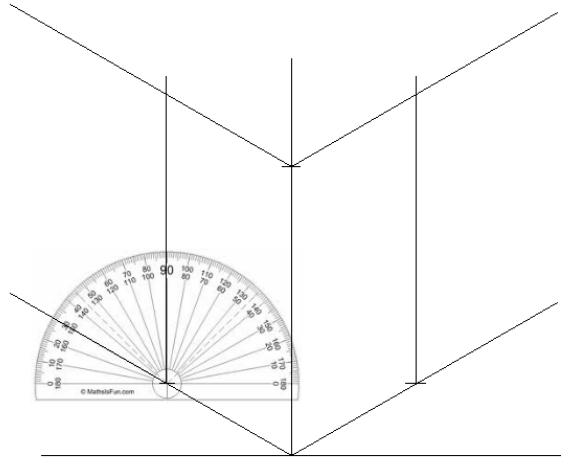

*Step 8: Place your protractor on the top left corner and create a 30-degree line as it shows in the image below.*

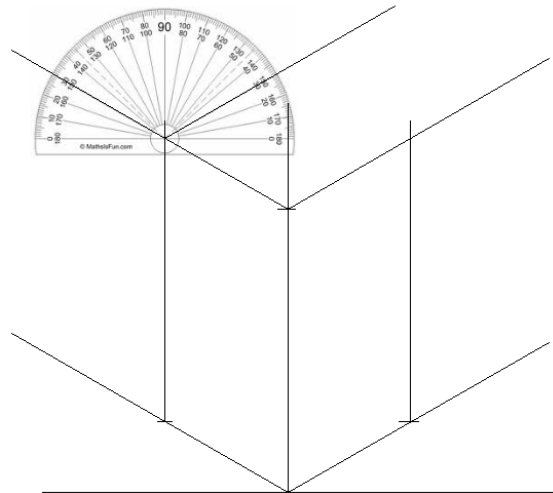

*Step 9: Complete the cube. Lastly draw over your faint lines and make them look bold.*

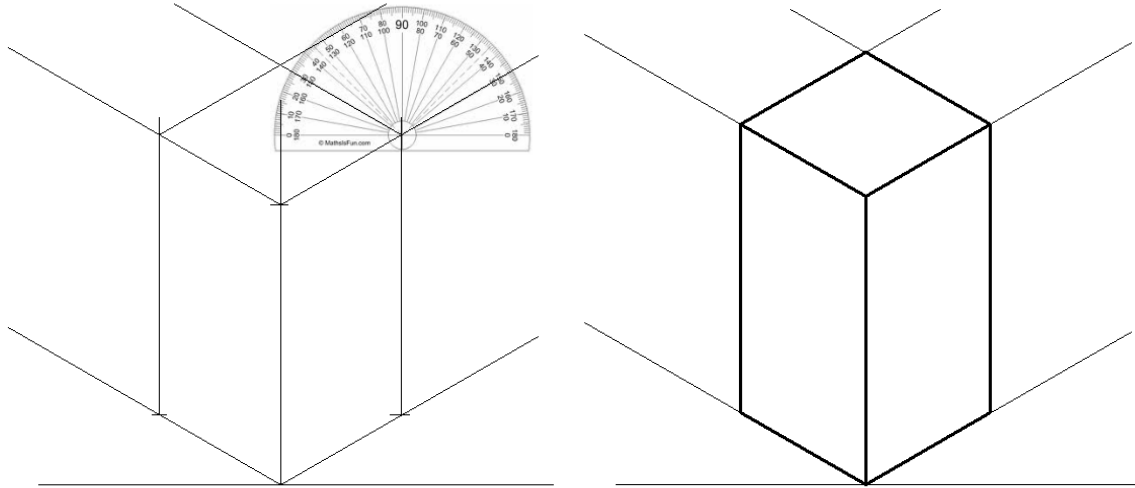

## Chapter4- Creating Isometric Drawing using Inventor 2017

*What is Inventor Autodesk Inventor, is a computer-aided design application for creating 3D digital prototypes used in the design, visualization and simulation of products. 2017?*

*You will open up Inventor and click new, and create 2D sketch.*

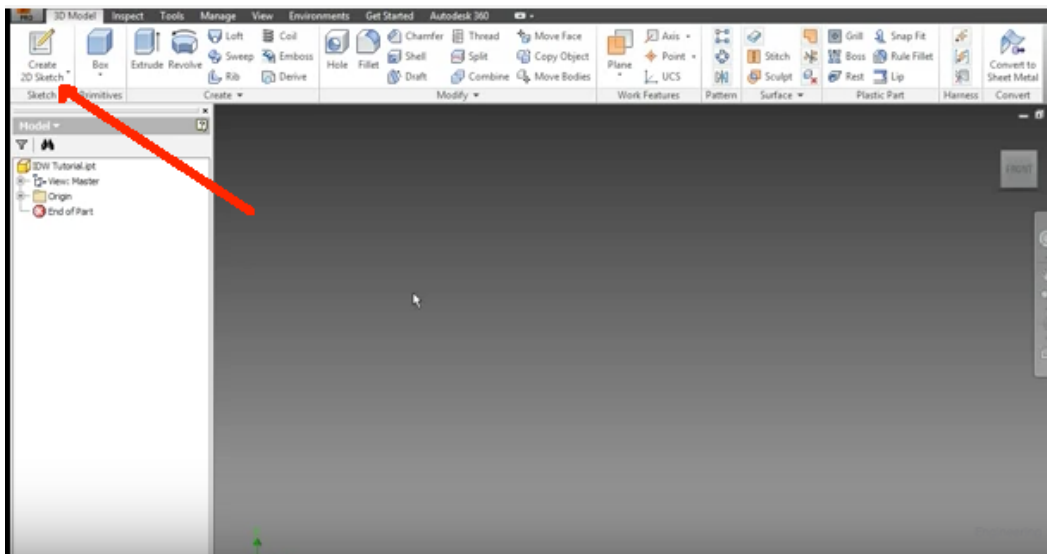

Once 2D sketch is sketched this image will appear on the screen, as I pointed out on the photo using a red arrow that is the XY plane and that will be the plane where we will be creating our drawing. Once your click the XY plane you can begin your drawing.

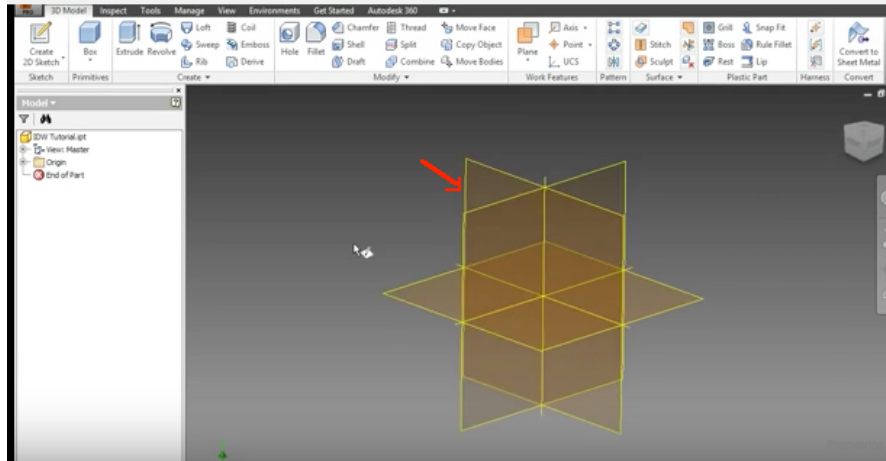

Your screen will show grid line and you will create your drawing now. Click rectangle so the arrow shows.

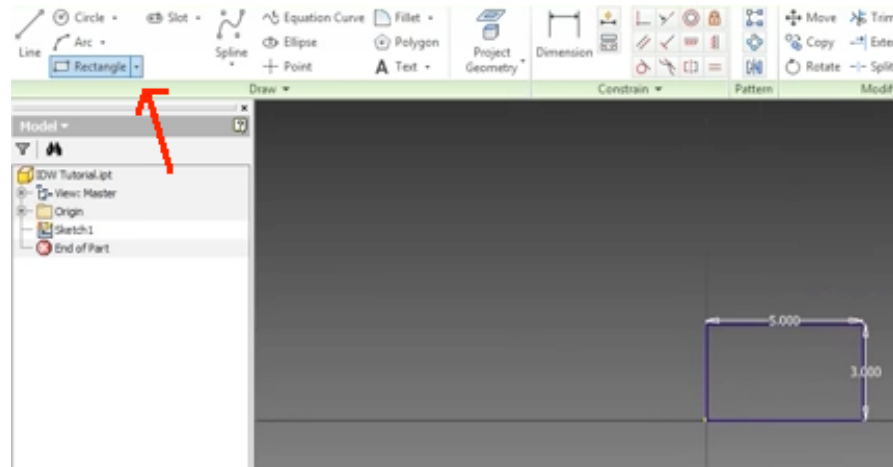

After this is done you will click where it says 3D model and click where it says extrude (extrude makes your drawing 3d). Once the extrude box shows up you can adjust the size of how long you want your extrusion to be and the distance of the extrusion right now show 1, you will change the distance to 2.5. After you have changed the distance you will change the direction the extrusion will be made and you click the one shown below.

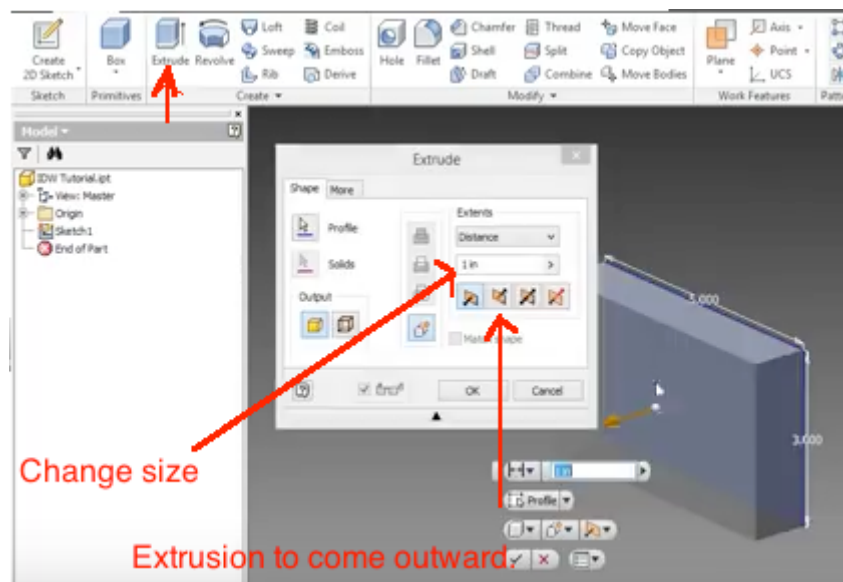

You will create a new sketch on the plane that is highlighted in red and you will click line and create the drawing on the using line and create a downward triangle. After that click where it says dimension to measure the space in between the two points that are shown on the image below.



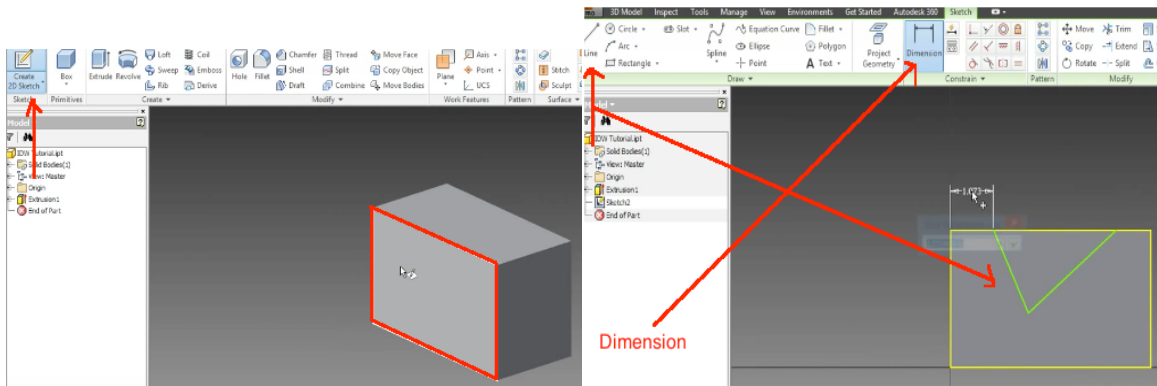

*After the triangle has the dimension as the one below, you will do the same process to the other side of the rectangle. But instead of the dimension being 1.00 the dimension will be changed to 1.50.*

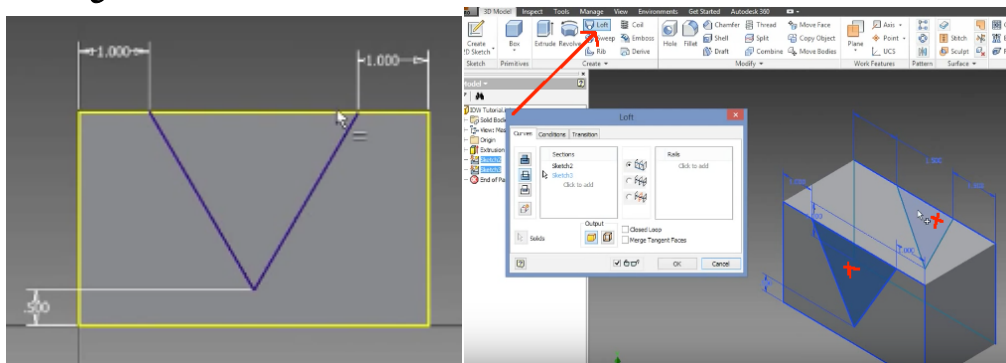

*Once the dimension has been change to 1.50 select loft and select the points where the x's are showing, this will cut the shape of the triangle. It will look like the image below. You will create a drawing now. When creating a drawing like mentioned in chapter 1, this is the layout sheet here the drawing you creating will be places to show different views (top view, side, view, and the right view)*

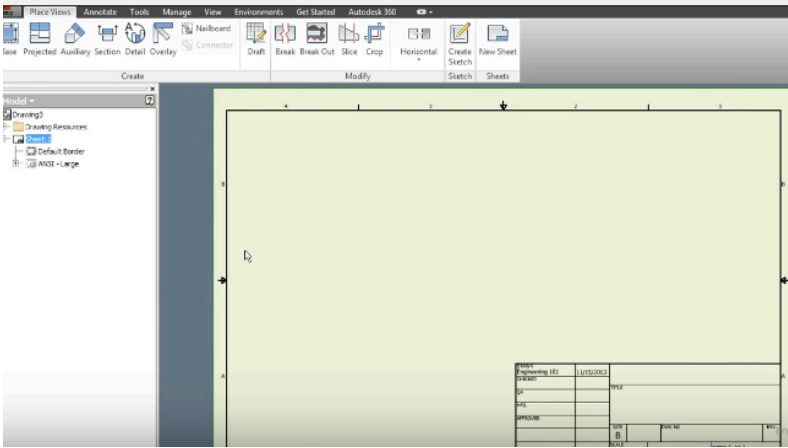
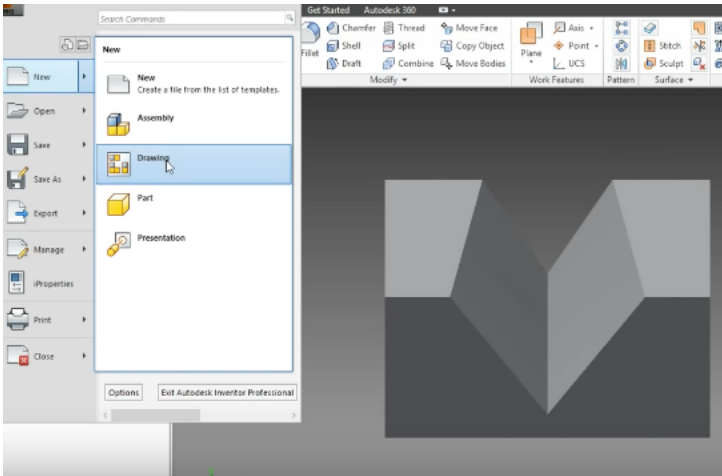

*This is what will see once you select drawing. This is the sheet where your drawing will go*

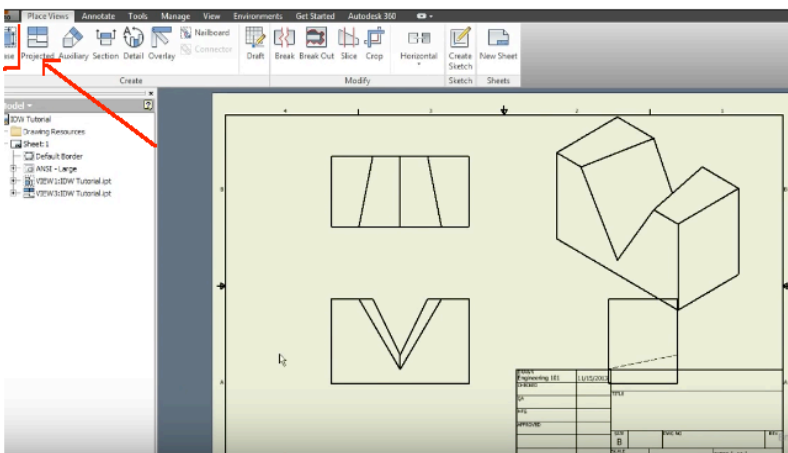

*After the sheet is open you will select the square red box that says base and then project. As you can see when once project is selected you are able to see the front view, side view, top view, and corner view.*

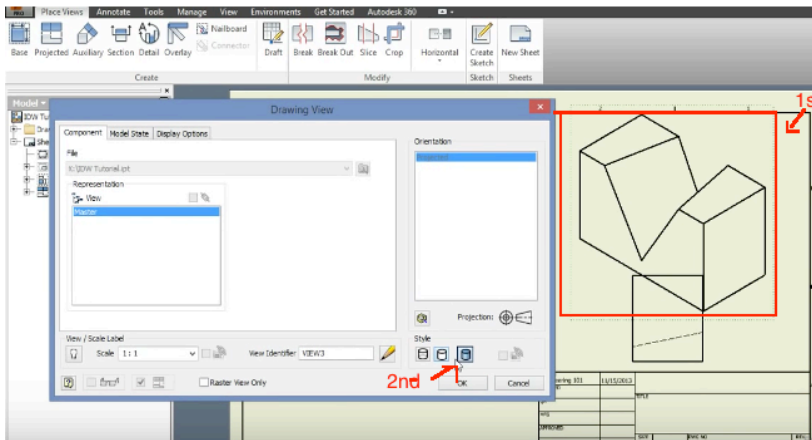

The red box that you see is the drawing you will select and the bottom that say 2<sup>nd</sup> and this will change the way the item is present.

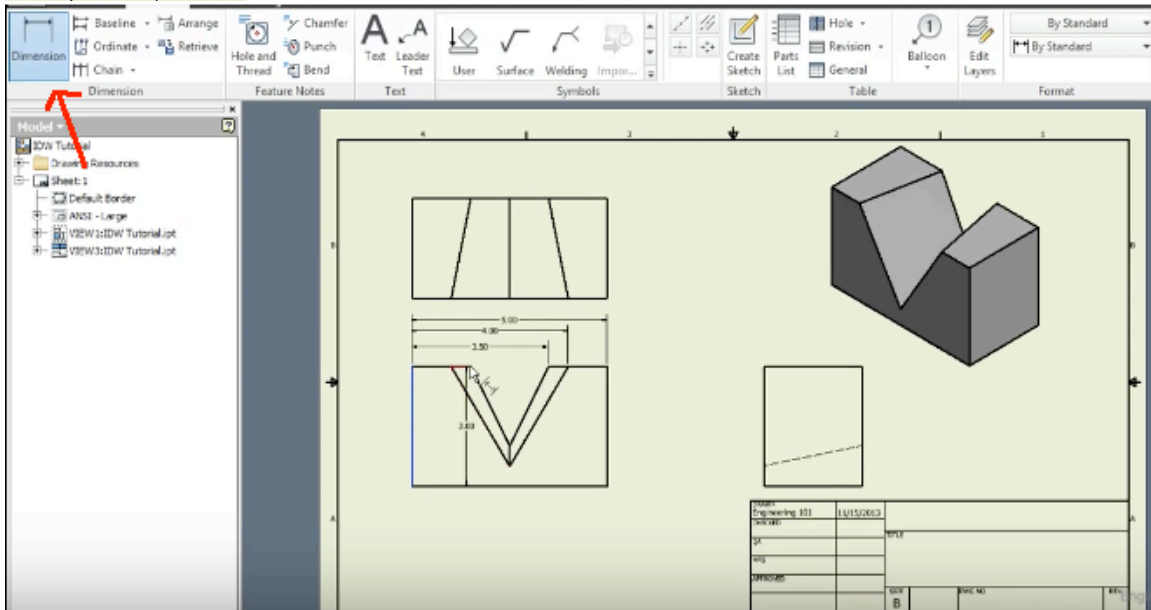
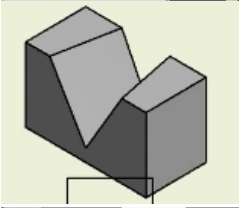

Select annotate and click dimension to show your dimension of the sheet you will do this for every drawing.

As shown isometric drawing can be drawn either by hand or using inventor. Both are straightforward after you understand what you are doing.

## Bibliography

1. *Technical Drawing*. (n.d.). Retrieved May 19, 2017, from <https://www.pinterest.com/cholmes1821/technical-drawing/>
2. *Drawing Size Reference Table, Architectural and Engineering Drawing Sizes*. (n.d.). Retrieved May 19, 2017, from <http://www.engineersupply.com/Drawing-Size-Reference-Table.aspx>
3. *(Alphabet of lines)*. (n.d.). Retrieved May 16, 2017, from <http://www2.wisd.net/archive/industrialtech/DRAFTING/alphabetlines.htm>
4. *What is an isometric drawing?* (n.d.). Retrieved May 14, 2017, from [http://metal.brightcookie.com/2\\_draw/draw\\_t3/htm/draw3\\_2\\_2.htm](http://metal.brightcookie.com/2_draw/draw_t3/htm/draw3_2_2.htm)
5. *Mathematics* (n.d) Retrieve May 10, 2017 from [https://www.123rf.com/stockphoto/instrument\\_of\\_mathematics.html](https://www.123rf.com/stockphoto/instrument_of_mathematics.html)
6. *Isometric Drawing*. (n.d) Retrieved May 06, 2017, from <http://www.businessdictionary.com/definition/isometric-drawing.html>
7. *Inventor Tutorial with Isometric Sketches – Intermediate part 4b of 20 multiviews* (n.d). Retrieved May 14, 2017, from <https://www.youtube.com/watch?v=xvGCF8ks5Mk>