

Spring 2011

---

**Phase 3 Stage 2: ADDING THE STAIRS : ATRIUM & 2 EGRESS STAIRS**

---

**Overview:** We will add three stairs to the lab building. One will connect an extension of the second level slab to the atrium space and two additional internal egress stairs will run from the first level up to the roof.

**Create Atrium Stair:** Start by creating the Atrium Stair

**Extend Floor Slab:** Working on **Level-2** extend the floor slab to extend into the atrium as shown below. To make it easier to work hide the categories for walls and windows.

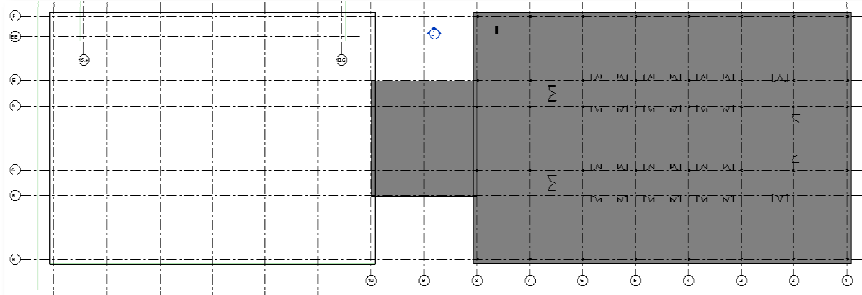

**Slab & Guidelines:** Offset three model guidelines 12" to the outside of grid lines **D, B & 10**. On the **Home** tab select **Floor > Rectangle** and draw a floor slab snapping to the guides.

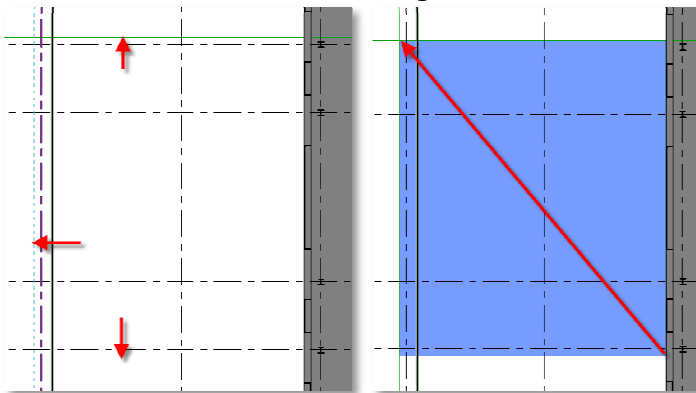

**Stair Guidelines:** Start from the **midpoint and edge of the second floor slab** and draw a line **horizontally** into the atrium **30' long**. **Offset** this line **10' in each direction**.

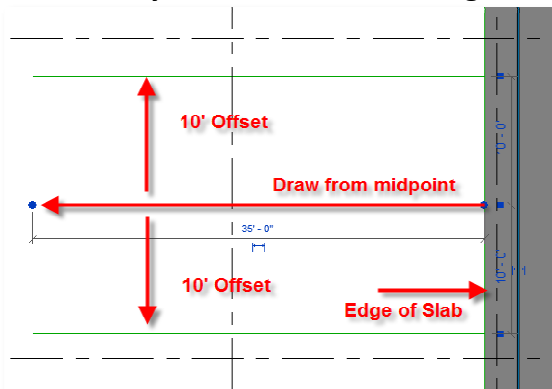

Spring 2011

**Draw the Stair:** On the home tab under the "circulation group" select **Stair**.

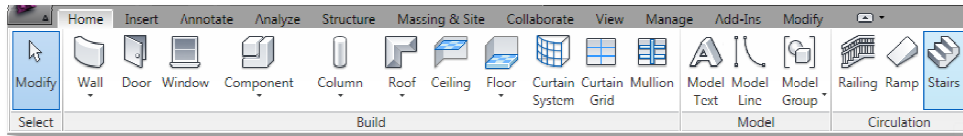

**Stair Properties**

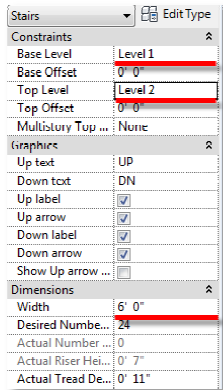

ne

*Level in this  
mines the  
uired*

**Draw the stair:** 12 risers across to the left

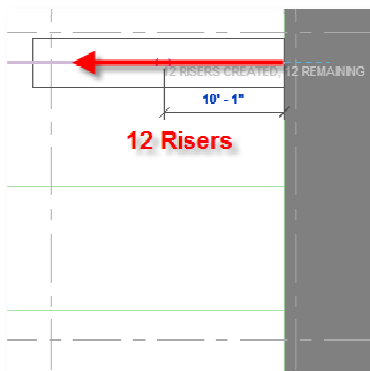

then down for the landing.

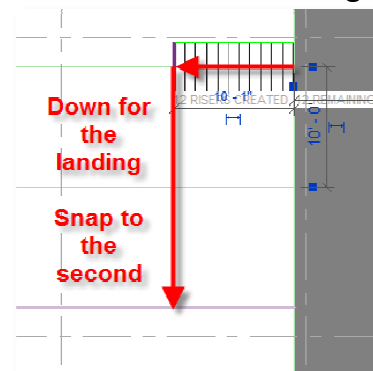

then back across for 12 more risers

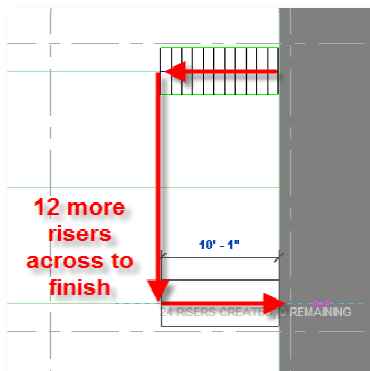

**the completed stair**

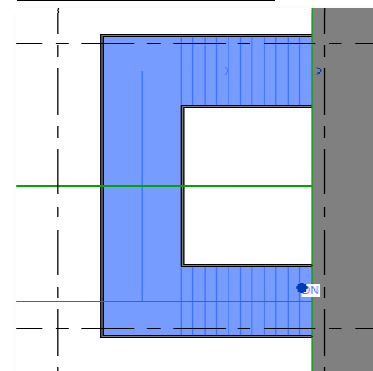

**Finish the Stair:** Exit to Finish the Sketch

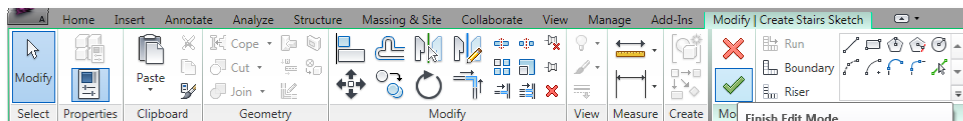

Spring 2011

**Edit the Stair:** Select the Stair and select "Edit Path".

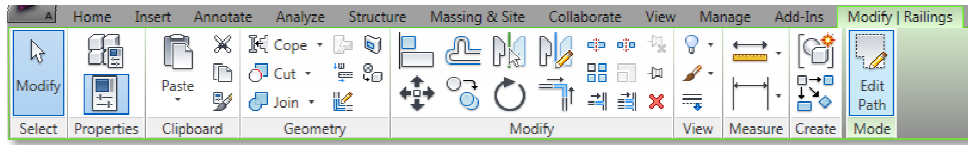

Draw an Arc using "Start-End-Radius"

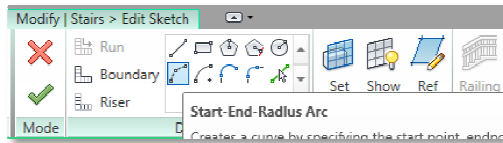

Select the **three points** as shown and then modify the **Radius to 20'-0"**

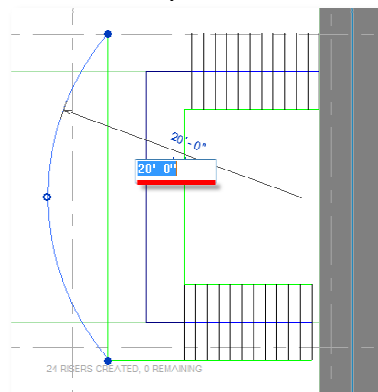
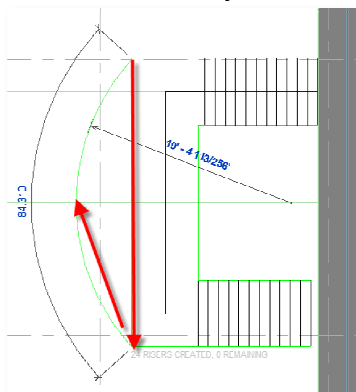

Delete the original **Straight Line**

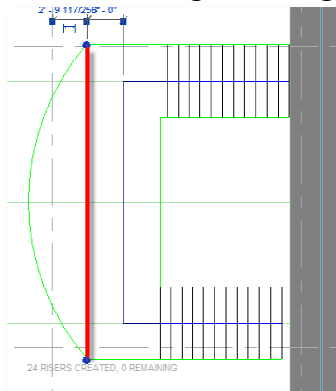

Finish the Sketch to see the updated stair

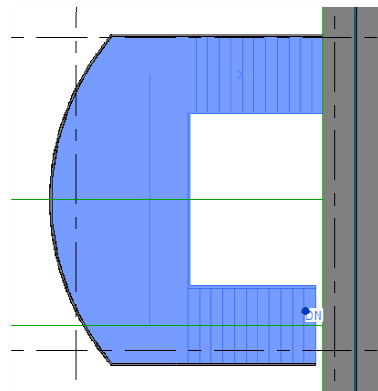

**Before**

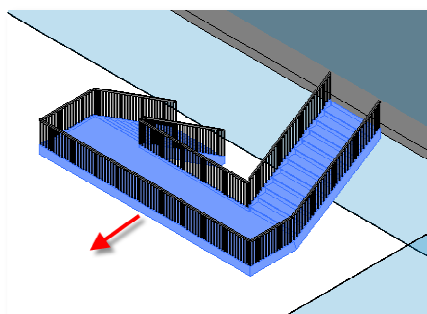

**and After images of the stair**

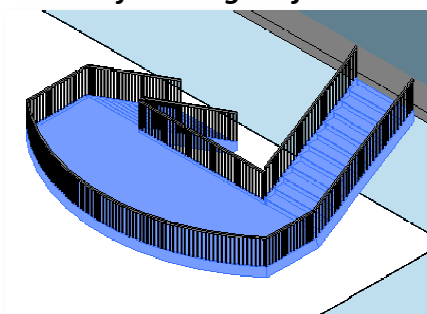

Spring 2011

**Create Egress Stair: Create the first of two egress stairs**

**Create a Shaft:** Create a shaft that penetrates the floor slabs to prepare for the stair. Working on **Level-2**, offset the two grid lines **7** and **A** at **12"** to allow for clearance from the beams. Offset these new lines **8'-9"** and **15'-6"** to create guidelines for the shaft.

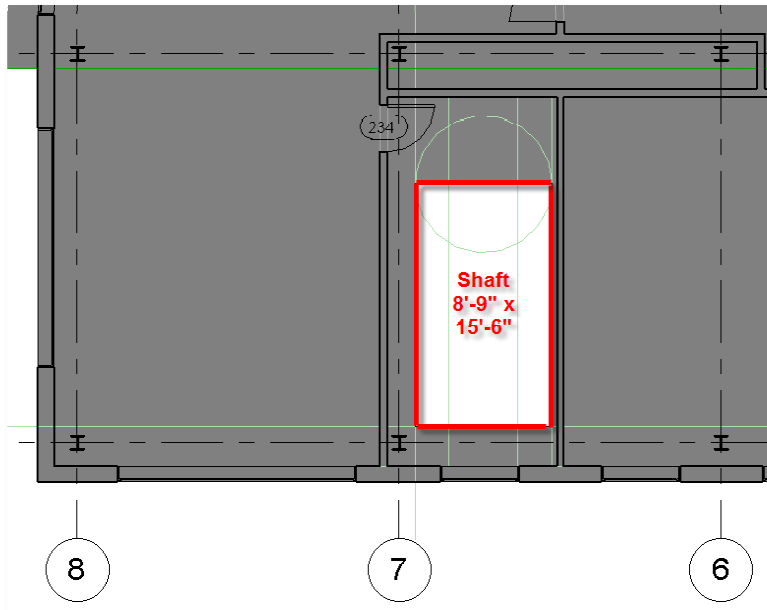

**Set Properties:** On the **Home** Tab under "**Openings**" select **Shaft**.

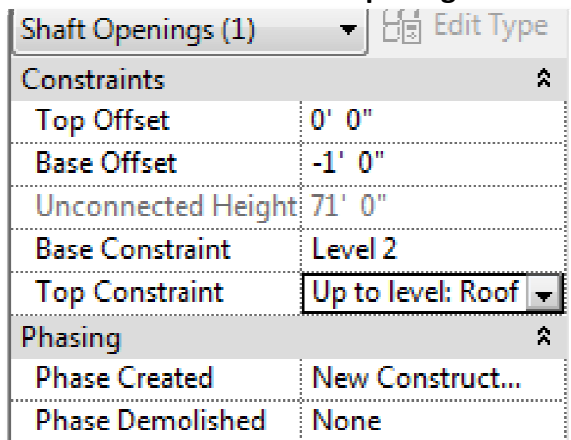

Setting as follows:

- Top Offset = -1'-0"
- Base Constraint = Level 2
- Top Constraint = Up to Roof

**Draw Rectangle:** Draw a rectangle to match the guidelines and then **exit to save** the sketch.

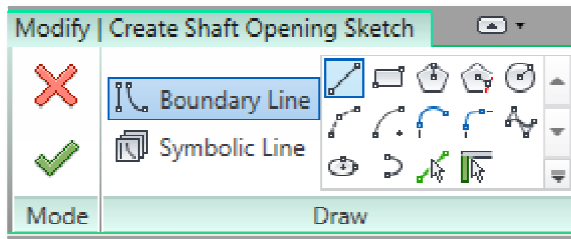

Spring 2011

**Stair Guidelines:** For a 4' wide stair create guidelines offset 26" from each edge of the shaft. Draw a circle from midpoint to end and ***be certain it does not intersect the door.***

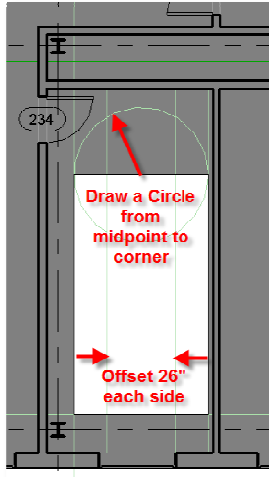

**Set the Stair Properties**

Base Level = Level 1  
Top Level = Level 2  
Multistory Top = Roof  
Width = 4'-0"

**Note:**  
By setting Multistory to Roof the stair repeats until it reaches the roof

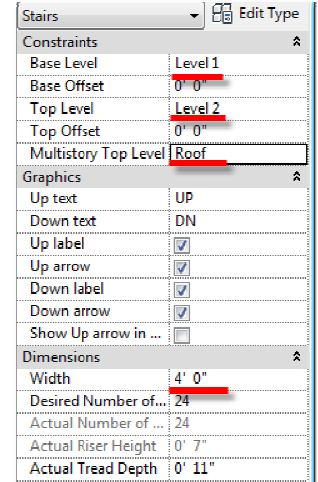

**Draw Stair:** Create 12 Risers down across for landing and 12 risers back up

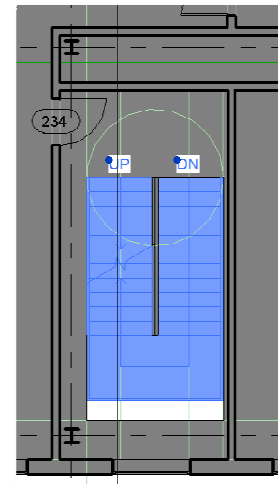
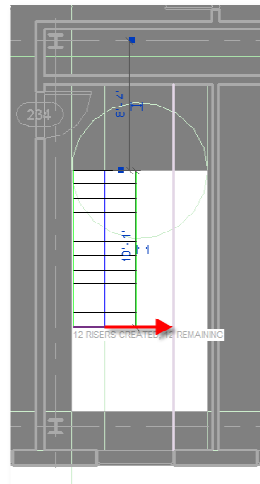
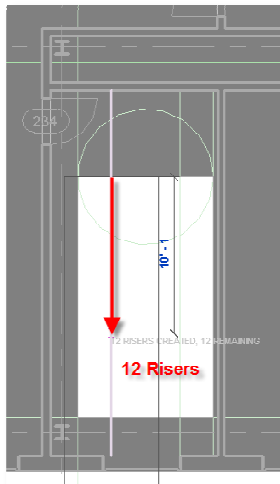

**Finish Stair:** Exit to Save the Sketch and finish the stair.

**Section Check:** Next create a section to check the stair. View > Section

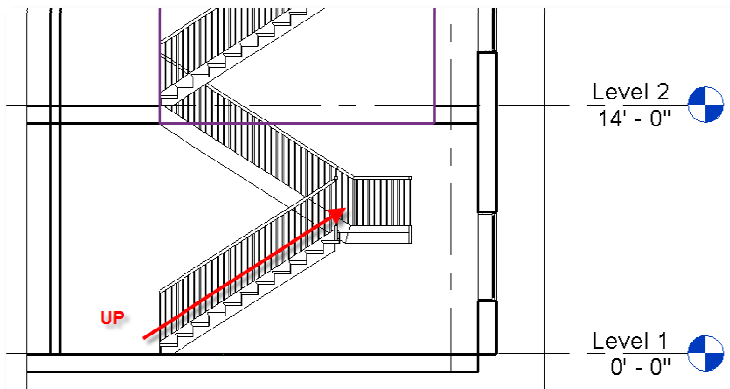

Spring 2011

**Second Egress Stair: Create the second egress stair**

**Overview:** As with the first egress stair the second will require a shaft opening. In this instance however there is limited space available to create a workable stair and we will have to look into several design options to determine a solution.

**Setup Guidelines:** The space available to us for the stair is approximately **19'-2" x 7'-6"** leaving room for a **42" wide stair**. Working from **Level-2**, begin by **creating guidelines 23"** from the face of the two walls and **12"** from **grid line 1** to allow for clearance from the beam. Offset this line again a distance of **11'-0"** and then draw a circle with a radius of **3'-9"** (**diameter 7'-6"**) and be certain it clears the door swing.

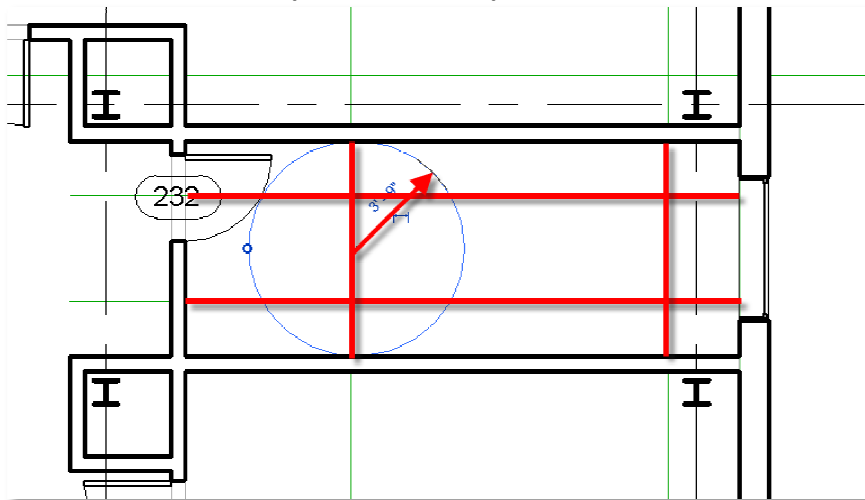

**Create the Shaft:** Create a shaft **11'-0" x 7'-6"** by snapping to the guides.  
**Home > Openings > Shaft > Rectangle**

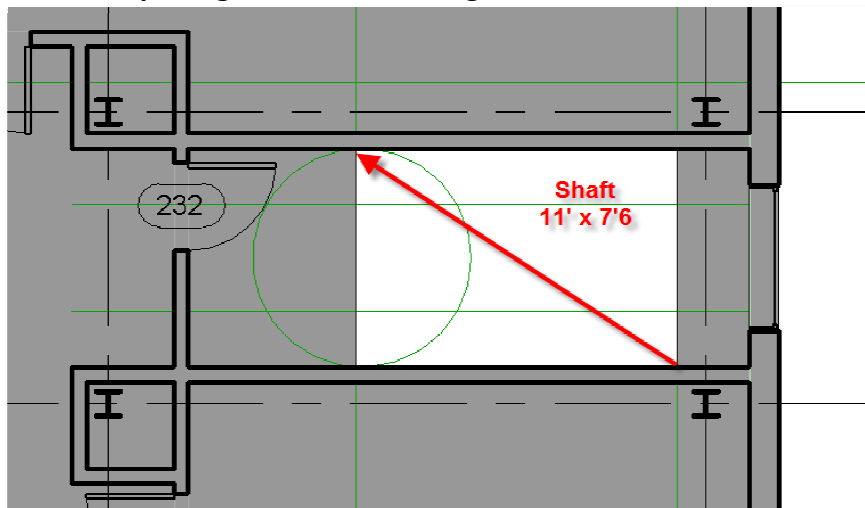

**Shaft Properties:** **Base Offset = -1'-0"** (accounts for the thickness of the slab)  
**Base Constraint = Level 2** (bottom of the shaft)  
**Top Constraint = Up to Level Roof** (top of the shaft)

Spring 2011

**Draw the Stair:**

**Home > Stairs > Run > Draw line**

Across to the **right** for **12 Risers** snapping to the first guideline

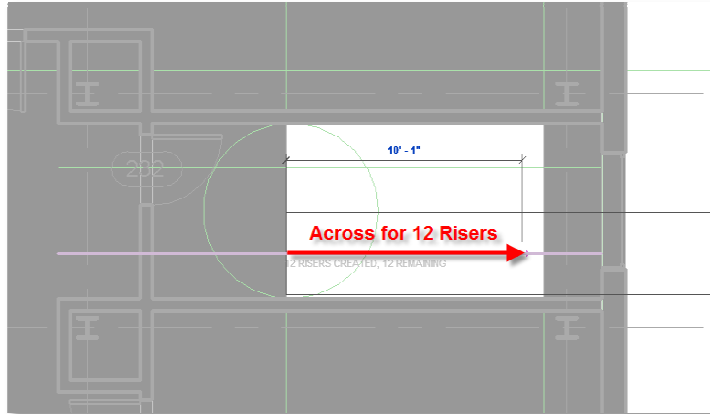

**Up** to the **second offset guideline** for the **landing**

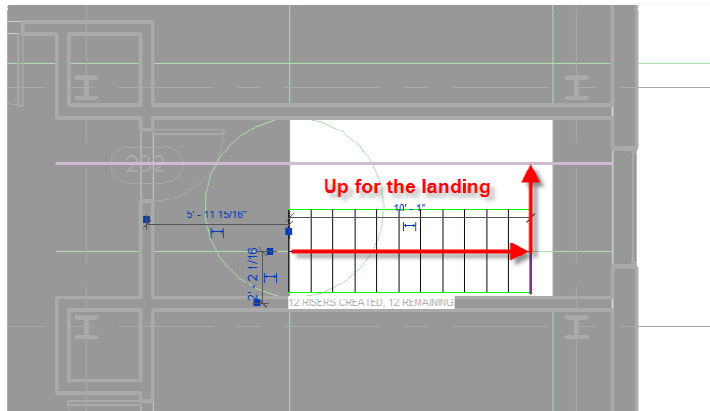

**Back** to the left along the guideline for the **remaining 12 risers**

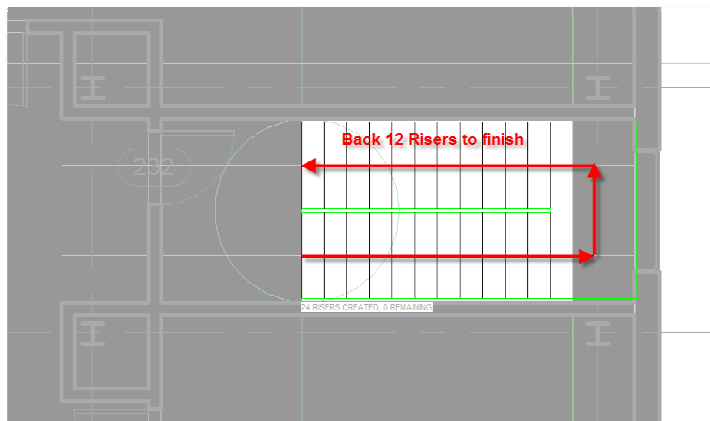

**Stair Properties:**

<b>Base Level = Level 1</b>	<b>(start of the stair)</b>
<b>Top Level = Level 2</b>	<b>(determines the number of rises and runs)</b>
<b>Multistory Top Level = Roof</b>	<b>(the stair repeats until it reaches the roof)</b>
<b>Width = 42"</b>	

**Finish Stair:** **Save and Exit sketch** mode to finish the stair

Spring 2011

**Section Check:** Next create a section to check the stair. **View > Section**

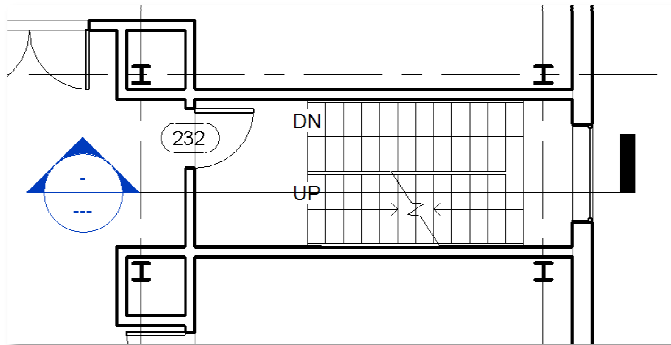

**Identify Conflicts:** Two conflicts are noted: The Stair conflicts with the exterior wall and the floor slab and beam to not permit enough headroom at the landing

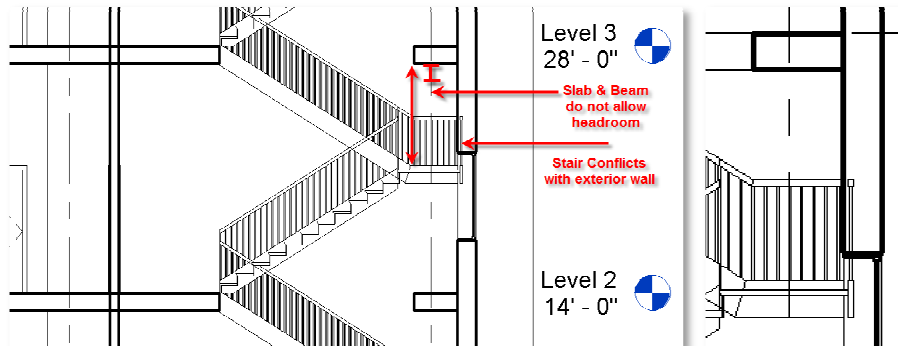

**Solution 1:** Shift the stair, wall and door over 3'-6" clear of the slab and beam

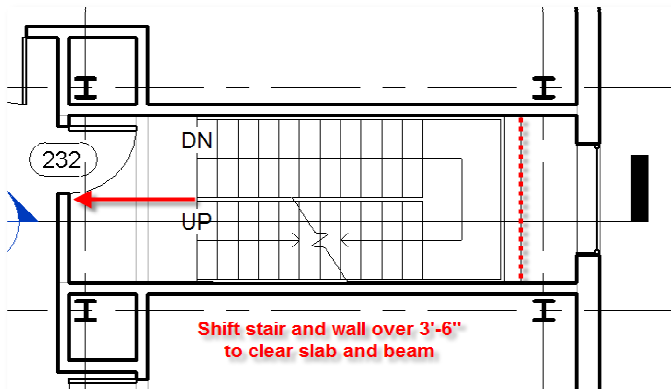

Plan View

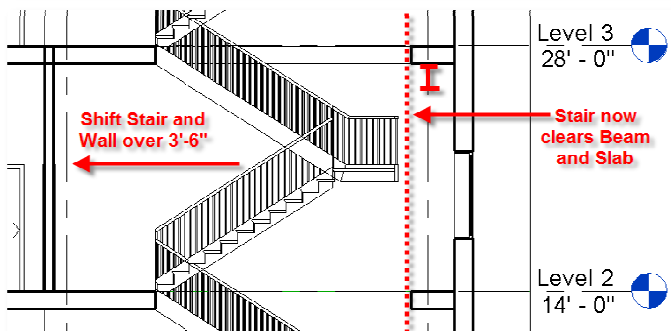

Section View

Spring 2011

**Solution 2:** Reframe the structure to remove the beam and extend the shaft opening.

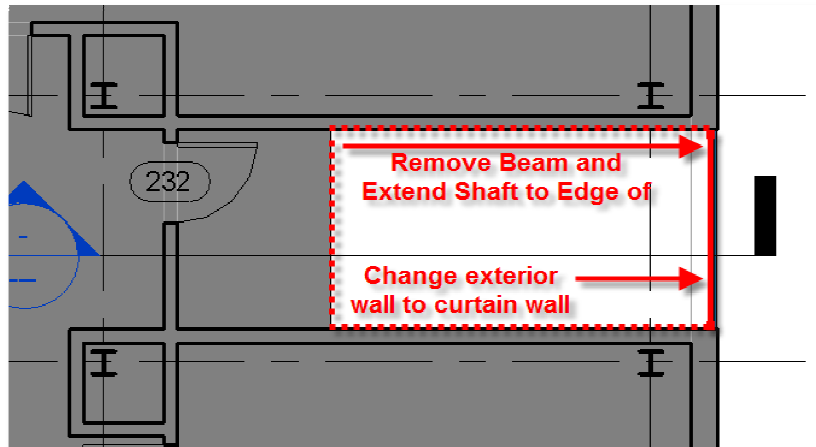

**Change** the **exterior wall** to a **thinner curtain wall** to clear the stair

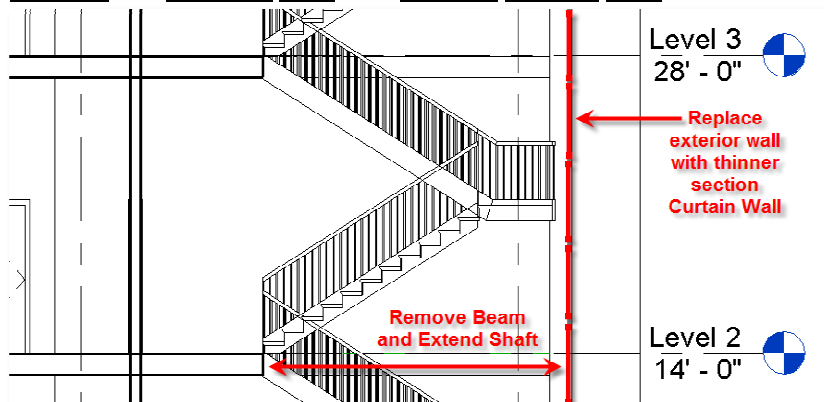

The problem is resolved without moving the stair

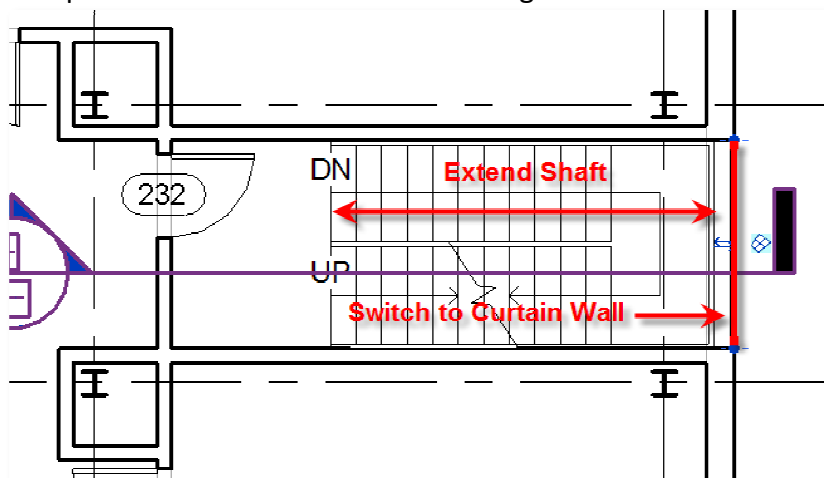

**Note:** Often the resolution of an issue can be taken as a design opportunity. In this instance a curtain wall has been added which will create additional interest to the exterior facade.

Spring 2011

**Solution 1:** Shift the stair, wall and door over 3'-6" clear of the slab and beam

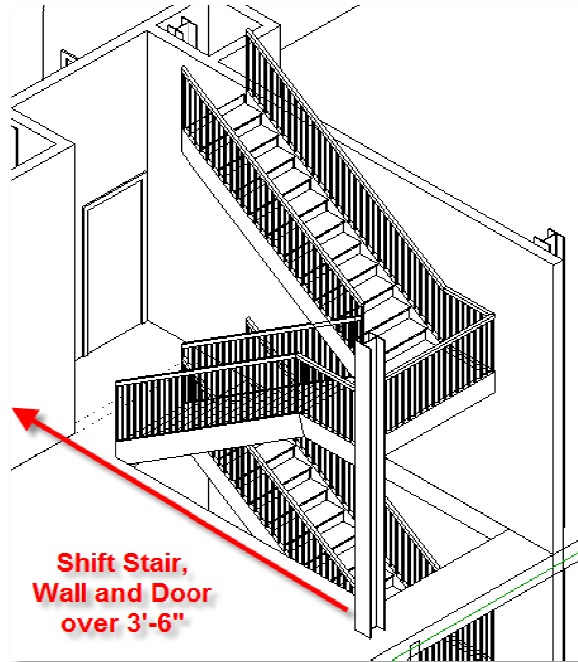

**Solution 2:** Reframe the structure to remove the beam and extend the shaft opening. Replace the exterior wall with a curtain wall

