



Computers 3: Revit
IDC : Institute of Design and Construction

Building Information Modeling with Revit 2013
Day 01

Professor Paul C. King, RA, AIA, ARA
Prof.Paul.King@Gmail.com

<http://professorpaulking.wordpress.com/>

<http://students.autodesk.com/>

Day 01

Project Tour

- Change Units
- Take a Tour

Project Browser

- Floor Plans
- Ceiling Plans
- 3D Views
- Elevations
- Sections
- Renderings

Creating Views

- 3D Views
- Section
- Callout
- Plan Views
- Elevation
- Drafting view
- Duplicate
- Legends
- Schedules
- Scope Box

Orient to View

Scavenger Hunt

Sheet Layout

BIM & Parametrics

Wrap up

Manage - Project Units

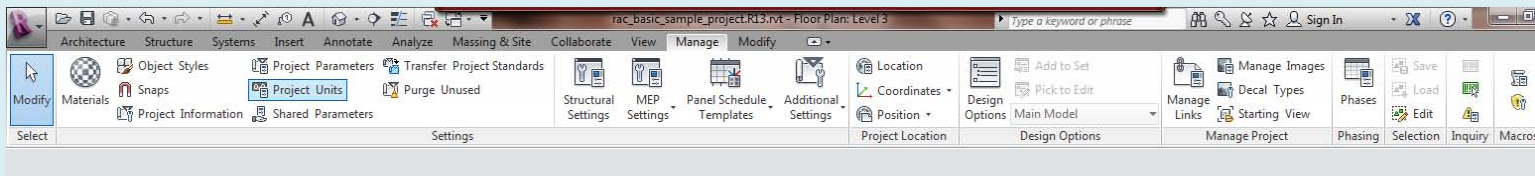

Changing project units from Metric to English

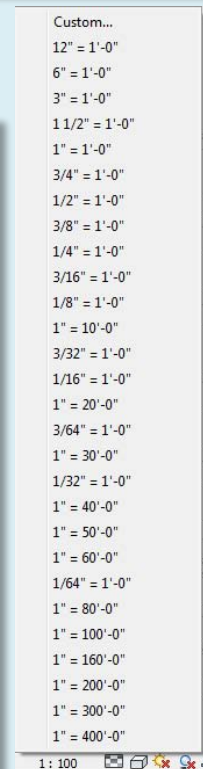
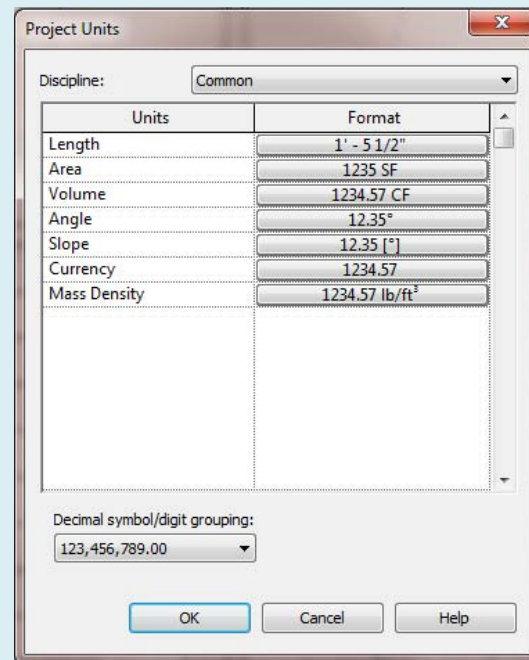
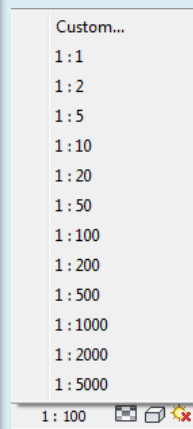
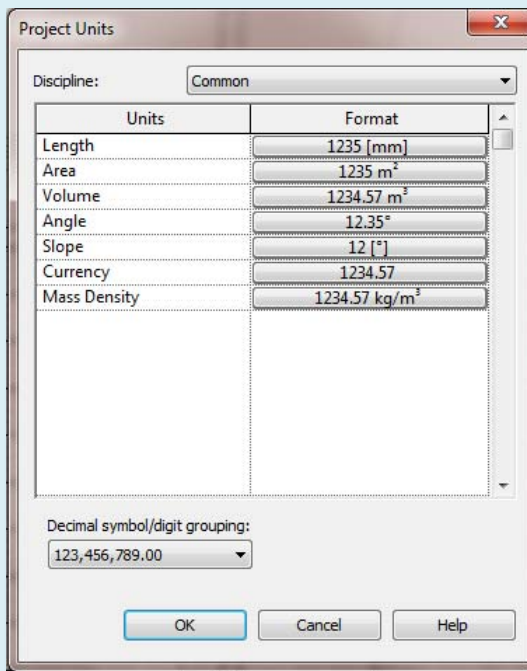

Lets take a project tour

Day 01

- Project Tour**
- Change Units
 - Take a Tour**

- Project Browser**
- Floor Plans
 - Ceiling Plans
 - 3D Views
 - Elevations
 - Sections
 - Renderings

- Creating Views**
- 3D Views
 - Section
 - Callout
 - Plan Views
 - Elevation
 - Drafting view
 - Duplicate
 - Legends
 - Schedules
 - Scope Box

- Orient to View**
- Scavenger Hunt**
- Sheet Layout**
- BIM & Parametrics**
- Wrap up**

Revit
Computers 3

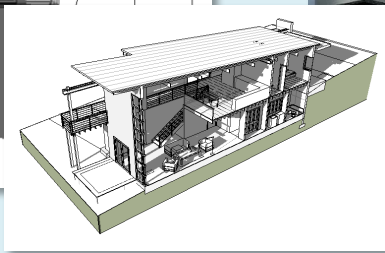
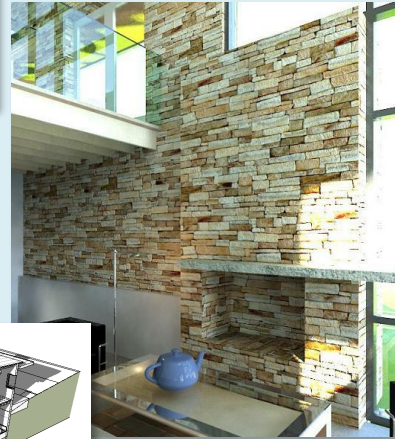
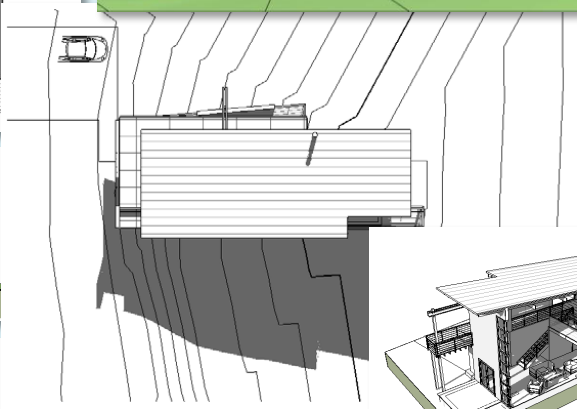
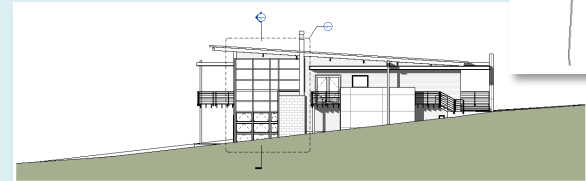
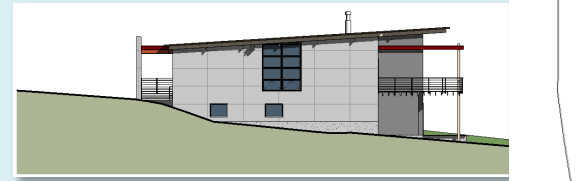
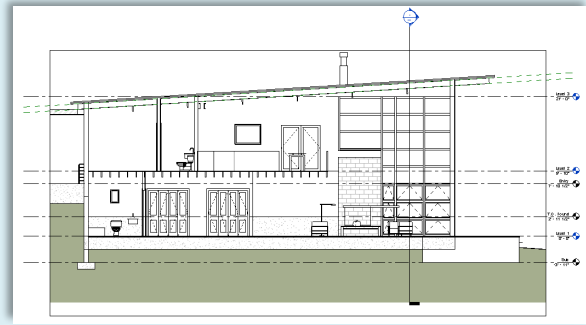

Project Browser – Floor Plans

Day 01

- Project Tour
 - Change Units
 - Take a Tour

Project Browser

- Floor Plans
- Ceiling Plans
- 3D Views
- Elevations
- Sections
- Renderings

Creating Views

- 3D Views
- Section
- Callout
- Plan Views
- Elevation
- Drafting view
- Duplicate
- Legends
- Schedules
- Scope Box

Orient to View

Scavenger Hunt

Sheet Layout

BIM & Parametrics

Wrap up

Revit
Computers 3

Project Browser

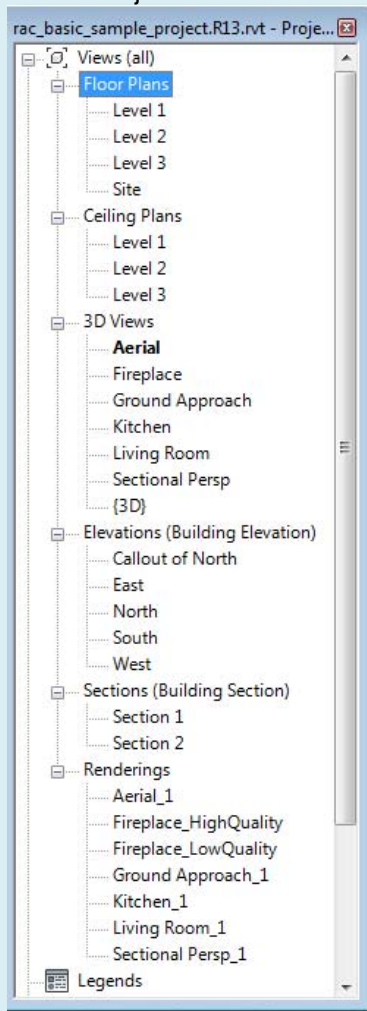

- Level 1 & Siteplan
- Scales 1/8" = 1'-0"
- Area Plan with Key

- Visual Styles
 - Hidden Line

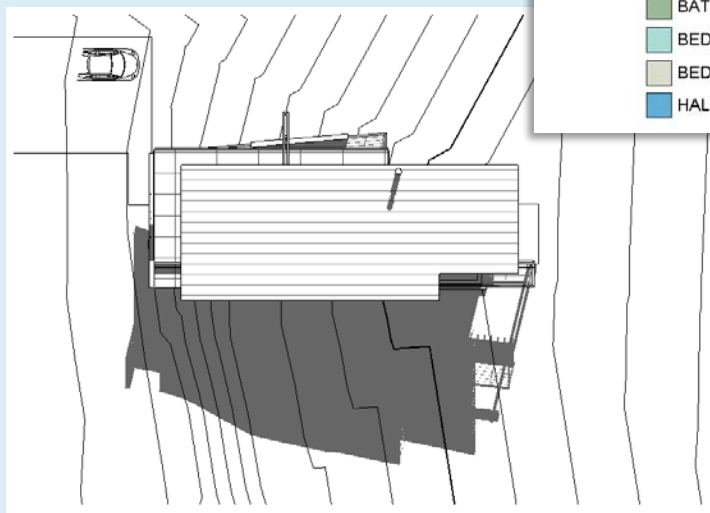
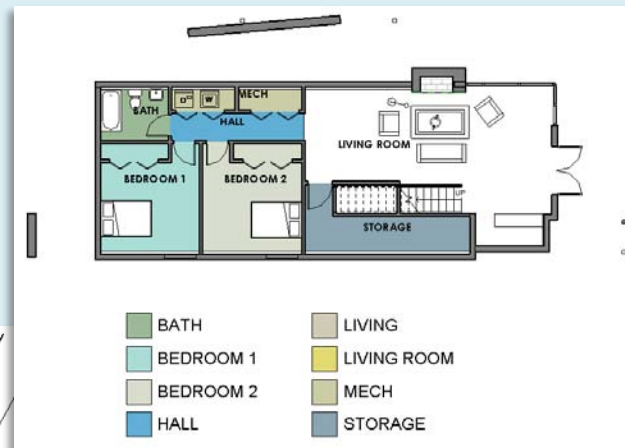

- Site Plan with Shadows

Project Browser – Floor Plans

Day 01

- Project Tour
 - Change Units
 - Take a Tour

Project Browser

- Floor Plans**
- Ceiling Plans
- 3D Views
- Elevations
- Sections
- Renderings

Creating Views

- 3D Views
- Section
- Callout
- Plan Views
- Elevation
- Drafting view
- Duplicate
- Legends
- Schedules
- Scope Box

Orient to View

Scavenger Hunt

Sheet Layout

BIM & Parametrics

Wrap up

Revit
Computers 3

Project Browser

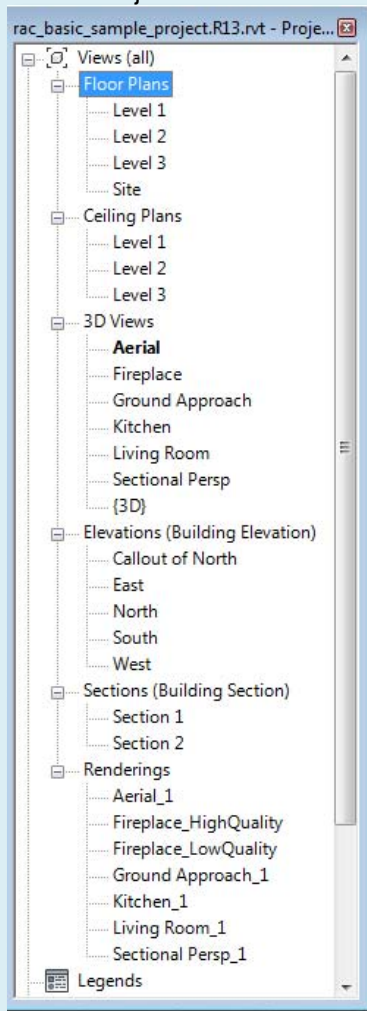

- **Level 2 & 3 (roof)**
- **Scales 1/8 = 1'-0**
- **Visual Styles**
 - **Hidden Line**

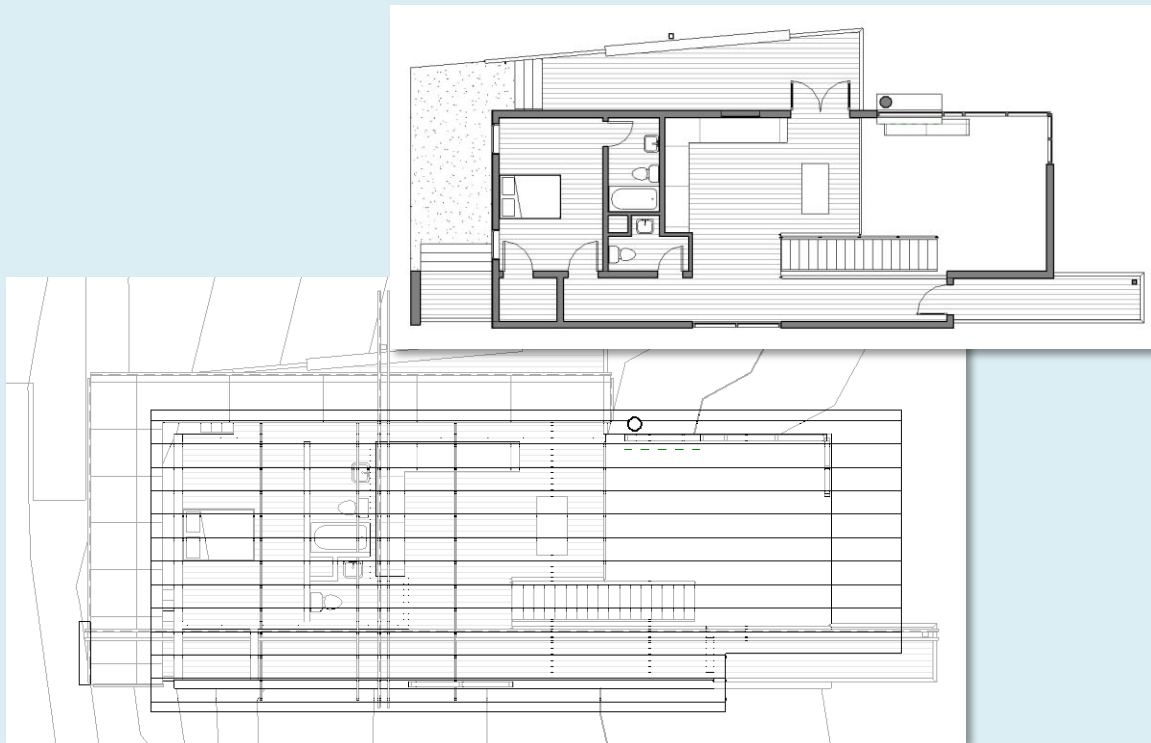

Project Browser – Ceiling Plans

Day 01

- Project Tour
 - Change Units
 - Take a Tour

- Project Browser
 - Floor Plans
 - Ceiling Plans
 - 3D Views
 - Elevations
 - Sections
 - Renderings

- Creating Views
 - 3D Views
 - Section
 - Callout
 - Plan Views
 - Elevation
 - Drafting view
 - Duplicate
 - Legends
 - Schedules
 - Scope Box

Orient to View

Scavenger Hunt

Sheet Layout

BIM & Parametrics

Wrap up

Revit
Computers 3

Institute of Design
and Construction

Project Browser

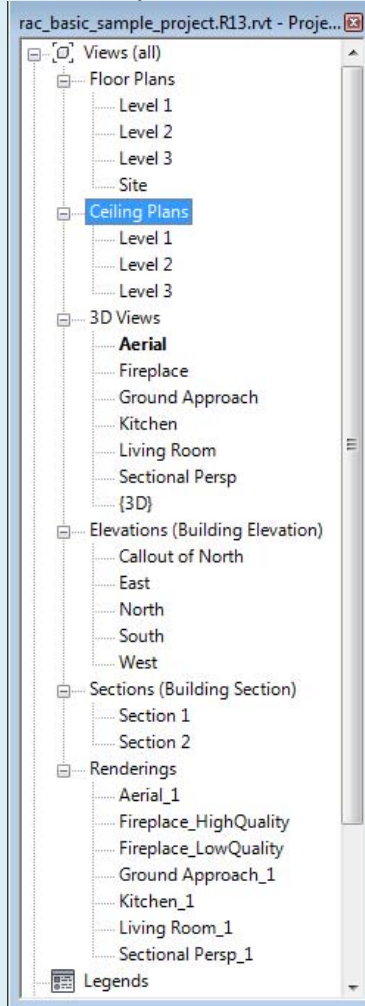

- Level 1 & 2
- Scales 1/8" = 1'-0"
- Visual Styles
 - Hidden Line

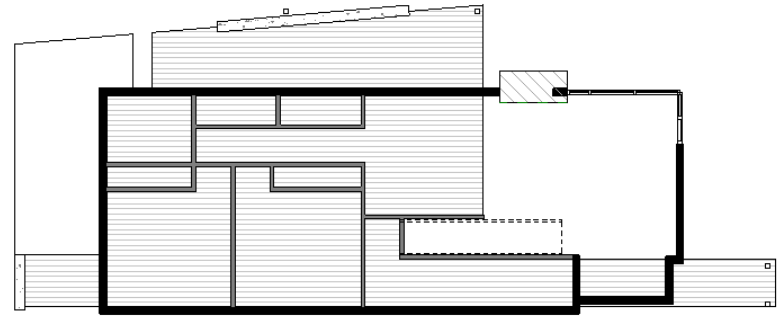
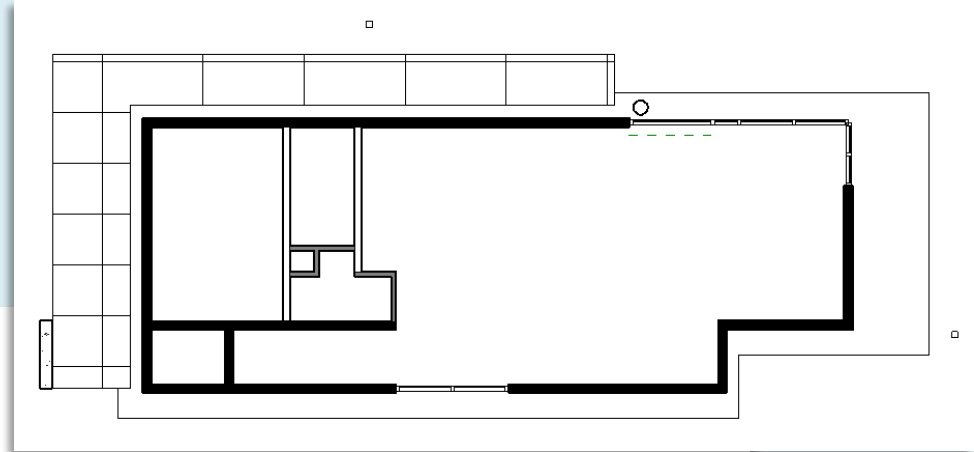
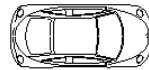

RAC_Basic_Sample_Project.rvt

Day 01

- Project Tour
 - Change Units
 - Take a Tour

Project Browser

- Floor Plans
- Ceiling Plans
- 3D Views
- Elevations
- Sections
- Renderings

Creating Views

- 3D Views
- Section
- Callout
- Plan Views
- Elevation
- Drafting view
- Duplicate
- Legends
- Schedules
- Scope Box

Orient to View

Scavenger Hunt

Sheet Layout

BIM & Parametrics

Wrap up

Project Browser – 3D Views (perspective)

Project Browser

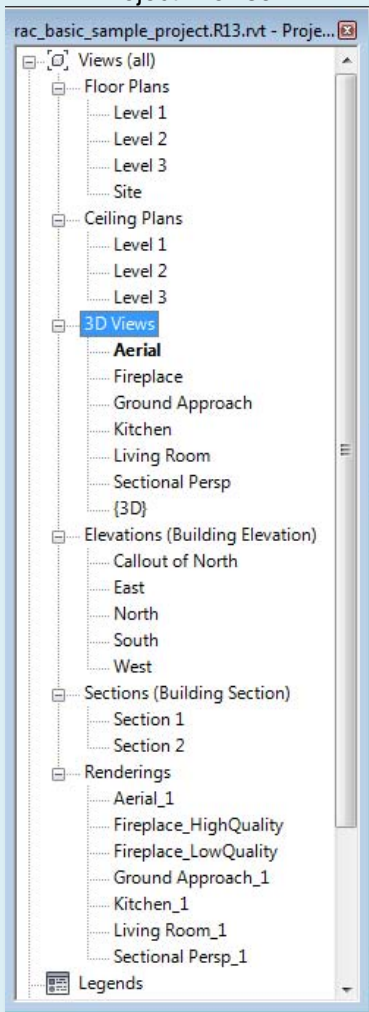

- Aerial & Ground Approach Perspective Views
- Visual Styles
 - Realistic & Shaded with Edges



RAC_Basic_Sample_Project.rvt

Project Browser – 3D Views (perspective)

Day 01

- Project Tour
 - Change Units
 - Take a Tour

Project Browser

- Floor Plans
- Ceiling Plans
- 3D Views**
- Elevations
- Sections
- Renderings

Creating Views

- 3D Views
- Section
- Callout
- Plan Views
- Elevation
- Drafting view
- Duplicate
- Legends
- Schedules
- Scope Box

Orient to View

Scavenger Hunt

Sheet Layout

BIM & Parametrics

Wrap up

Revit
Computers 3

Project Browser

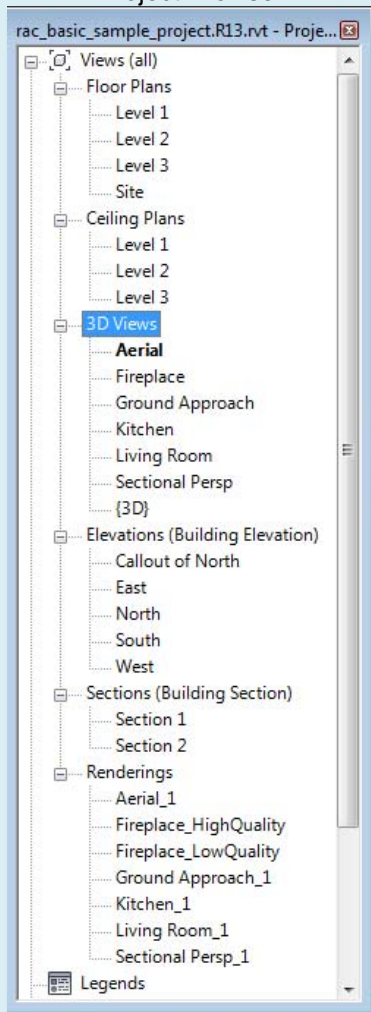

- **Fireplace and Section Perspective Views**
- **Visual Styles**
 - **Hidden Line & Hidden Line with Shadows**

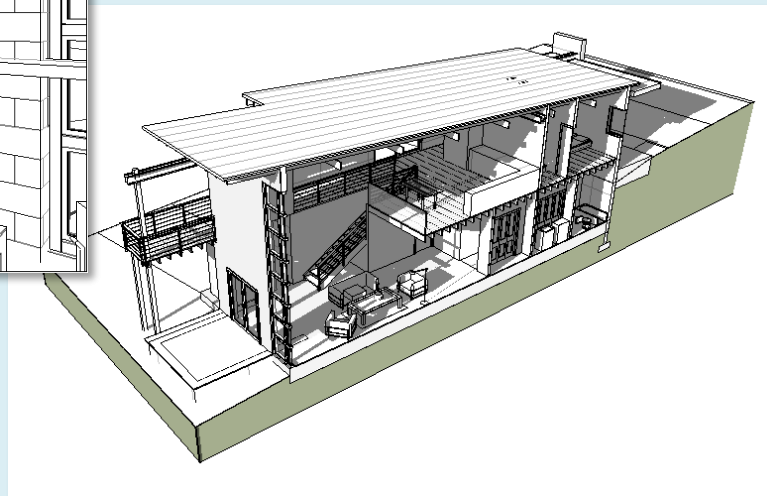

Day 01

- Project Tour
 - Change Units
 - Take a Tour

Project Browser

- Floor Plans
- Ceiling Plans
- 3D Views
- Elevations
- Sections
- Renderings

Creating Views

- 3D Views
- Section
- Callout
- Plan Views
- Elevation
- Drafting view
- Duplicate
- Legends
- Schedules
- Scope Box

Orient to View

Scavenger Hunt

Sheet Layout

BIM & Parametrics

Wrap up

Project Browser – 3D Views (perspective)

Project Browser

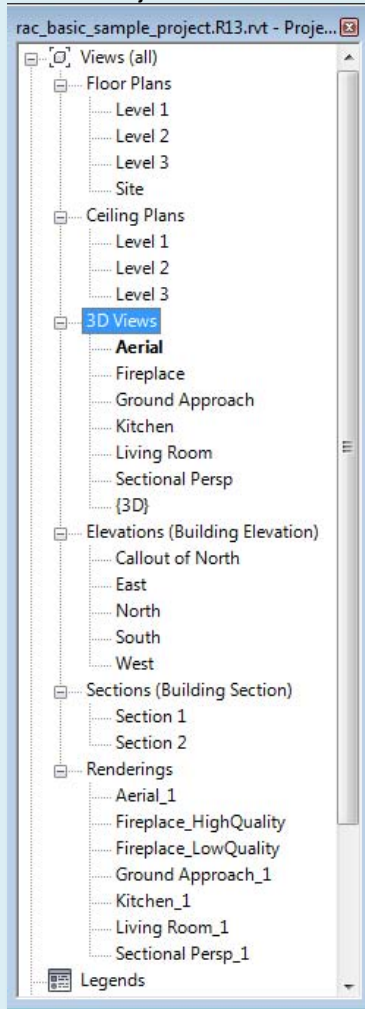

- **Fireplace and Kitchen Perspective Views**
- **Visual Styles**
 - **Realistic & Shaded with Edges**



Day 01

- Project Tour
 - Change Units
 - Take a Tour

Project Browser

- Floor Plans
- Ceiling Plans
- 3D Views
- Elevations**
- Sections
- Renderings

Creating Views

- 3D Views
- Section
- Callout
- Plan Views
- Elevation
- Drafting view
- Duplicate
- Legends
- Schedules
- Scope Box

Orient to View

Scavenger Hunt

Sheet Layout

BIM & Parametrics

Wrap up

Project Browser - Elevations (Building Elevations)

Project Browser

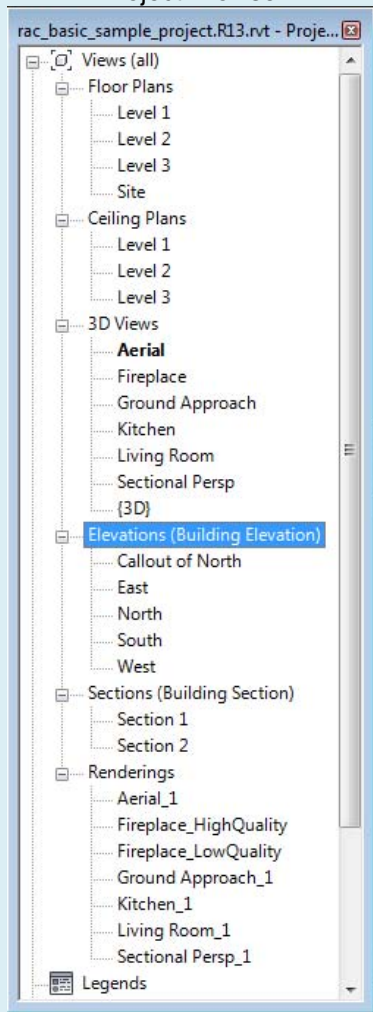

- **South & North Elevations & Callout of North**
- **Scales 1/8" = 1'-0", 1/4" = 1'-0" & 1/2" = 1'-0"**
- **Visual Styles**
 - **Shaded with Edges & Hidden Line with Shadows**



Day 01

- Project Tour
 - Change Units
 - Take a Tour

Project Browser

- Floor Plans
- Ceiling Plans
- 3D Views
- Elevations**
- Sections
- Renderings

Creating Views

- 3D Views
- Section
- Callout
- Plan Views
- Elevation
- Drafting view
- Duplicate
- Legends
- Schedules
- Scope Box

Orient to View

Scavenger Hunt

Sheet Layout

BIM & Parametrics

Wrap up

Project Browser – Elevations (Building Elevations)

Project Browser

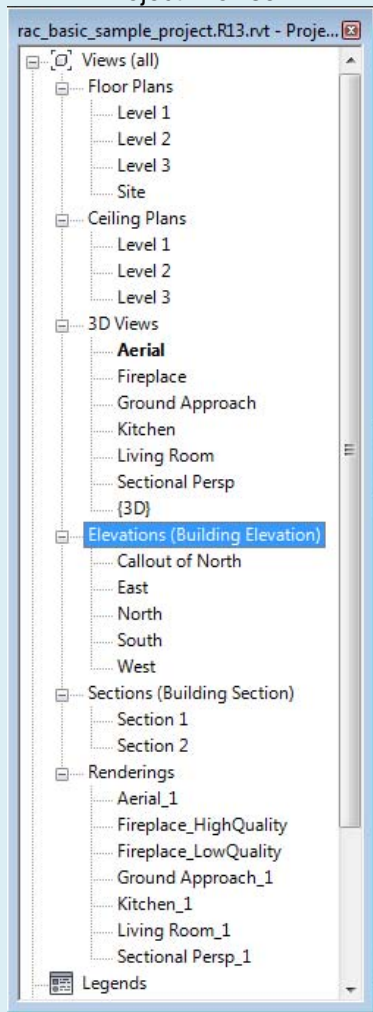

- **East & West Elevations**
- **Scale 1/8 = 1'-0"**
- **Visual Styles**
 - **Shaded with Edges & Hidden Line with Shadows**

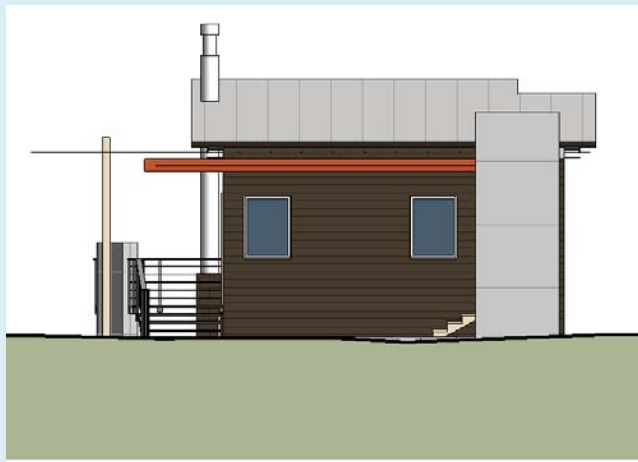

Day 01

- Project Tour
 - Change Units
 - Take a Tour

Project Browser

- Floor Plans
- Ceiling Plans
- 3D Views
- Elevations
- Sections**
- Renderings

Creating Views

- 3D Views
- Section
- Callout
- Plan Views
- Elevation
- Drafting view
- Duplicate
- Legends
- Schedules
- Scope Box

Orient to View

Scavenger Hunt

Sheet Layout

BIM & Parametrics

Wrap up

Revit
Computers 3

Project Browser – Sections (Building Sections)

Project Browser

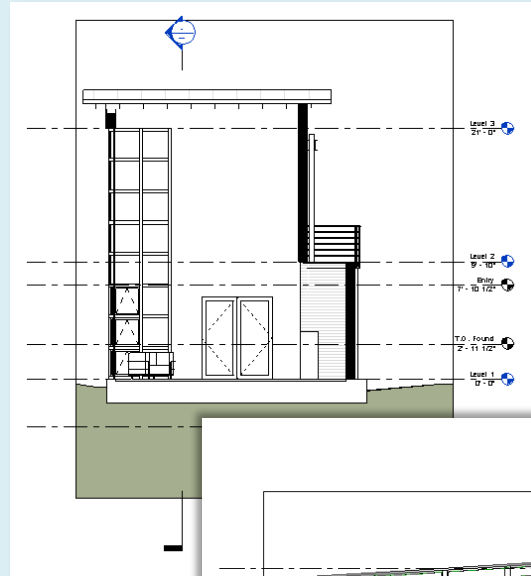
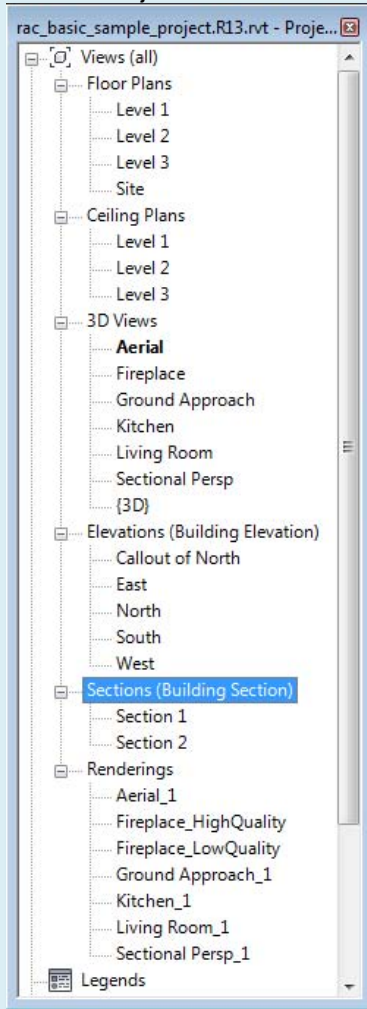

- Levels
- Section Markers
- Scale 1/4" = 1'-0"
- Visual Style
 - Hidden Lines

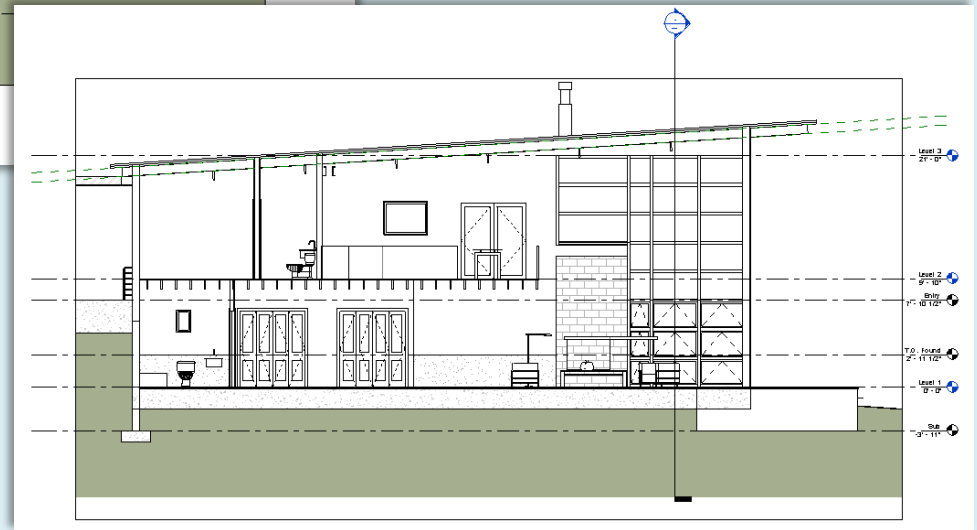

Day 01

- Project Tour
 - Change Units
 - Take a Tour

Project Browser

- Floor Plans
- Ceiling Plans
- 3D Views
- Elevations
- Sections
- Renderings . . .

Creating Views

- 3D Views
- Section
- Callout
- Plan Views
- Elevation
- Drafting view
- Duplicate
- Legends
- Schedules
- Scope Box

Orient to View

Scavenger Hunt

Sheet Layout

BIM & Parametrics

Wrap up

Project Browser – Renderings (raster images)

Project Browser

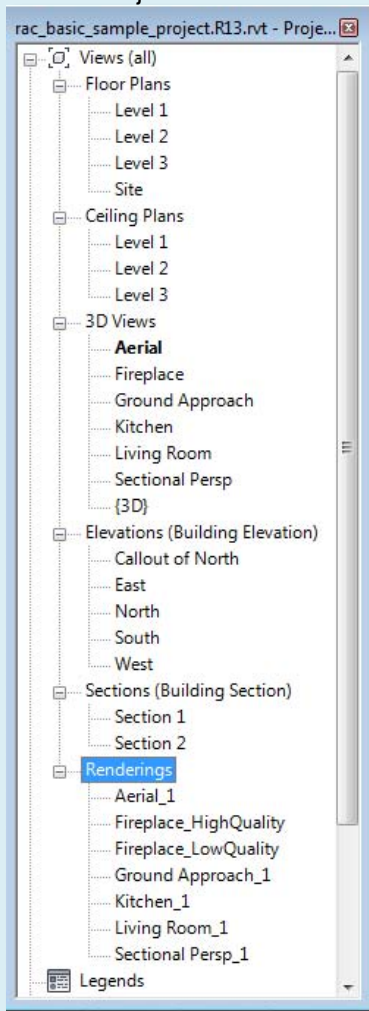

- Section Perspective
- Ground Approach



Day 01

- Project Tour
 - Change Units
 - Take a Tour

Project Browser

- Floor Plans
- Ceiling Plans
- 3D Views
- Elevations
- Sections
- Renderings ...

Creating Views

- 3D Views
- Section
- Callout
- Plan Views
- Elevation
- Drafting view
- Duplicate
- Legends
- Schedules
- Scope Box

Orient to View

Scavenger Hunt

Sheet Layout

BIM & Parametrics

Wrap up

Project Browser – Renderings (raster images)

Project Browser

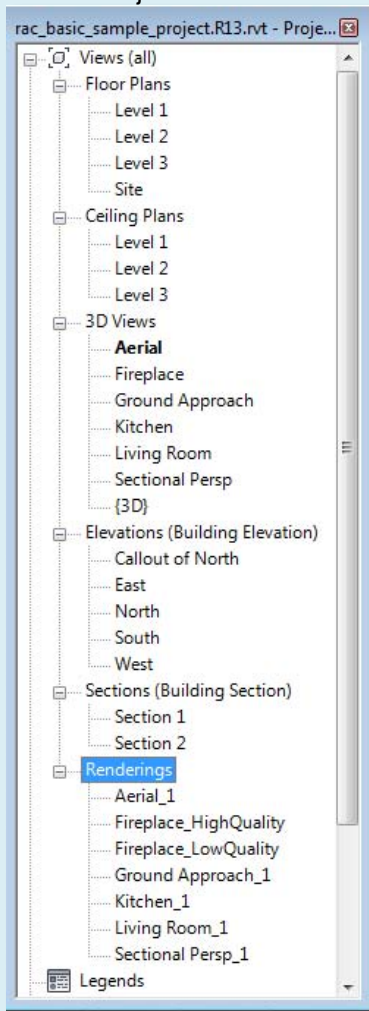

- Realistic Renderings of the Fireplace
 - High Quality (brighter image)
 - Low Quality

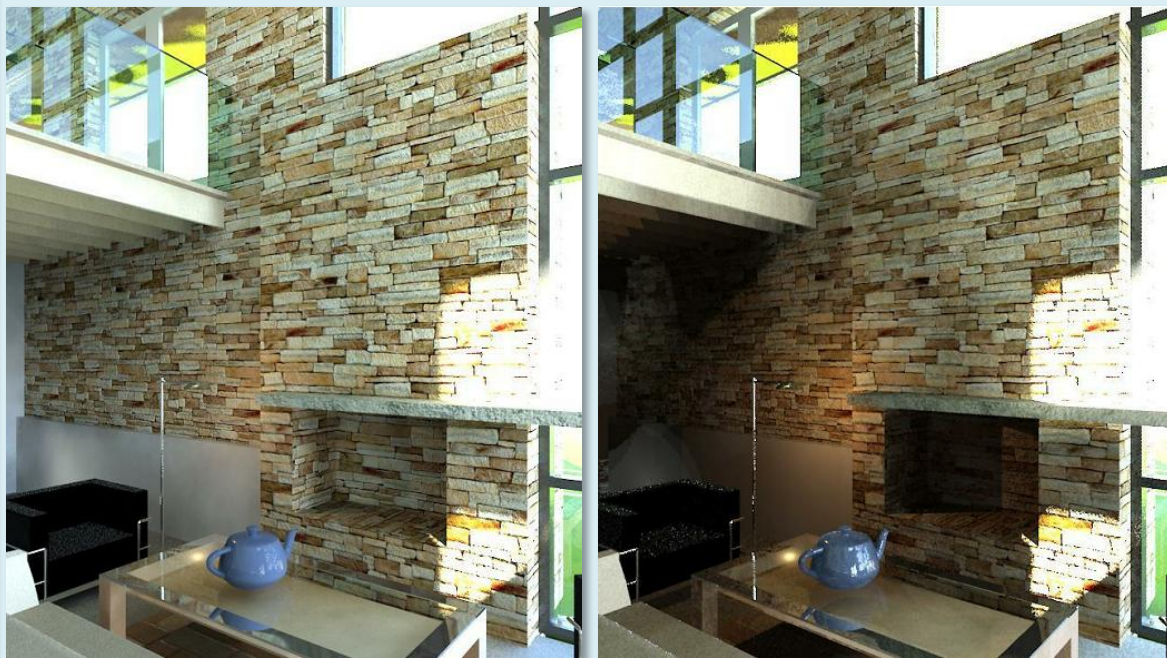

Day 01

Project Tour

- Change Units
- Take a Tour

Project Browser

- Floor Plans
- Ceiling Plans
- 3D Views
- Elevations
- Sections
- **Renderings ...**

Creating Views

- 3D Views
- Section
- Callout
- Plan Views
- Elevation
- Drafting view
- Duplicate
- Legends
- Schedules
- Scope Box

Orient to View

Scavenger Hunt

Sheet Layout

BIM & Parametrics

Wrap up

Project Browser – Renderings (raster images)

Project Browser

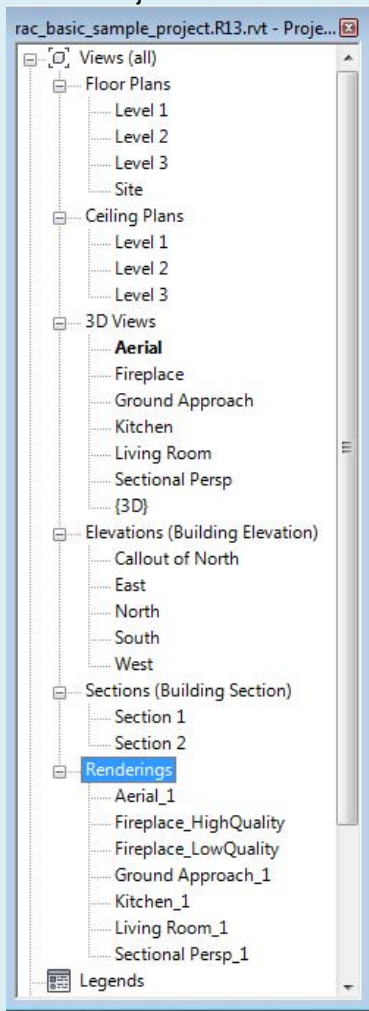

- **Kitchen on upper level**
- **Living Room below**



Creating New Views – 3D

Quick Access Toolbar

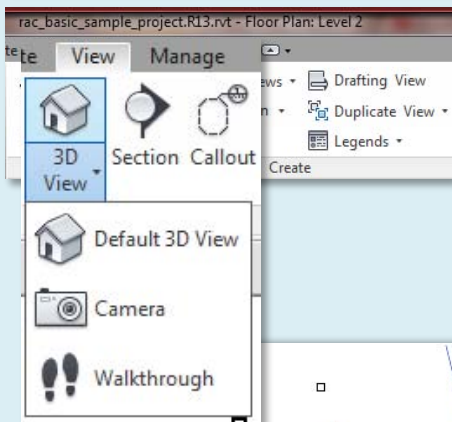
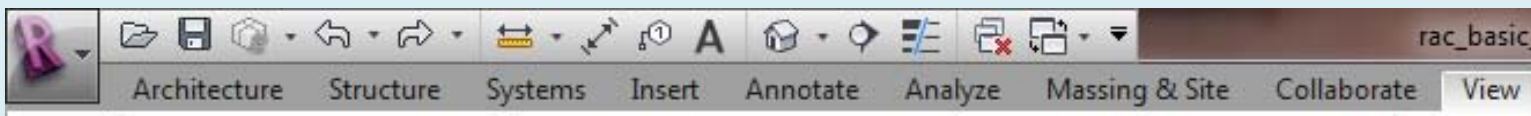

- Isometric
- Perspectives
- Walkthroughs

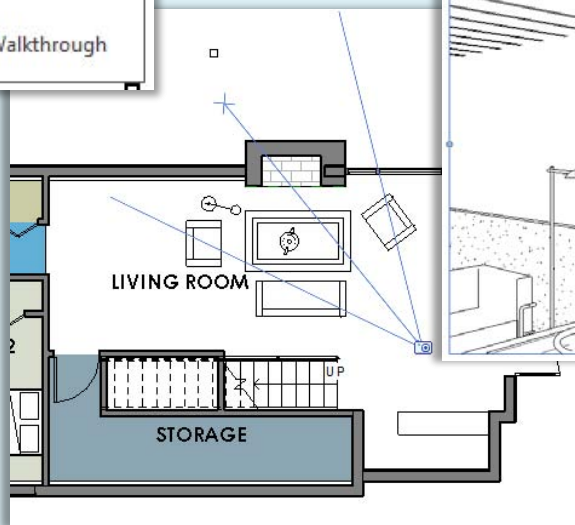
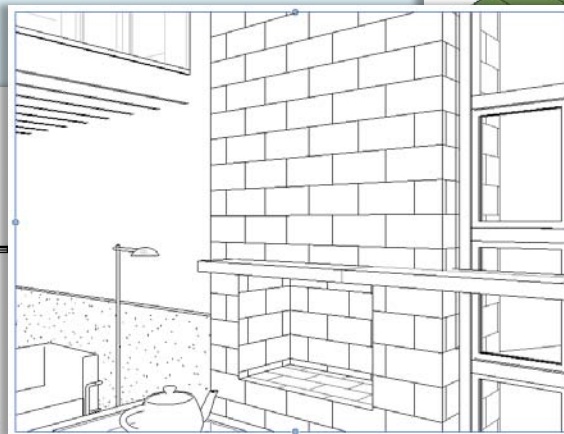
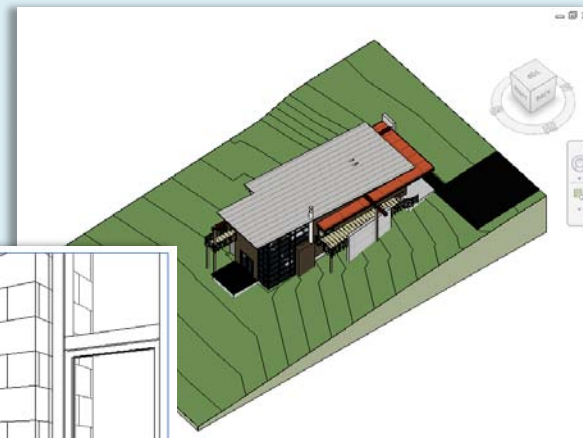

Day 01

Project Tour

- Change Units
- Take a Tour

Project Browser

- Floor Plans
- Ceiling Plans
- 3D Views
- Elevations
- Sections
- Renderings

Creating Views

- 3D Views
- Section
- Callout
- Plan Views
- Elevation
- Drafting view
- Duplicate
- Legends
- Schedules
- Scope Box

Orient to View

Scavenger Hunt

Sheet Layout

BIM & Parametrics

Wrap up

Revit
Computers 3

Creating New Views – 3D

Quick Access Toolbar

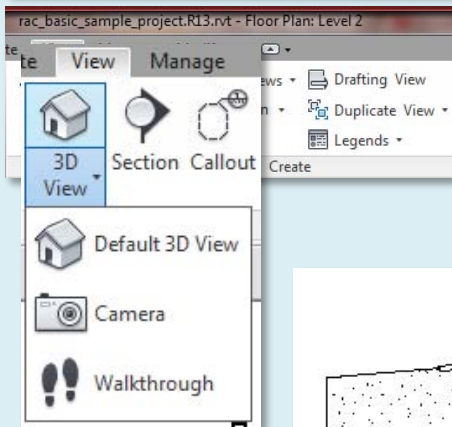

- Isometric
- Perspectives
- Walkthroughs

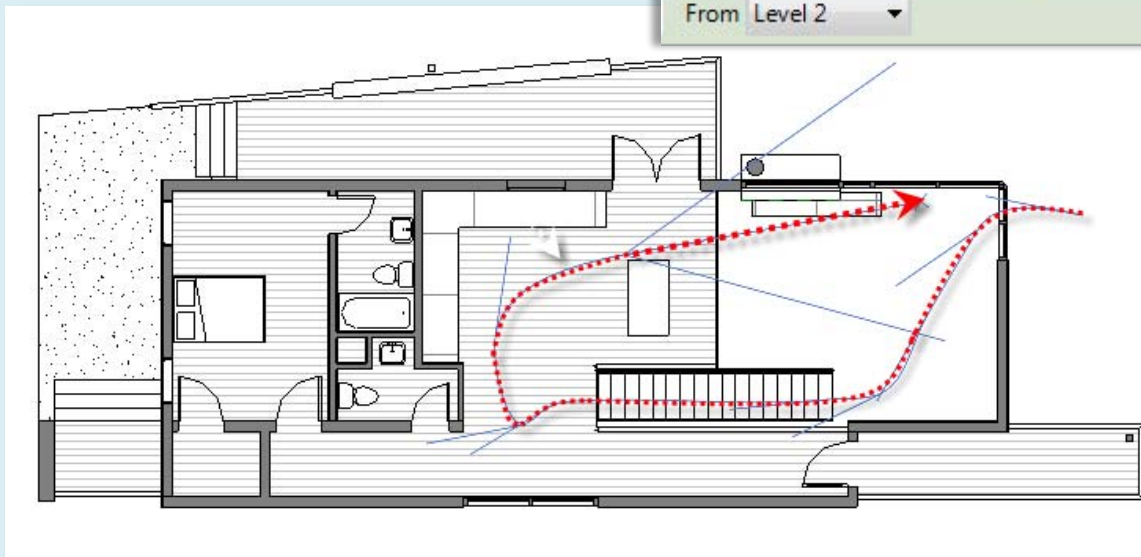
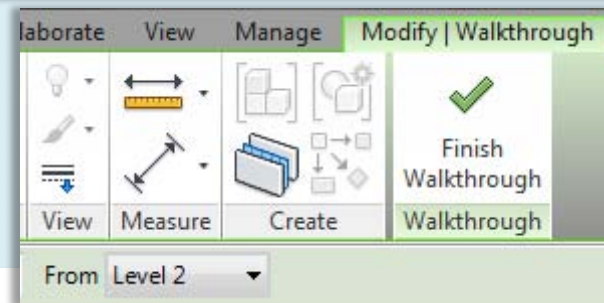

Day 01

Project Tour

- Change Units
- Take a Tour

Project Browser

- Floor Plans
- Ceiling Plans
- 3D Views
- Elevations
- Sections
- Renderings

Creating Views

- 3D Views
- Section
- Callout
- Plan Views
- Elevation
- Drafting view
- Duplicate
- Legends
- Schedules
- Scope Box

Orient to View

Scavenger Hunt

Sheet Layout

BIM & Parametrics

Wrap up

Revit
Computers 3

Creating New Views - Section

Quick Access Toolbar

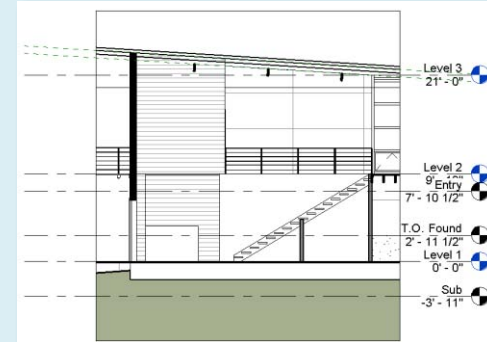
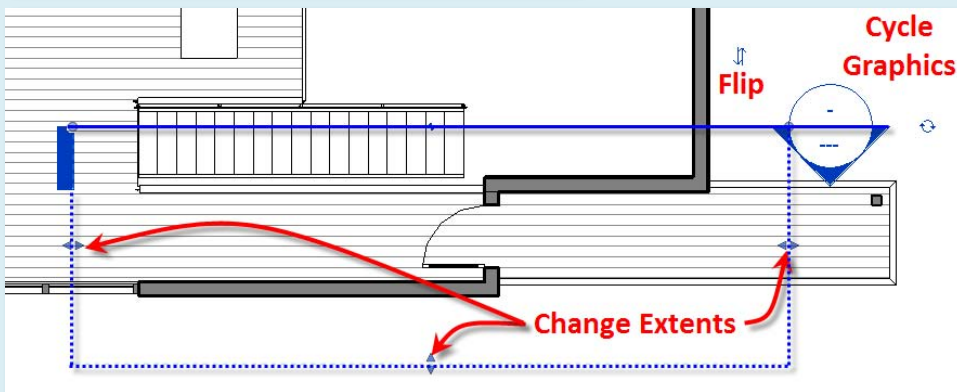
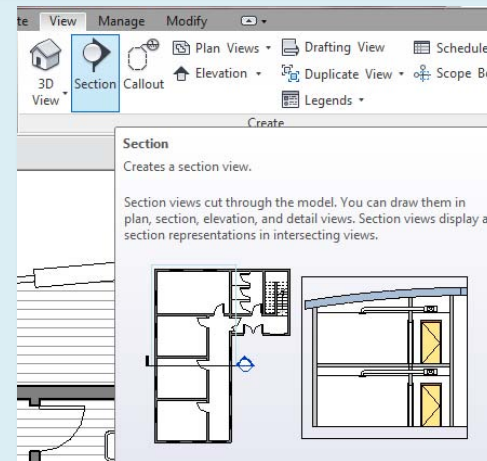
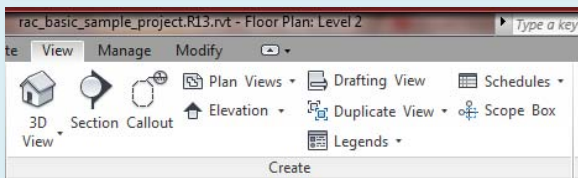
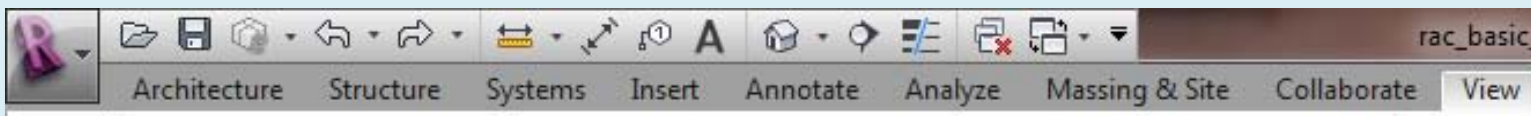

- **Section scale will match plan scale**

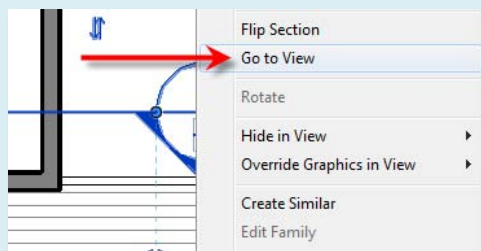

Day 01

Project Tour

- Change Units
- Take a Tour

Project Browser

- Floor Plans
- Ceiling Plans
- 3D Views
- Elevations
- Sections
- Renderings

Creating Views

- 3D Views
- **Section**
- Callout
- Plan Views
- Elevation
- Drafting view
- Duplicate
- Legends
- Schedules
- Scope Box

Orient to View

Scavenger Hunt

Sheet Layout

BIM & Parametrics

Wrap up

Revit
Computers 3

Day 01

- Project Tour
 - Change Units
 - Take a Tour

- Project Browser
 - Floor Plans
 - Ceiling Plans
 - 3D Views
 - Elevations
 - Sections
 - Renderings

Creating Views

- 3D Views
- Section
- Callout**
- Plan Views
- Elevation
- Drafting view
- Duplicate
- Legends
- Schedules
- Scope Box

Orient to View

Scavenger Hunt

Sheet Layout

BIM & Parametrics

Wrap up

Revit
Computers 3

Institute of Design
and Construction

Creating New Views - Callouts

Quick Access Toolbar

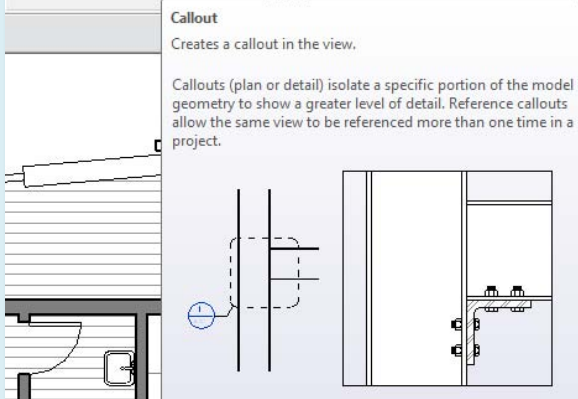
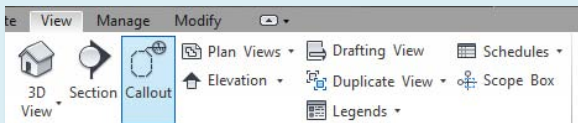
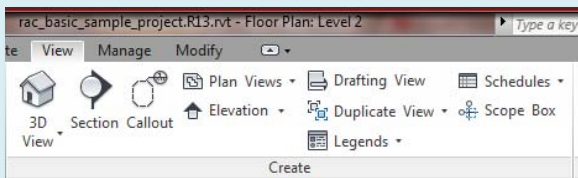
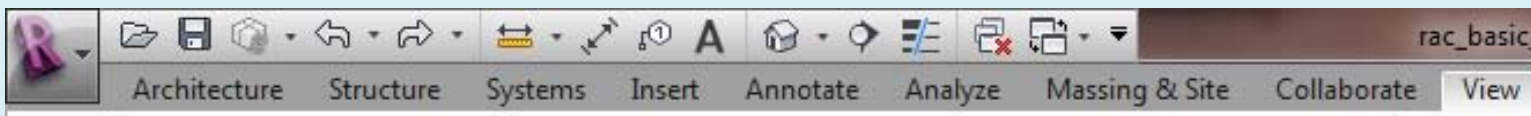

- **Scale of callout doubles**
- **1/8 plan creates a 1/4 callout**

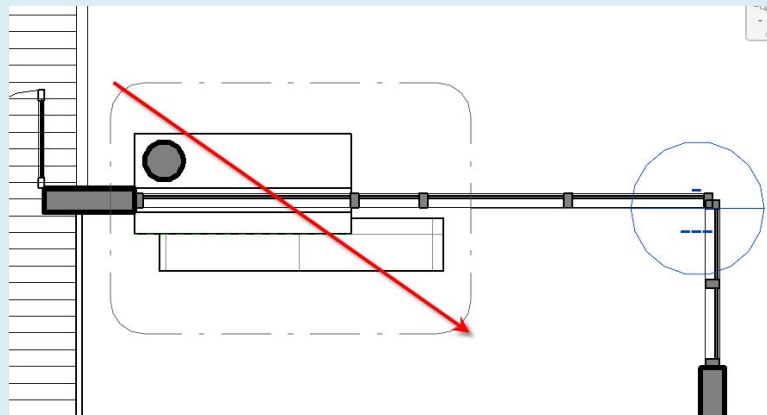
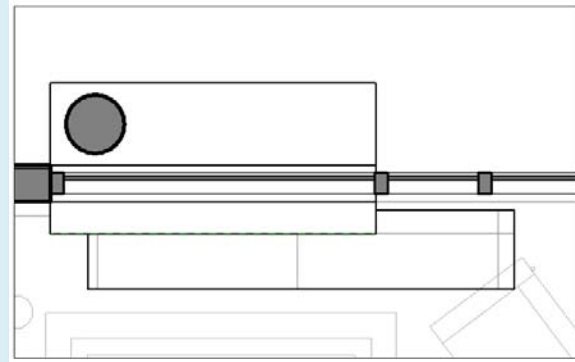

RAC_Basic_Sample_Project.rvt

Creating New Views – Plan Views

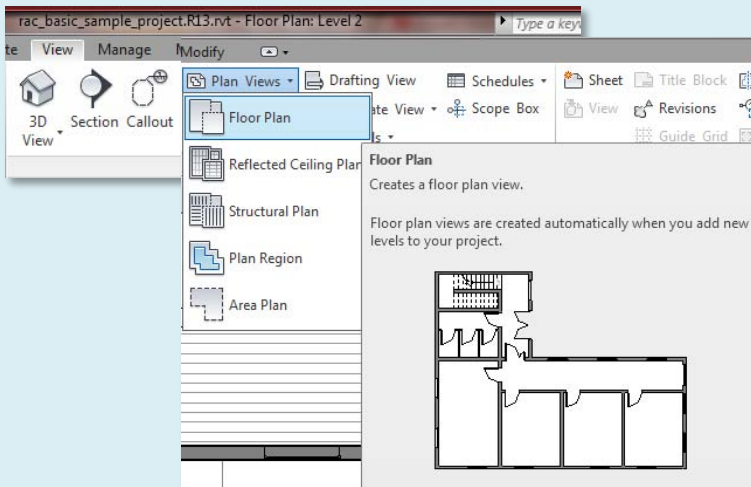
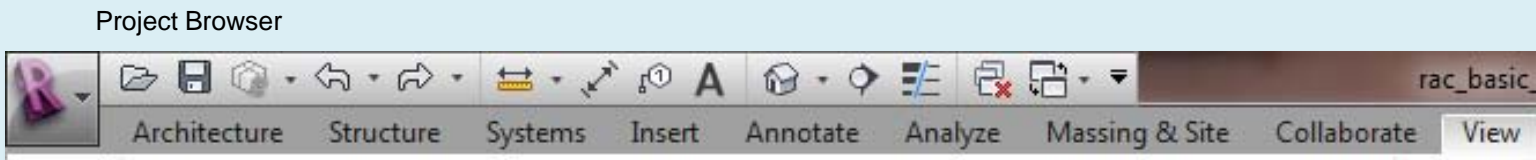

- You can only create a plan for any level that does not yet have an associated plan view

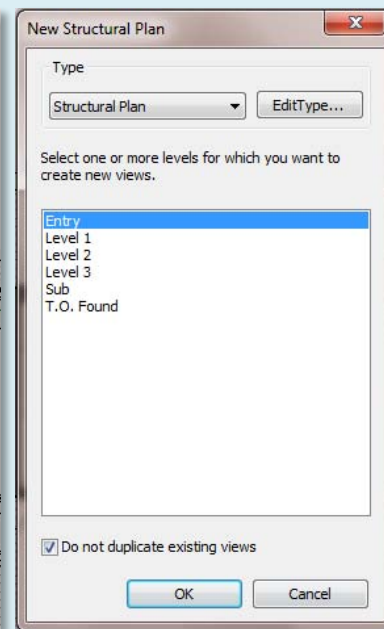
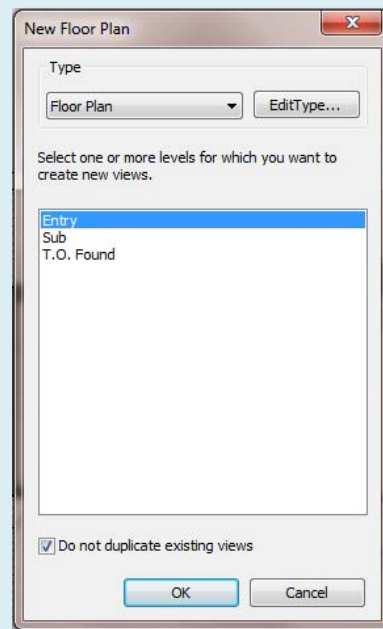

- Floor plans
- Reflected ceiling plans
- Structural plans
- Region plans
- Area plans

Day 01

Project Tour

- Change Units
- Take a Tour

Project Browser

- Floor Plans
- Ceiling Plans
- 3D Views
- Elevations
- Sections
- Renderings

Creating Views

- 3D Views
- Section
- Callout
- Plan Views
- Elevation
- Drafting view
- Duplicate
- Legends
- Schedules
- Scope Box

Orient to View

Scavenger Hunt

Sheet Layout

BIM & Parametrics

Wrap up

Creating New Views - Elevation

Day 01

Project Tour

- Change Units
- Take a Tour

Project Browser

- Floor Plans
- Ceiling Plans
- 3D Views
- Elevations
- Sections
- Renderings

Creating Views

- 3D Views
- Section
- Callout
- Plan Views
- Elevation**
- Drafting view
- Duplicate
- Legends
- Schedules
- Scope Box

Orient to View

Scavenger Hunt

Sheet Layout

BIM & Parametrics

Wrap up

Revit
Computers 3

Project Browser

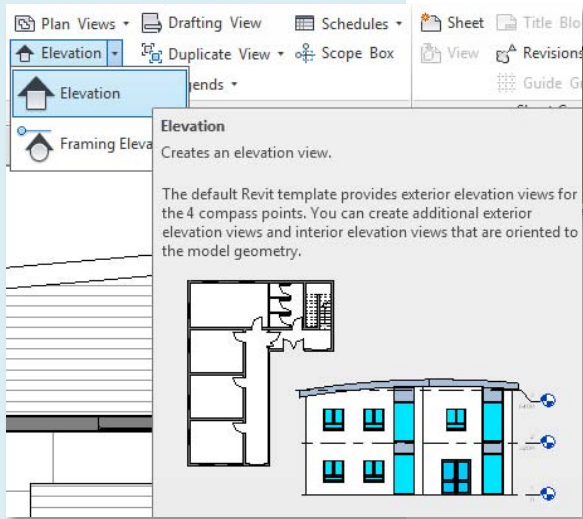
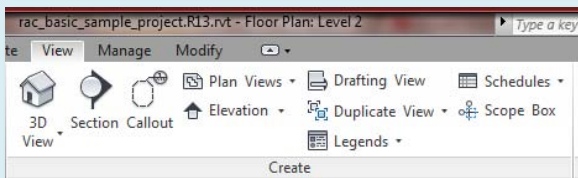
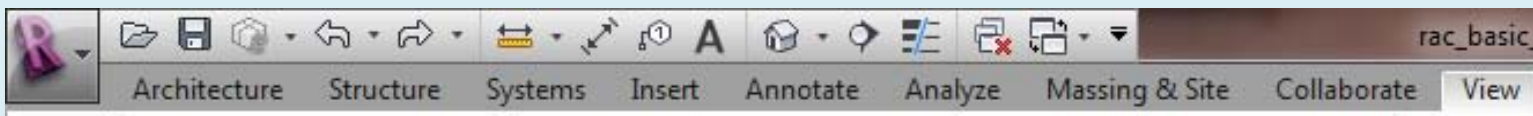

- **Scale typically matches floor plans**

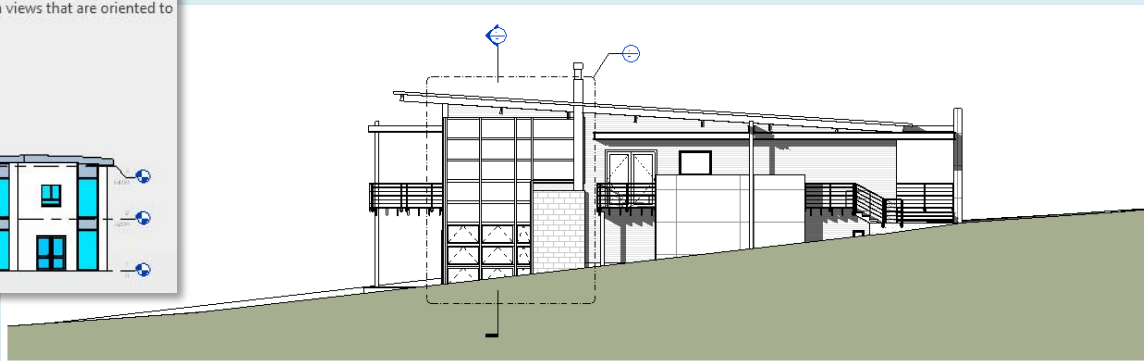
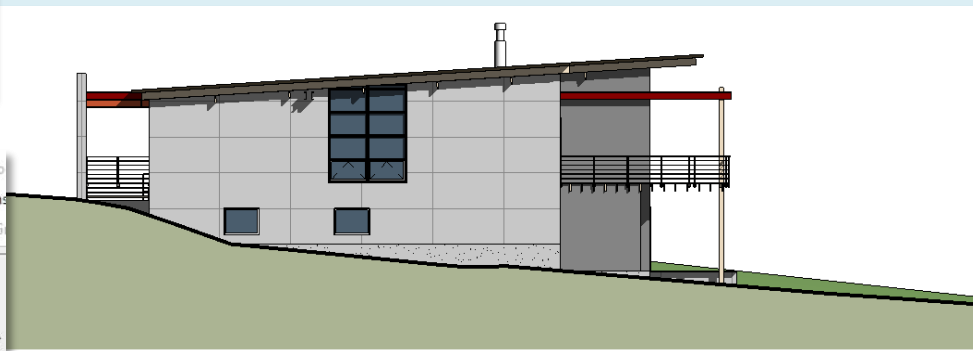

Creating New Views – Drafting Views

Quick Access Toolbar

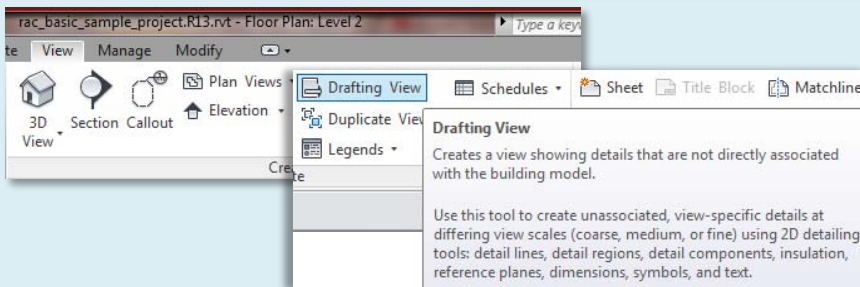
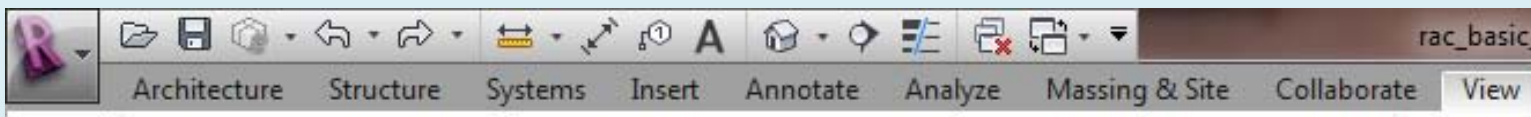

- **A non-associated view for creating details**

Day 01

Project Tour

- Change Units
- Take a Tour

Project Browser

- Floor Plans
- Ceiling Plans
- 3D Views
- Elevations
- Sections
- Renderings

Creating Views

- 3D Views
- Section
- Callout
- Plan Views
- Elevation
- **Drafting view**
- Duplicate
- Legends
- Schedules
- Scope Box

Orient to View

Scavenger Hunt

Sheet Layout

BIM & Parametrics

Wrap up

Revit
Computers 3

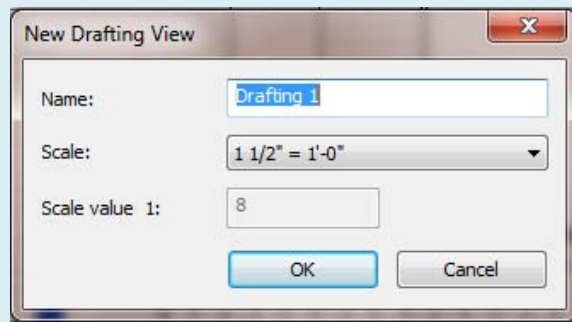
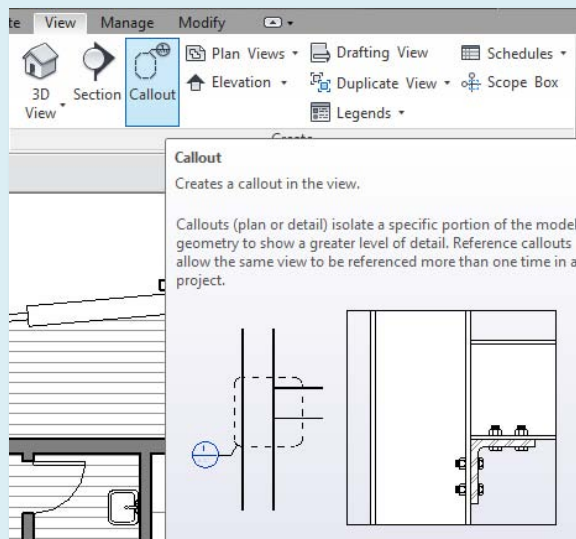

Creating New Views - Duplicate

Quick Access Toolbar

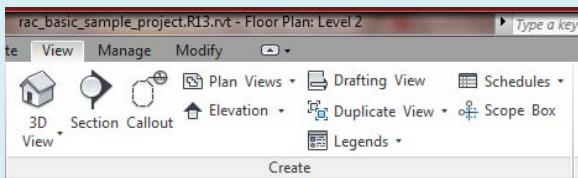
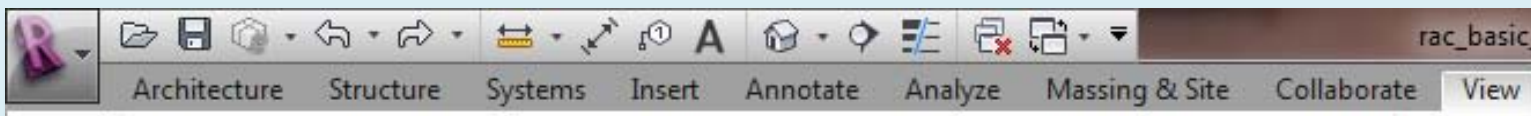

- Duplicate
- Duplicate with detailing
- Duplicate as Dependant

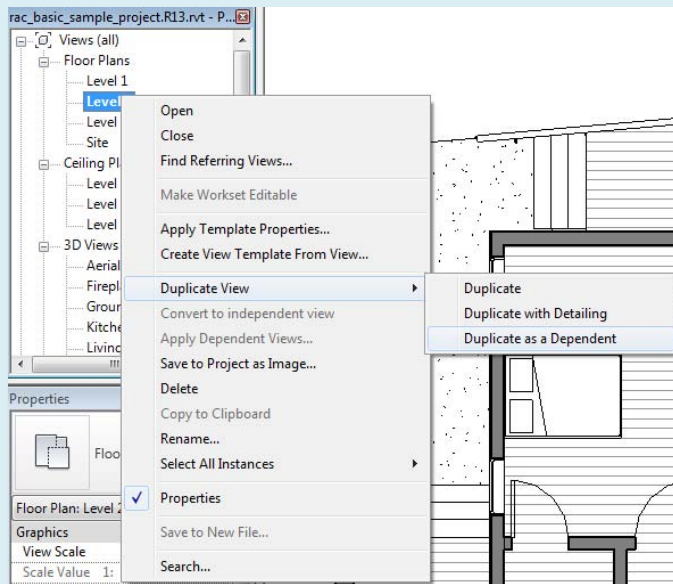
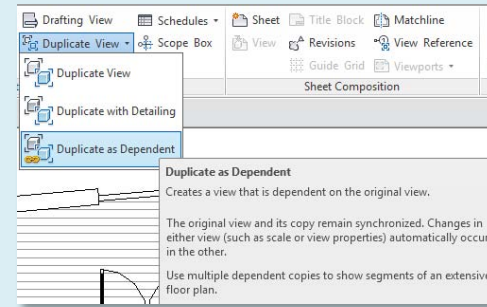
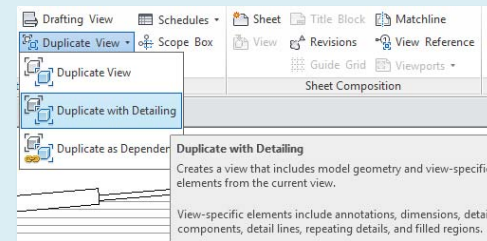
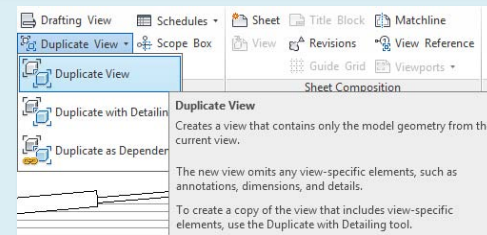

Day 01

Project Tour

- Change Units
- Take a Tour

Project Browser

- Floor Plans
- Ceiling Plans
- 3D Views
- Elevations
- Sections
- Renderings

Creating Views

- 3D Views
- Section
- Callout
- Plan Views
- Elevation
- **Duplicate**
- Legends
- Schedules
- Scope Box

Orient to View

Scavenger Hunt

Sheet Layout

BIM & Parametrics

Wrap up

Revit
Computers 3

Day 01

- Project Tour
 - Change Units
 - Take a Tour

- Project Browser
 - Floor Plans
 - Ceiling Plans
 - 3D Views
 - Elevations
 - Sections
 - Renderings

- Creating Views
 - 3D Views
 - Section
 - Callout
 - Plan Views
 - Elevation
 - Drafting view
 - Duplicate
 - Legends**
 - Schedules
 - Scope Box

- Orient to View
- Scavenger Hunt
- Sheet Layout
- BIM & Parametrics
- Wrap up

Creating New Views - Legends

Quick Access Toolbar

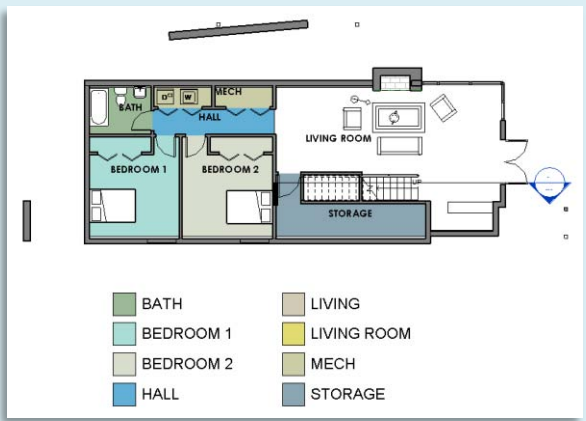
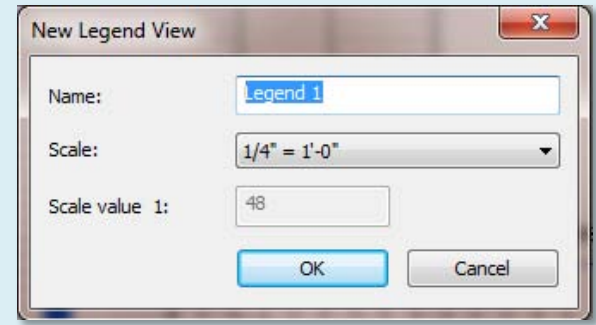
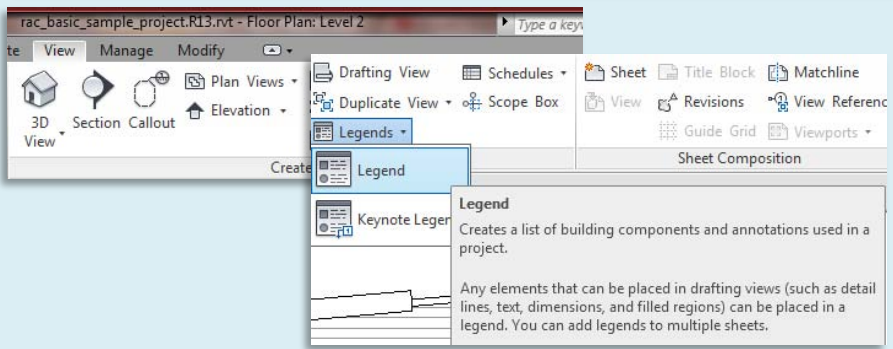
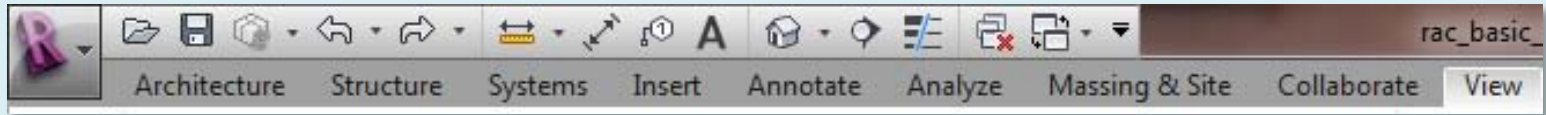

Creating New Views – Scope Box

Quick Access Toolbar

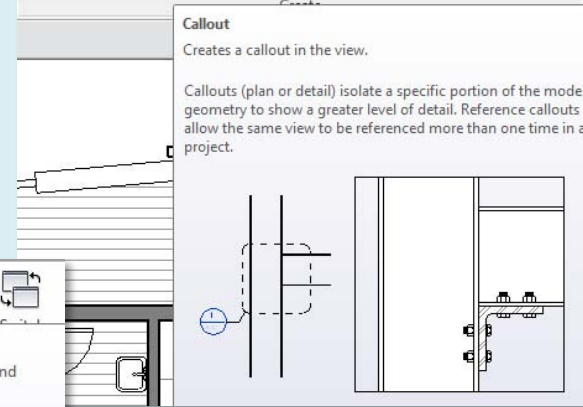
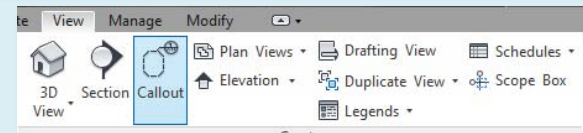
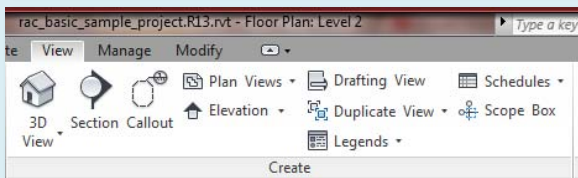
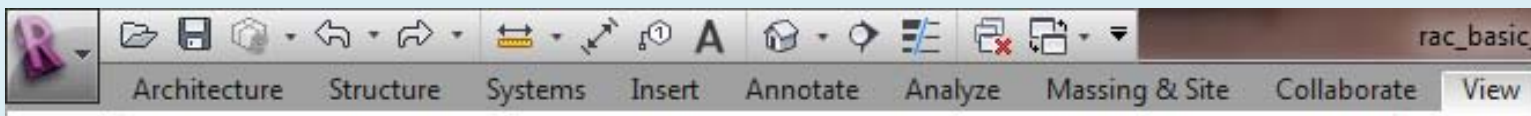

- **Controls the visibility of datum elements (grids, levels and reference lines) in specific views**

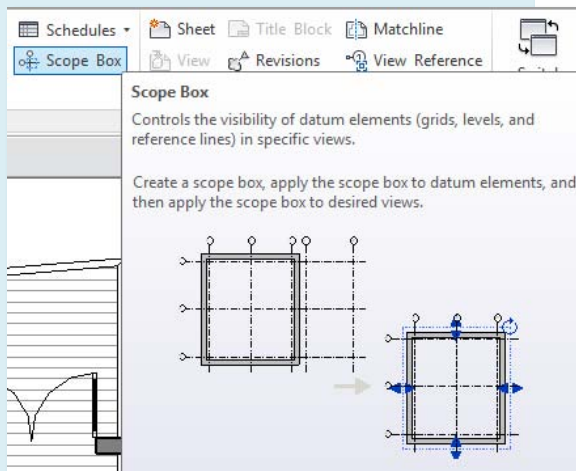

Day 01

Project Tour

- Change Units
- Take a Tour

Project Browser

- Floor Plans
- Ceiling Plans
- 3D Views
- Elevations
- Sections
- Renderings

Creating Views

- 3D Views
- Section
- Callout
- Plan Views
- Elevation
- Drafting view
- Duplicate
- Legends
- Schedules
- **Scope Box**

Orient to View

Scavenger Hunt

Sheet Layout

BIM & Parametrics

Wrap up

Orient to View

Quick Access Toolbar

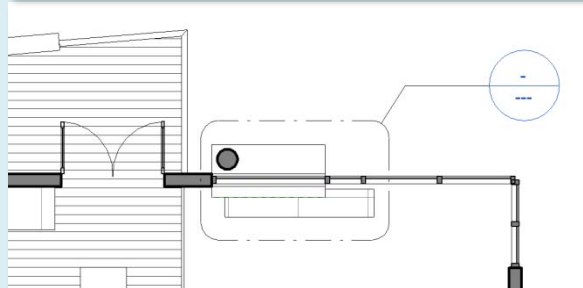
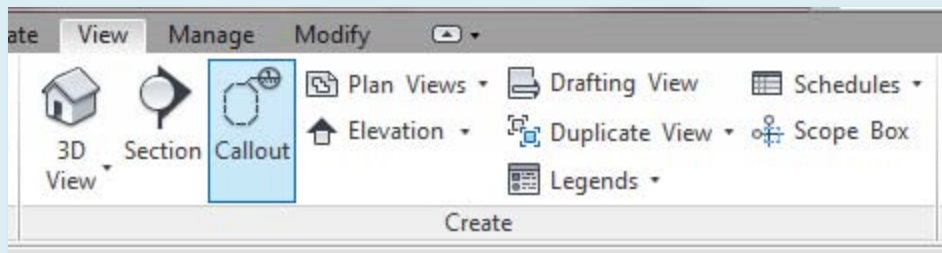

- **Create Callout**
- **Orient to View**
- **Home View**
- **Reveal Hidden**

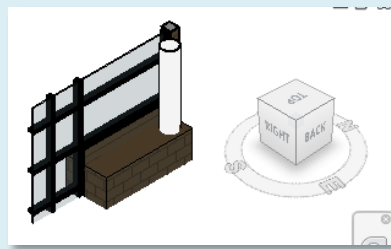
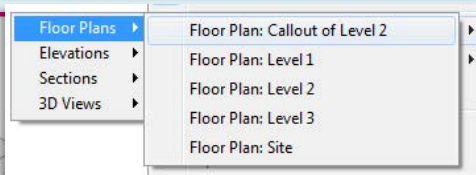
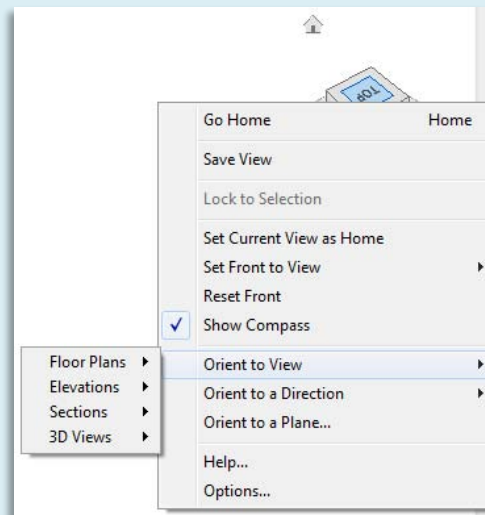
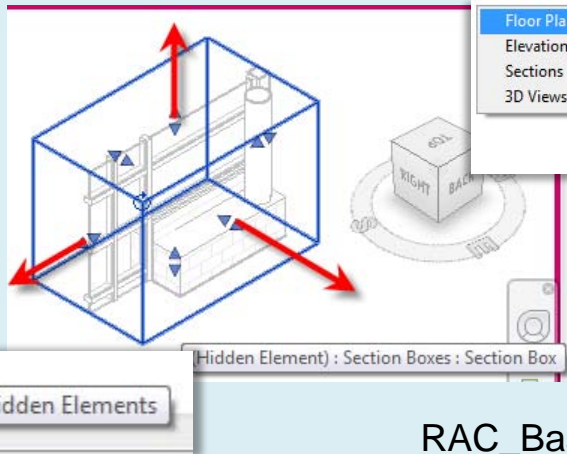

Day 01

Project Tour

- Change Units
- Take a Tour

Project Browser

- Floor Plans
- Ceiling Plans
- 3D Views
- Elevations
- Sections
- Renderings

Creating Views

- 3D Views
- Section
- Callout
- Plan Views
- Elevation
- Drafting view
- Duplicate
- Legends
- Schedules
- Scope Box

Orient to View

Scavenger Hunt

Sheet Layout

BIM & Parametrics

Wrap up

Day 01

Project Tour

- Change Units
- Take a Tour

Project Browser

- Floor Plans
- Ceiling Plans
- 3D Views
- Elevations
- Sections
- Renderings

Creating Views

- 3D Views
- Section
- Callout
- Plan Views
- Elevation
- Drafting view
- Duplicate
- Legends
- Schedules
- Scope Box

Orient to View

Scavenger Hunt

Sheet Layout

BIM & Parametrics

Wrap up

Revit Computers 3

Scavenger Hunt

RAC_Basic_Sample_Project.rvt

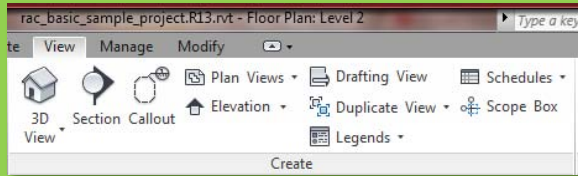

To describe the sample model identify and create as many unique views as you can find. (the scavenger hunt)

Group related views and place them on a sheet at the appropriate scale. A unique view is one that adds to the story and is not redundant.

Student Learning Objectives:

Upon successful completion of this assignment, the student will:

- Correctly Name a Revit File according to class standards
- "Tell a Story" through drawings by selecting appropriate views of a Revit Model.
- Logically group together related views and format these on a sheet in Revit.
- Understand the appropriate scale for various drawing types.

Assessment:

To evaluate the student's achievement of the learning objectives, the professor will do the following:

- Evaluate the file for proper naming convention.
- Evaluate the number of stories told by the student.
- Evaluate the quality and completeness of the story told by the student.
- Evaluate the quality and formatting of view laid out on sheets in Revit.
- Evaluate the appropriate use of scale.
- Assess assignment for deadline submission / lateness
- Commend the student for initiative beyond the given the assignment.

Day 01

- Project Tour
 - Change Units
 - Take a Tour

- Project Browser
 - Floor Plans
 - Ceiling Plans
 - 3D Views
 - Elevations
 - Sections
 - Renderings

- Creating Views
 - 3D Views
 - Section
 - Callout
 - Plan Views
 - Elevation
 - Drafting view
 - Duplicate
 - Legends
 - Schedules
 - Scope Box

- Orient to View
- Scavenger Hunt

Sheet Layout

- BIM & Parametrics

- Wrap up

Sheet Layout

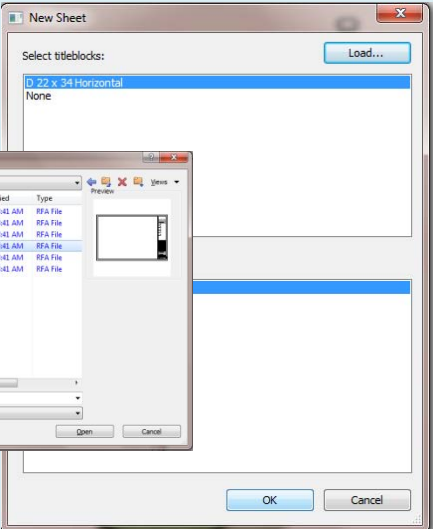
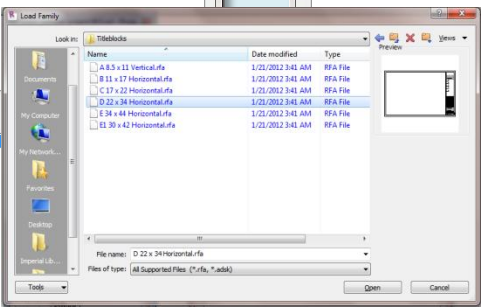
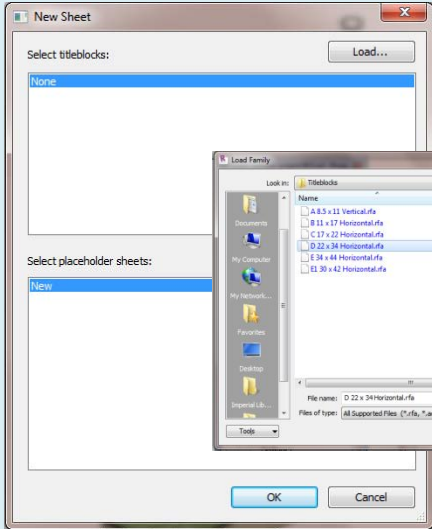
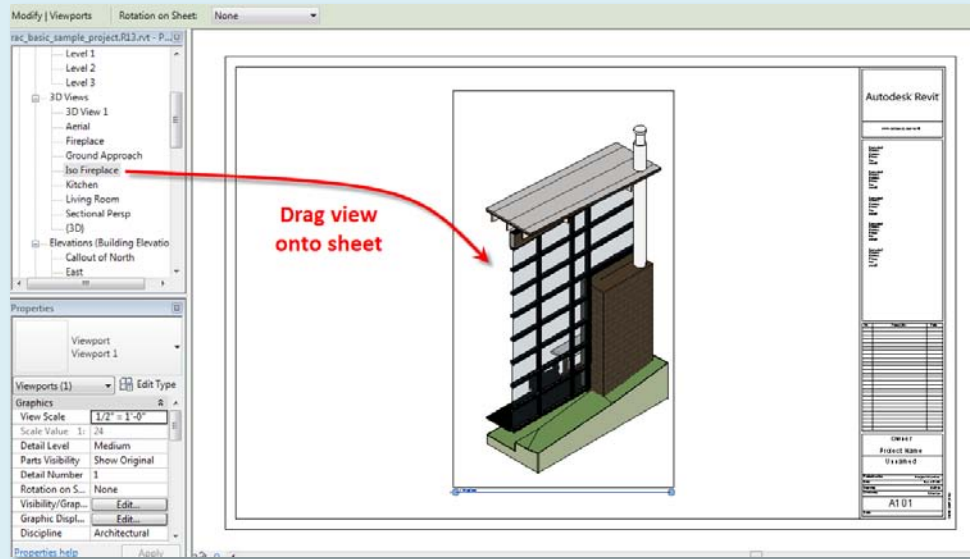
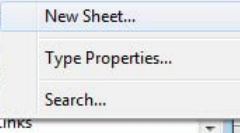
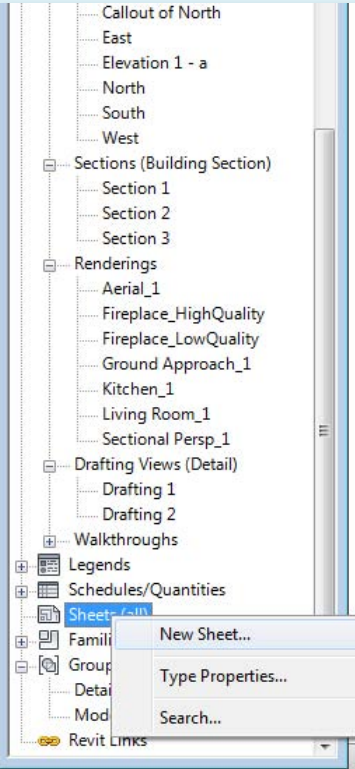
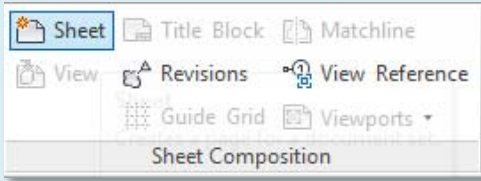

Day 01

- Project Tour
- Change Units
 - Take a Tour

- Project Browser
- Floor Plans
 - Ceiling Plans
 - 3D Views
 - Elevations
 - Sections
 - Renderings

- Creating Views
- 3D Views
 - Section
 - Callout
 - Plan Views
 - Elevation
 - Drafting view
 - Duplicate
 - Legends
 - Schedules
 - Scope Box

- Orient to View
- Scavenger Hunt
- Sheet Layout

BIM & Parametrics

Wrap up

Revit
Computers 3

Building Information Modeling (BIM) & Parametrics

Quick Access Toolbar

Door Schedule		
Mark	Level	Family and Type
	Level 2	Window_Insert: Window_Insert
	Level 2	Window_Insert: Window_Insert
2	Level 2	Single-Glass 1: 915 x 2134
3	Level 2	Single-Flush: 762 x 2134
4	Level 2	Double-Glass 1: 1800 x 2100
9	Level 2	Single-Flush: 762 x 2134
10	Level 2	Single-Flush: 915 x 2134
15	Level 2	Single-Flush: 915 x 2134

3d view,
plan view
and
schedule
view of
the same
door

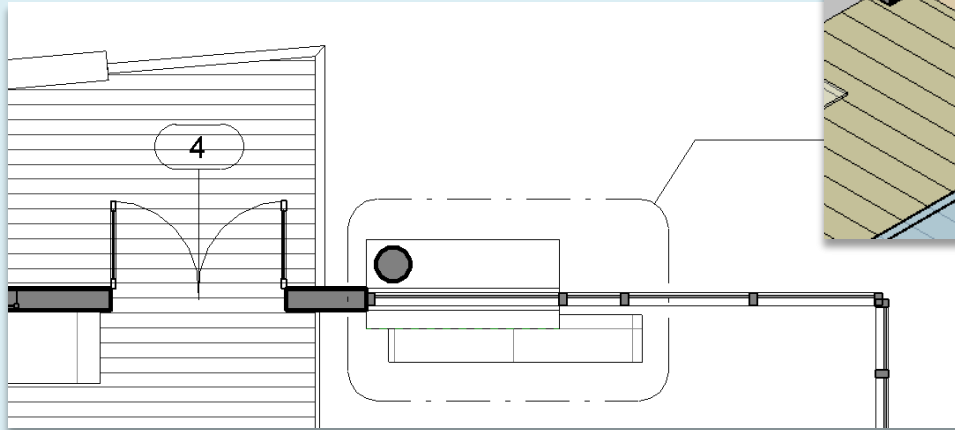

Day 01

Project Tour

- Change Units
- Take a Tour

Project Browser

- Floor Plans
- Ceiling Plans
- 3D Views
- Elevations
- Sections
- Renderings

Creating Views

- 3D Views
- Section
- Callout
- Plan Views
- Elevation
- Drafting view
- Duplicate
- Legends
- Schedules
- Scope Box

Orient to View

Scavenger Hunt

Sheet Layout

BIM & Parametrics

Wrap up

Revit
Computers 3

Day 1 – Wrap up

- **Units 1 = 1 foot**
- **Project Browser**
- **Object Properties**
- **Views**
- **Sheets**
- **Families**
- **Groups**
- **ZE = zoom extents**
- **Visual Styles**
- **Vocabulary terms**
 - **Parametric**
 - **Building Information Modeling**