

10/28/2014

JR CNC Router Table – (JR)², INC – Group #2

Innovative Computer Numeric
Control Machine operated by a
mechanical arm

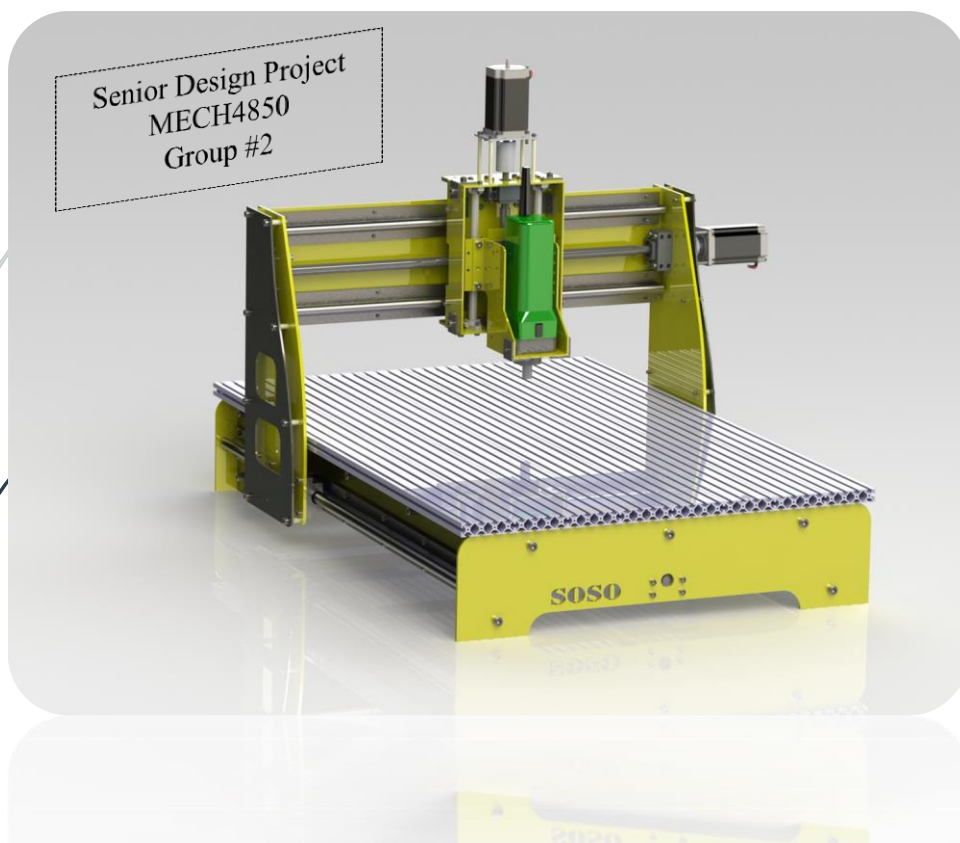



(JR)² CNC Router Table

Innovative Computer Numeric Control Machine operated by a mechanical arm

Contents

Chapter 1: Introduction.....	1
1.0 Design Goals	1
1.1 Problem Statement.....	1
1.2 Bench Marking	1
1.3 Identifying Customer Requirements and Needs	1
a) In-Use Purposes and Market	1
b) Functional Requirements.....	1
c) Other Requirements.....	1
d) Corporate constraints.....	1
e) Social, Political, and Legal Requirements	1
f) Evaluating Customer Requirements and Needs.....	1
1.4 Bench Marking	1
1.5 Energy Chart.....	1
1.5 Customer Need Matrix	1
1.6 Customer Need Importance (Ranking).....	1
Chapter 2: Proposal	1
2.0 Sketch	1
2.1 Description of the operation	1
2.2 List of materials and cost.....	1
2.3 Review of the marketing and technical assessment	1
2.4 Necessary key tasks to develop design.....	1
2.5 Timeline.....	1
2.6 Team Structure and Resource Management.....	1
2.7 List of Specifications	1
2.8 QFD (Quality Function Deployment)	1
2.9 Comments on the specifications	1
2.10 Data sources.....	1
Chapter 3: Detailed Product Design	1
3.1 Preliminary Sketch of Important Parts/Assemblies.....	1
a) Possible layouts of the product.....	1
3.2 Detailed Product Drawing	1
3.3 Motion Analysis	1



3.4 Assembly View 1

 a) Engineering Drawing of the Exploded Assembly View 1

 b) Bill of Material 1

Chapter 4: Manufacturing Plan 1

 4.1 Manufacturing Processes of Designed Parts 1

 4.2 Schedule 1



(JR)² CNC Router Table

Innovative Computer Numeric Control Machine operated by a mechanical arm

Tables/Figures

Figure 1.....	1
Figure 2.....	1
Figure 3.....	1
Figure 4.....	1
Figure 5.....	1
Figure 6.....	1
Figure 7.....	1
Matrix 1	1
Matrix 2	1
Matrix 3	1
Preliminary Sketch 1	1
Preliminary Sketch 2	1
Preliminary Sketch 3	1
Part Drawing 1.....	1
Part Drawing 2.....	1
Part Drawing 3.....	1
Part Drawing 4.....	1
Part Drawing 5.....	1
Part Drawing 6.....	1
Part Drawing 7.....	1
Part Drawing 8.....	1
Part Drawing 9.....	1
Assembly table	



Chapter 1: Introduction

1.0 Design Goals

The goal of this team's efforts is to develop a product that will establish *(JR)² Inc.* which hopes to revolutionize the market of such. Specifically, we were commissioned to design and manufacture a *CNC Router Table* that is both innovative and functional. The team will create numerous analyses, sketches, tests, surveys, customer need matrices and more so that one can be assured that to go on the right path. It is important to mention that this project rose after catching problems in the design and functionality of current CNC Tables existent on the market. This will be clarified with details and numbers, and will be also further explained. As a result, *(JR)² Inc.* plans to accomplish the most innovative CNC Router Table. What follows is a description of the product itself and information that helped the team to choose this specific project.

1.1 Problem Statement

After spending a long period of time researching and comparing the team's idea to the ones that are on the market, we immediately had the need to come up with solutions to certain problems encountered. One of the most significant and most drastic problem is the fact that an operator is restricted to the size (considering the width) of the material to be cut on the table. This is due to the design of such tables; which is built with symmetry. As a result, operators are restricted and obligated to use only the space that is provided by the table. The highly expensive price of such machines was another problem that was spotted. This one in specific is very significant due to the fact that it is not easily accessible to the targets; which are wood, aluminum and plastic enthusiasts, wood-workers, and so on.

1.2 Bench Marking

By measuring our product's ideas and comparing them to the competitors, we identified major differences that will be on our benefit. This is because of the act of addressing the problems found in such products. As a result, the team is very motivated to create a preliminary and innovative design and hopes to create a product that is both productive and aesthetically pleasant.

1.3 Identifying Customer Requirements and Needs

It is to be understood that customers are the lifeblood of every company. They are the main reason why products are developed in such form. The way the industry is set up, companies attempt to use the customer's need as much as possible; and as a result, they expect a profitable return. Before this, they'll need to identify and evaluate the customer requirements and needs. Hence, it was a necessity for the team to follow this procedure in order to mature our idea.

Numerous customer requirements and needs can be found for the market that is being targeted. To start, customers need to have the accessibility to purchase a quality and productive CNC Router Table. They are also in the need of the incorporation of new technology. Least but not last, customers need a more spacious table which can be used to cut larger piece of material without being restricted to the width of such.



1.3 (continuation)

a) In-Use Purposes and Market

The name of the product to be designed is “(JR)² CNC Router Table”. The function to be performed is to cut any desired type of shape or letter by the use of the famous Computer Numeric Control system. Although that is its main purpose, such machine will carry a tremendous amount of special features that will separate it from the existing ones. Such features are as follows:

- a) One retractable mechanical arm
- b) Perforated table top to debris to fall into the integrated dust collector
- c) Inexpensive
- d) Lightweight (usage of plastic and aluminum)
- e) Integrated vacuum and blower line at the tool bit
- f) Magnetized holder to store bits
- g) Multi-size jig for operation of various tools and bit sizes
 - a. I.e., Engraving, cutting, drawing, etc.
- h) LED light at the tool bit for better visibility
- i) Anti-Vibration rubber feet (isolators)

The intended market are wood, aluminum and plastic enthusiasts, wood-workers, technical drawers, industrial designers and more. The (JR)² CNC Router Table can be said to share only simple similarities to other companies' products. This is due to the impressive amount of special features that are incorporated into the machine. On the other hand, these special features do not increment the final retail price of the product by much. The estimated retail price for the (JR)² CNC Router Table is about \$2,500 dollars. This is a very reasonable price because if one compares this given price to the retail price of existent similar machines, one will see a huge difference which is why customers cannot purchase such machines.

b) Functional Requirements

- Usage of CAD Software to create the desired design and input it into the CNC Router
- Availability to cut larger pieces
- Fitment of a wide variety of cutters
- Suction of debris (top and bottom)

c) Other Requirements

- Teknic Servo Motors (for precise motion)
- MC901 Nylon for table frame
- 6061 Aluminum alloy posts for corners with threaded bottoms and perforated sheet for table
- Module 0.5 / injection molded Acetal gears
- Precision chrome steel shaft for guide rails
- End-support pillow block bearings for each lead screw
- Self-lubricating flanged bronze sleeve bushings for shafts
- Composite material for the arm structure and counter-weights



1.3 (continuation)

d) Corporate constraints

Due to the seriousness of the customer need to be able to purchase a CNC machine, the time to design, manufacture and do the marketing is very limited. In addition, there are manufacturing requirements that need to be followed in order to give a final product which will exhibit and ensure top quality. For example, the team needs to manufacture an aluminum table top which will be perforated around the whole area. Also, to manufacture and assembly the frame of the machine table can require a lot of time. But, due to the team's optimism and determination, we are more than sure that we will complete this project within two months. It is important to mention the financial aspect as well. We are constraint to an approximate of \$250 dollars which was donated to us in order to help the project get started. But, aside from this money, the team will collect money from each other in order to accomplish our goals. Also, since the team members work in the construction and gear production' area, it will be easy for us to bring any material at a very cheap price.

e) Social, Political, and Legal Requirements

It is to be understood that Social, Political, and Legal requirements are a very important aspect when designing or manufacturing a product. It plays a very important role, which should be taken care very seriously because the success of your company are dependent on a large scale to these requirements. Similar to every product that is on the market, (JR)² Inc. will follow every single regulation and requirements. This will help us be more protected and assure that we will not have any future issues pertaining to lawsuits and so on.

The team will make sure to complete all the legal requirements. We will post safety images on the machine that will be highly visible. In addition, we will supply our customers with an operation and safety manual in order to decrease the chance of injuries. Also, the (JR)² CNC Router Table will have a *one year warranty* and an unlimited time *24-hours* customer service.

f) Evaluating Customer Requirements and Needs

After spending a long period of time evaluating customer requirements and needs, the (JR)² Inc.' team is very enthusiastic to start the project and work towards the completion of such. It is very likely that one will see a very high profitable return due to this innovative idea and also because problems that were spotted during the research time are being addressed in the best possible form. Customer satisfaction is our priority and we won't rest until they appreciate our effort to make an easily accessible CNC Machine.



1.4 Bench Marking

The following chart shows a detailed comparison between current CNC router tables that are already on the market versus the (JR)² CNC Router.

Figure 1

Metric #	Needs	Imp.	NAME OF CNC ROUTER TABLES			
			Tourchmate 2x2™	Shapeoko 2	Shortcut 203	JR CNC Router
1	Portability	4	100 lbs	260 lbs	390 lbs	Aprox. 300 lbs
2	Easy Maintance	4	yes	yes	no	yes
3	Sturdy	5	Steel frame	Anneal Steel frame	Steel	Aluminum
4	Compact	4	2ft x 2ft	550mm x 510mm	42" x 48"	2' x 2'
5	Affordability	5	\$400	\$650	\$720	\$500
6	Peformance	5	269 oz motor	Nema 17 62 oz/in	0-300 IPM	Unknown
7	Easy to Control	5	Relay switch	Grbl installed	MACH controller	Controller
8	Axises	4	2(x) axis driver, 1(y)	3 axis Arduino based	x, y, z tolerance of ± .002	3 axis robotic arm
9	Cutting Area	3		298mm x 301 mm x 54mm	24" x 36" x 6"	40" x 40"
10	Use of Simple cutters	3	close circuit tools	1/8" tool size	Unknown	mutiple tool cutter
11	Assembly	5	Simple	Pre assemble	Complex	Simple
12	Availability of parts	4	Online only	Online only	Online only	Online only
13	Minimal scrap	2	yes	yes	yes	yes
14	Compatability	4	great	limited cutting tool sizes	cutting tools from website	mutiple tool cutter

1.5 Energy Chart

The following chart shows the numerous sources of energy that can be used to power the machine.

Figure 2

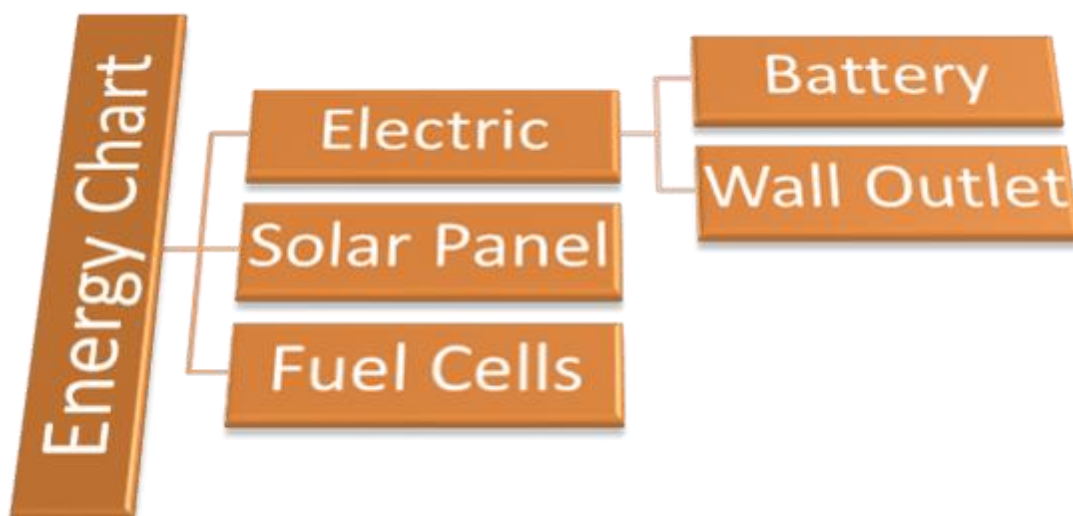



1.5 Customer Need Matrix

The following chart shows a *Customer Need Matrix* which is one of the most important steps in the design process. By doing so, one can increase the chance to obtain an effective solution. Other than helping understand the problem thoroughly, it also determines whether the product will sell or not.

Matrix 1

(JR)^2 Router Table		Metric	Lightweight	Easy to change parts	Aluminum frame	2ft * 2ft	<1000	High quality	Software guided	Robotic arm	Dependency on the tool	Adjustable bracket	Easy instructions	Instock online order	Attachment for vacuum	Fits variety of cutters	
		NEEDS															
1	Portability		★	★	★	★											
2	Easy Maintenance												★	★			
3	Sturdy				★												
4	Compactable		★			★							★				
5	Affordability						★							★			
6	Performance									★							★
7	Easy to Control								★	★	★						
8	3 axes								★	★							
9	Fast Cutting Rate										★						★
10	Use of simple cutters											★					★
11	Simple assembly		★	★		★							★				
12	Availability of parts			★			★					★		★			★
13	Minimal scrap														★		
14	Compatibility			★			★			★	★	★	★	★			

1.6 Customer Need Importance (Ranking)

Matrix 2

No.	Product Name	NEEDS	Importance
1	(JR)^2 CNC Router table	Portability	3
2		Easy Maintenance	4
3		Sturdy	5
4		Compactable	4
5		Affordability	5
6		Performance	5
7		Easy to Control	5
8		3 axes	4
9		Fast Cutting Rate	3
10		Use of simple cutters	3
11		Simple assembly	5
12		Availability of parts	4
13		Minimal scrap	2
14		Compatibility	4

Matrix 3

Metric No.	NEEDS #	Metrics	Importance
1	1,4,11	Lightweight	3
2	2, 11,12,14	Easy to change parts	4
3	1,3	Aluminum frame	5
4	1,4,11	2ft* 2ft	4
5	5,12,14	< \$1000	5
6	6,7,8,9,14	High quality	5
7	7,8	Software guided	5
8	6,7,8,14	Robotic arm	4
9	7,9,14	Dependency on the tool	3
10	10,12,14	Adjustable bracket	3
11	2,4,11,14	Easy instructions	5
12	2,5,12,14	Instock order online	4
13	13	Attachment for vacuum	2
14	6,9,10,12	Fits wide variety of cutters	4



JR CNC Router Table – (JR)², INC – Group #2

10/28/2014

Innovative Computer Numeric
Control Machine operated by a
mechanical arm

Chapter 2

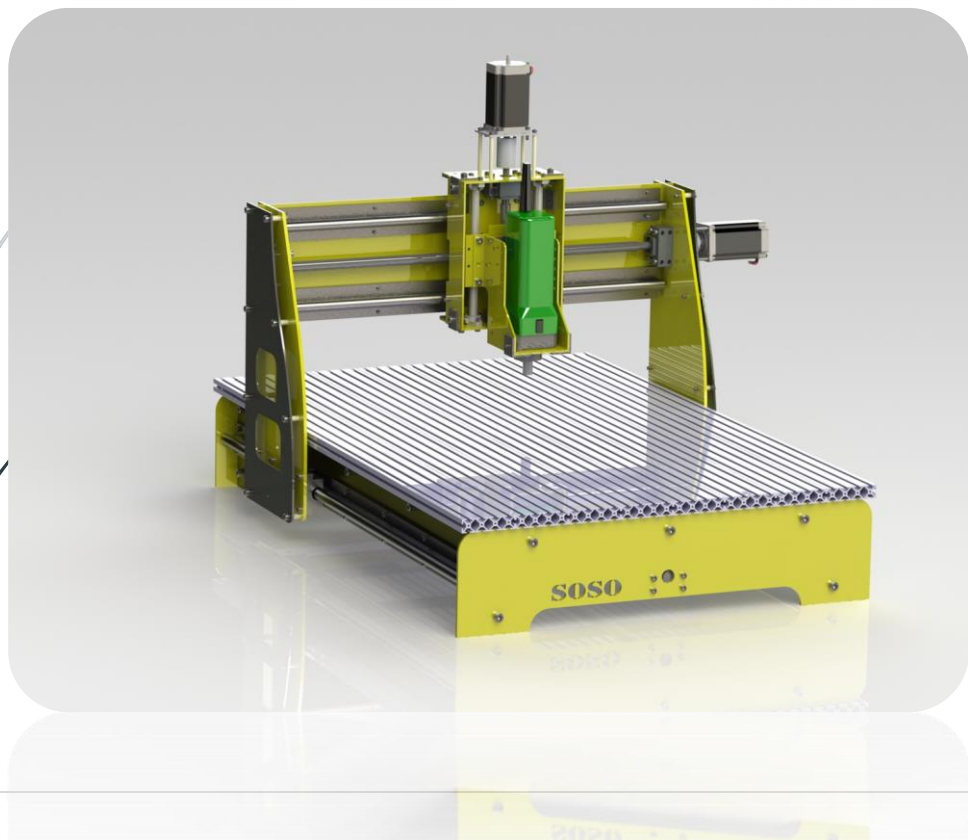



Chapter 2: Proposal

The following image is a sketch of the (JR)² CNC Router Table
Figure 3

2.0 Sketch

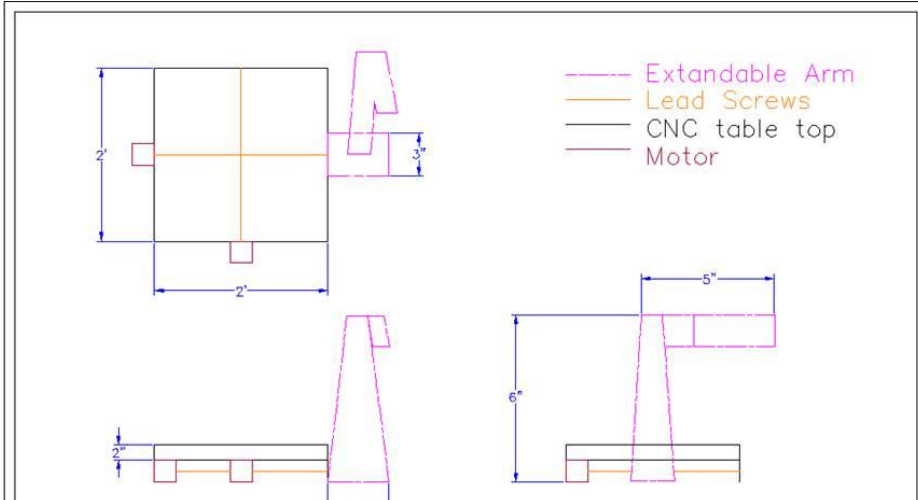

NEW YORK CITY COLLEGE OF TECHNOLOGY Senior Project 300 JAY STREET BROOKLYN NEW YORK 11206		SCALE 1:10
ALL DIMENSIONS ARE IN INCHES		
TITLE JR CNC Table		REV.
PROJECT STAGE Preliminary Design		
GROUP MEMBERS Ronald, Josel, Raymond & Jeffrey		

2.1 Description of the operation

The (JR)² CNC Router Table will operate using a 120v line but the function of such will be outstanding. By using this innovative router table, one will be able to perform cut, engrave or even draw any desired shape or letter in the most accurate and simplistic way; which is by the use of the famous Computer Numeric Control system.

2.2 List of materials and cost

Table 1

PRODUCT PRICE LIST

Product list to be used in order to create the JR CNC Router Table

UNITS	NAME	Description	PRICE/UNIT	TOTAL
3	Motors	For the table	\$30.00	\$90.00
1	Shaft	6" shaft	\$20.00	\$20.00
4	Spur gear		\$30.00	\$120.00
1	Joint	For arm	\$15.00	\$15.00
4'x4'	Aluminum table	Perforated	\$50.00	\$50.00
1	Vacuum/Blower motor		\$30.00	\$30.00
2	Plastic lines	For vacuum and blower	\$10.00	\$20.00
2	Fine pitch lead screws		\$20.00	\$40.00
2	Pillow block bearing	End type	\$10.00	\$20.00
1	Magnet	For holding tool bits	\$10.00	\$10.00
1	Swtich	Illuminated switch	\$15.00	\$15.00
4	Rubber feet	Anti-vibration	\$15.00	\$60.00
1	LED Bulb	Small	\$15.00	\$15.00
1	Plastic container	For debris collection	\$15.00	\$15.00
1	Pack of wires	For electrical components	\$35.00	\$35.00
			Total	\$555.00



2.3 Review of the marketing and technical assessment

Before the team came into an agreement to proceed with this prestigious project, a lot of research and analysis was done. A summary of such analyses are as follows:

- **Market Analysis:** Due to the fact that these machines are a one-time-buy only, the complexity of creating one and how recent they are, they are priced very high. As a result, companies that design and manufacture this machines, tend not to sell a lot of them. On the other hand, there are a lot of people who would like to buy one but cannot afford it. Therefore, the team decided to make an inexpensive one but yet one that makes a difference.
- **Specifications:** CNC Router tables are able to handle various routers with different HP (horse power); but this depends on the structure of such and in the motors that are used. But, the most common router HP that a CNC Machine can take is approximately *3.5HP* which has the ability to do a very outstanding performance.
- **Functional Analysis:** The functionality of the existent CNC Router table meet the requirements but lack of a very important factor which is space. Operators with such Router tables are limited to the size of the materials to cut due to how the machine is built.

2.4 Necessary key tasks to develop design

The process of developing the design of the *(JR)² CNC Router Table* was a bit challenging and time consuming. Similar to any other concept or existing product, our design was inspired by comparing it to other designs and trying to give it a different approach. It is to be acknowledged that our experiences, passion, creativity and intelligence influenced a lot as well. We created many sketches with the intention to evaluate them to pick one or mix the possible winners. Throughout this process, the team encountered some barriers that needed to be faced in the most positive way and attempt to overcome them. For example, the fact that the structure of every CNC Router Table in the market was built in similar ways affected us by doubting if our concept will work or not. Also, the team acknowledged that a very challenging part to be faced was the programming part; since none of us have experience in that field. Least but not last, a necessary key task that helped to develop the design was by thinking about customer needs. This helped in a tremendous way and because of this, we incorporated special features on the *(JR)² CNC Router Table* in order to address the customer needs.



2.5 Timeline

- Week 1-3: Sketch and design of the CNC router table

Create a list of parts needed with its cost. Then breakdown each part of the CNC router into components of design (arm, base, table, etc.) for calculations and refinement. During this time, the group will come up with an ideal of the model to make and create a close sketch to what is expected. Furthermore, the team will make changes to the ideal to better suit customer needs as well as making it practical and doable.

- Week 4-5: Calculations and refining the design of the CNC router

During these two weeks, the group will take each component of the CNC router and run simulation testes on the components to make sure everything is safe and functional to be incorporated into the design of our CNC router. Once each part passes the tests, the group will then continue with the refinement of the design to produce our final sketch and design of the project.

- Week 6-7: Construct the Base for the CNC router

It will take the group approximately two weeks to put the base of the CNC table together. Also, it will give us a chance to make any necessary adjustments to the design or base if needed

- Week 8-11: Assembly of the Mechanical Arm and testing motors

Three weeks will be spent on assembling the mechanical arm and making sure each motor works for the specific direction it should travel in. This is a vital part of our CNC router, so testing and adjusting is critical during these weeks.

- Week 12-14: Computer programming

Our group will have to use the remaining few weeks to write the programming codes for the CNC router. It's a very tedious task but crucial since the codes are the brains of our CNC router; which is responsible for carrying out the commands that are inputted into the computer.

- Week 15: Final Presentation

If all goes well, the team should be able to present the finish product to the class. The final design (CAD) and the physical assembly should be presented along with a final report.



2.6 Team Structure and Resource Management

The team came into an agreement to work together towards the completion of the project. As a result, the structure of the team is very simplistic. It is one where there is no “overhead”. All members of the team (*Ronald, Jeffrey, Josel and Raymond*) are committed and responsible to collaborate and help each other out as much as possible. By doing so, the necessary steps and/or tasks that need to be done will be done in a much faster and easier form.

Figure 4

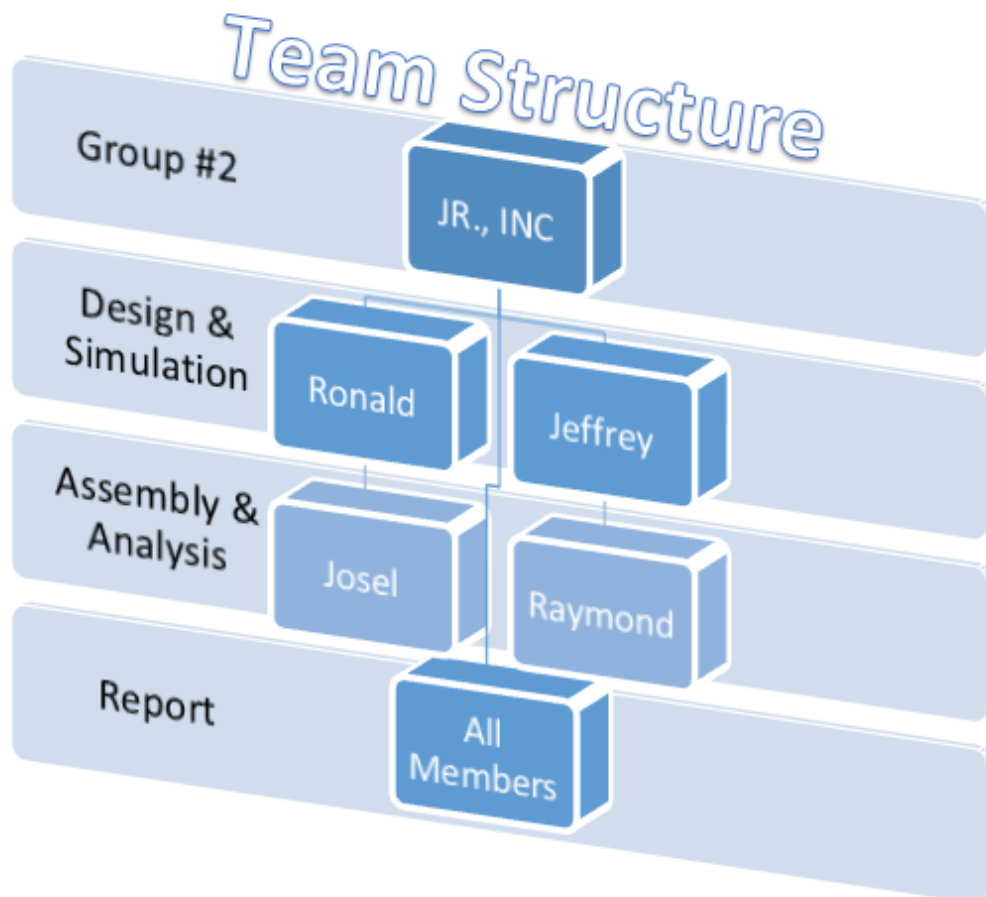

2.7 List of Specifications

The following are information and approximations of the dimensions that will be found on the *JR CNC Router Table*;

- Size of table: 22” x 22”
- Thickness: 3 inches.
- Overall weight: 20lbs
- Shape: Square
- Surface finish: Anodized aluminum coating or powder coated
- Cutting Area: 18 ½” x 18 ½”
- Power: Electricity: Wall Outlet (120 V)
- Function: Ability to use numerous cutting tools to perform any desired cut which can be designed using CAD Softwares.



2.8 QFD (Quality Function Deployment)

Figure 5

House of quality template and benefits

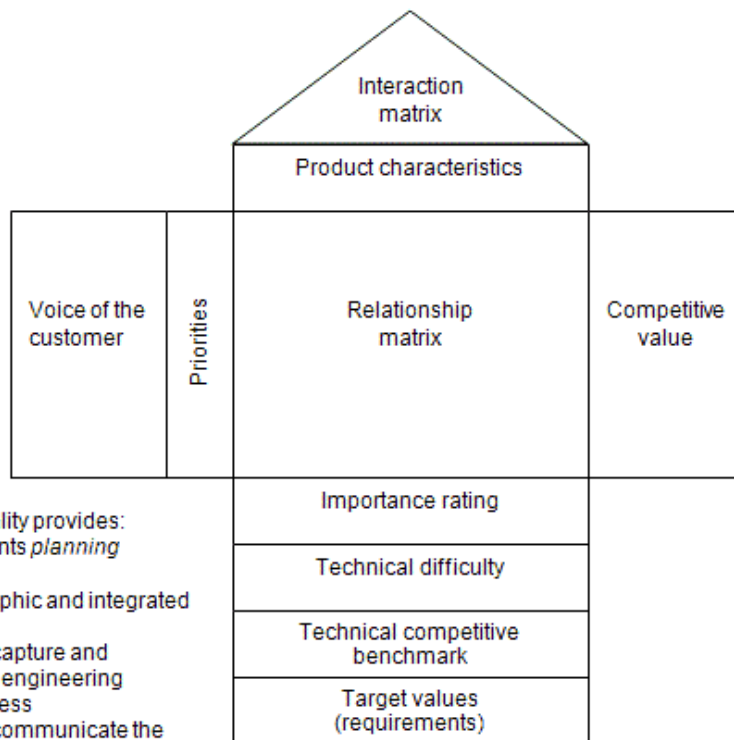

The house of quality provides:

- A requirements *planning* capability
- A tool for graphic and integrated thinking
- A means to capture and preserve the engineering thought process
- A means to communicate the thought process to new members of the QFD team
- A means to inform management regarding inconsistencies between requirements, risks, and needs of the customer

2.9 Comments on the specifications

Specifications that will need more development will be announced as soon as we start building the physical model

2.10 Data sources

- “Burn Tables” – Link: <http://burntables.com/cnc-router-table/>
- “Instructables” – Link: <http://www.instructables.com/id/Building-a-CNC-router/>
- “CNC Router Parts” – Link: <http://www.cncrouterparts.com/>
- “BuildYourCNC” – Link: <https://www.buildyourcnc.com/>



10/28/2014

JR CNC Router Table – (JR)², INC – Group #2

Innovative Computer Numeric
Control Machine operated by a
mechanical arm

Chapter 3

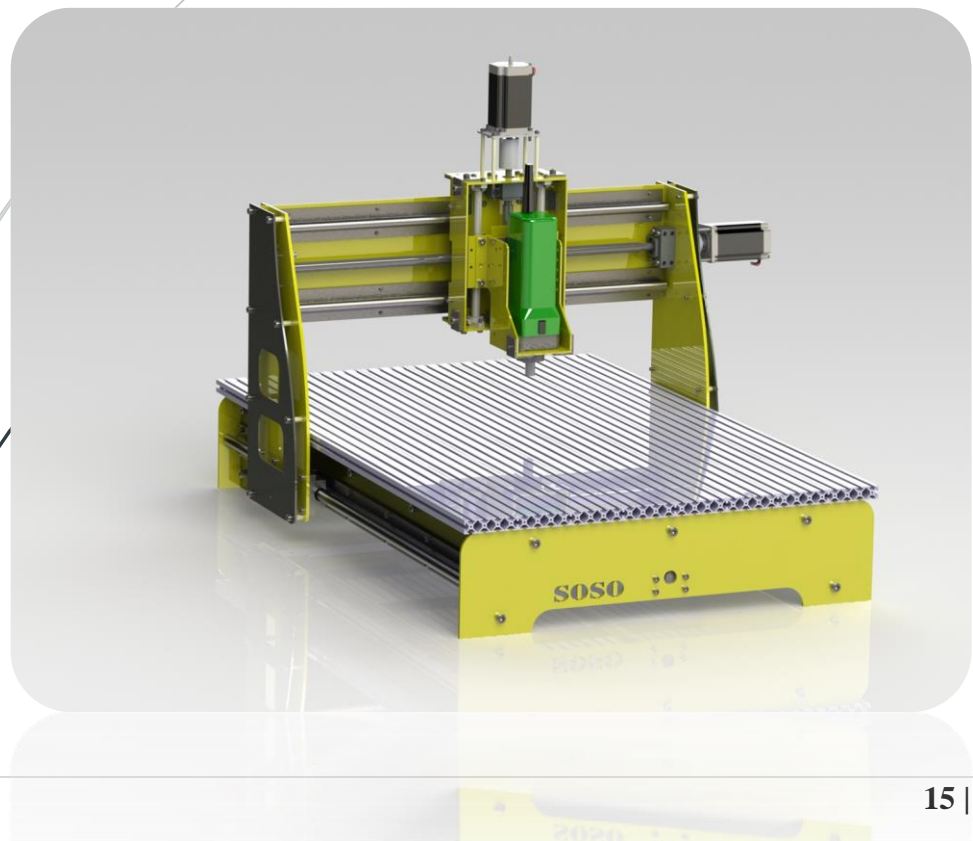



Chapter 3: Detailed Product Design

This chapter includes important information of the functionality of the product, a kinematics analysis of the motions that the Router table will exhibit, detailed engineering drawings, and more.

Figure 6

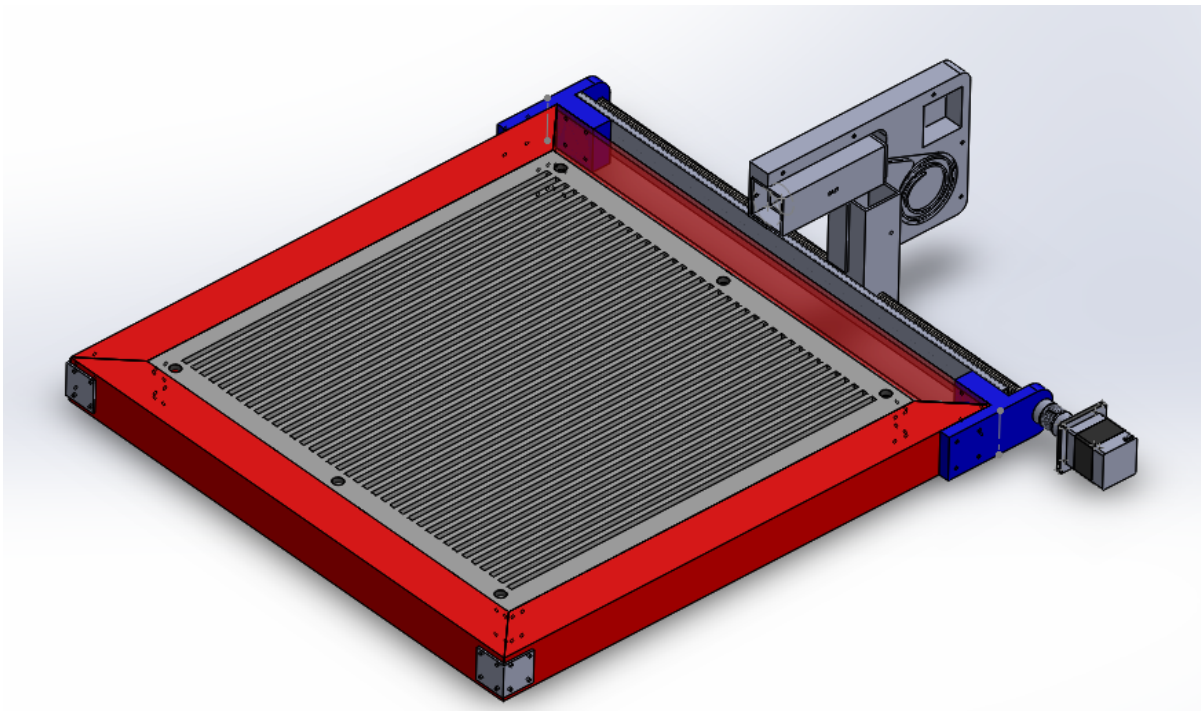

3.1 Preliminary Sketch of Important Parts/Assemblies

(JR)² Inc. had numerous ideas on the creation of the most important parts of the Router Table which as a result, it could increase the aesthetic of the product. On the other hand, such ideas were found not to be appropriate or functional for various reasons. Therefore, the team decided to prioritize and meet the functional requirements first before thinking about the aesthetic aspect. As a result, the components above were designed in a way that together after doing the assembly, they will all share a common task; which is functionality. Therefore, motion analysis and finite element analysis needed to be done. The result of such analyses will be shown on the following pages.

- NOTE: Durability, ease of use and ability to manufacture were also taken into consideration before designing the components.

The following images show the most important functional components of the (JR)² CNC Router Table which were carefully designed with the use of two powerful CAD Software; that go by the name of Autodesk AutoCad and Solidworks.



3.1 (Continuation)
Preliminary Sketch of Important Parts/Assemblies

Preliminary Sketch 1

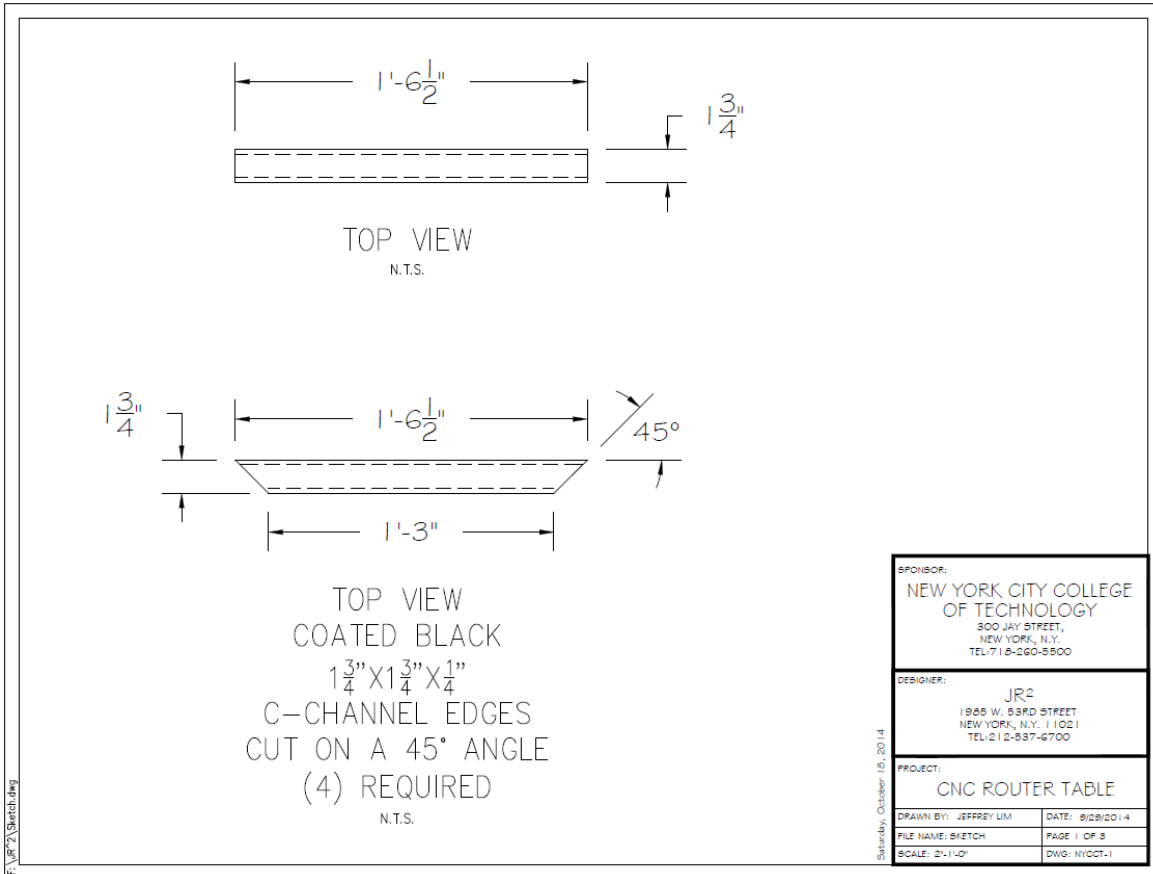

Preliminary Sketch 2

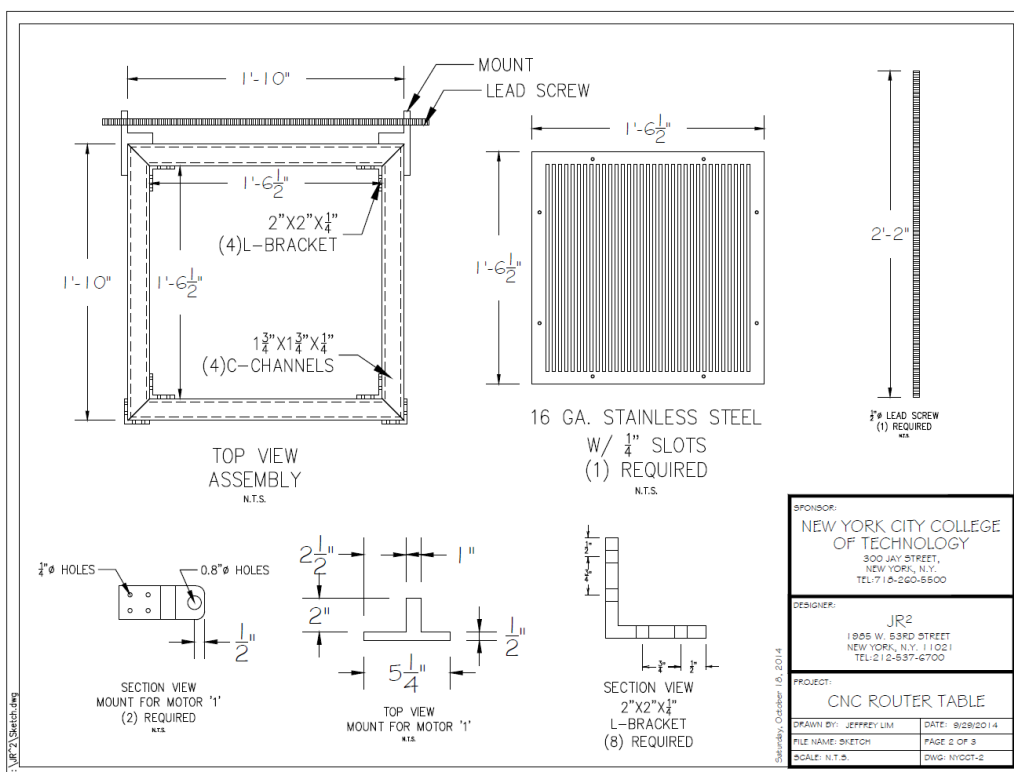



3.1 (Continuation) Preliminary Sketch of Important Parts/Assemblies

Preliminary Sketch 3

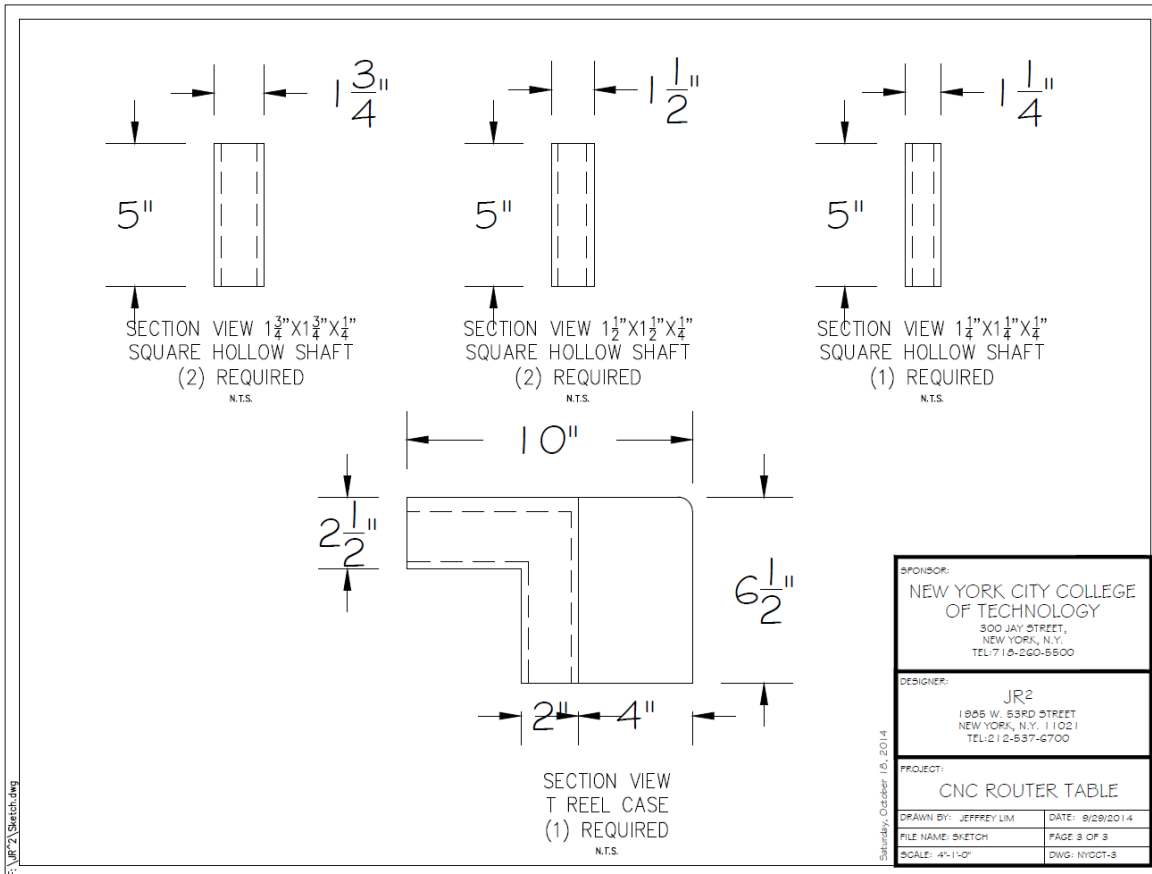

The images above are preliminary sketches of the parts that are considered to be the most important of the product. The functional requirements established are met by the use of these components/parts for the following reasons:

- ✚ Coated Black C-Channel ($1\frac{3}{4}'' \times 1\frac{3}{4}'' \times \frac{1}{4}''$)
This particular piece is made out of Aluminum; hence it helps us keep the CNC Router as lightweight as possible. Also, it is a hollow piece with only $\frac{1}{4}''$ of body thickness which also makes it lightweight, compared to a solid shaft.
- ✚ Stainless Steel Top Plate ($18\frac{1}{2}'' \times 18\frac{1}{2}'' \times 16\text{ga.}$)
 The top plate is a cut-out of Stainless Steel (*type 304*) which is resistant to corrosion, heat damage and chemical damage. The following are top advantages that Stainless steel gives:

 - Aesthetically pleasant
 - Long life span
 - Easy to clean and maintain
 - High strength
- ✚ Mount for Motor
 The material chosen for this piece is ABS which stands for *Acrylonitrile Butadiene Styrene*. The properties encountered in this polymer are one of the best in its category; it is very durable and strong.



3.1 (Continuation)

Preliminary Sketch of Important Parts/Assemblies

✚ L-Bracket (2" x 2" 1/4")

The material chosen for the *L-Bracket* is Stainless Steel (*type 304*) which is appropriate and helps the team meet the functional requirements. The Stainless Steel provides high strength which results in long-life span and it is also aesthetically pleasant which in this case it is very important since these L-Brackets will be visible.

✚ Square Hollow Shafts

The Square Hollow Shafts are made out of aluminum. This helps the CNC Router Table Robot Arm to be lightweight; which is a very important requirement to (JR)² Inc.

✚ T Reel Case

The *T-Reel Case* is a custom part that helps with the incorporation of the flex-rack and the tension cable. The material chosen is *PC_ABS Plastic* which is strong enough to sustain any forces.

a) Possible layouts of the product

The team had a general idea of the layouts of the (JR)² CNC Router Table but as time went by, numerous changes were made in order to meet the functional requirements that were set. At first, the team considered a 2' x 2' table which was then shortened to 18 1/2" x 18 1/2" due to dimensioning constraints caused by the Robotic Arm Shafts which couldn't be extended to 24in. Secondly, (JR)² Inc., had the idea to follow the trend and use the most common design in order to minimize errors. But, after running analysis and research, the team realized that changes in the design needed to be made. These changes resulted in having a robotic arm on one side of the table instead of a two guided rail shafts which are found in existent CNC Router Tables. This helps an operator to cut materials that are larger and wider due to not having a size constraint anymore. Thirdly, the team planned to create a product as lightweight as possible and use ABS Plastic to help obtain the desired results. Unfortunately, this couldn't become true due to the fact that *ABS Plastic* is not strong enough to hold the material weight in the cutting area (*top plate*) and it is also not durable. As a result, the team desired to work using Aluminum and stainless steel. Another important change is one that wasn't expected. The team decided to go beyond and build a system that has the ability to create cuts in 3 Axis. At first, the CNC Router Table was meant to only have two degrees of freedom. Another change was made during the analysis of possible layouts. This change involves the change of functional parts such as the gear and the motors. Furthermore, the team decided to use flex-rack instead of gears because it was the best possible way to extend the Robotic Arm Shaft. This decision was made by the use of our design matrix.



3.2 Detailed Product Drawing

The following images are the Part Drawings (engineering drawings) of the most innovative router table ever made. These drawings were created with the use of Solidworks.

- NOTE: The engineering drawings include the material to be used and all the necessary information for fabrication.

Part Drawing 1

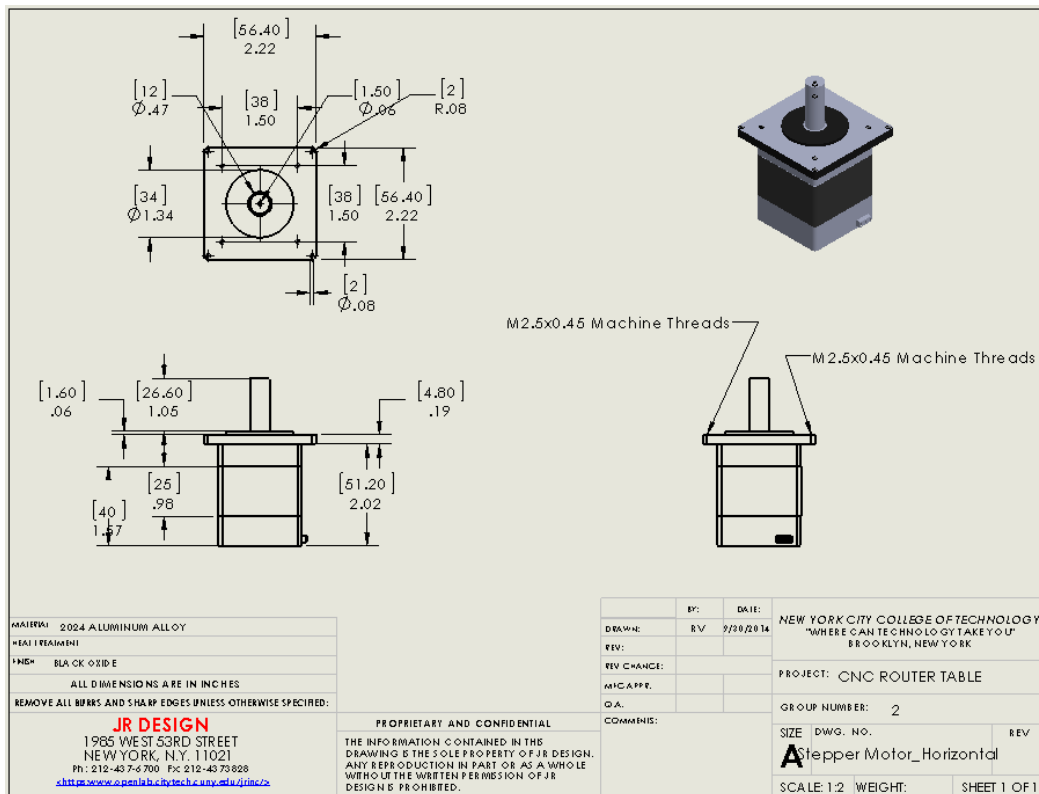

Part Drawing 2

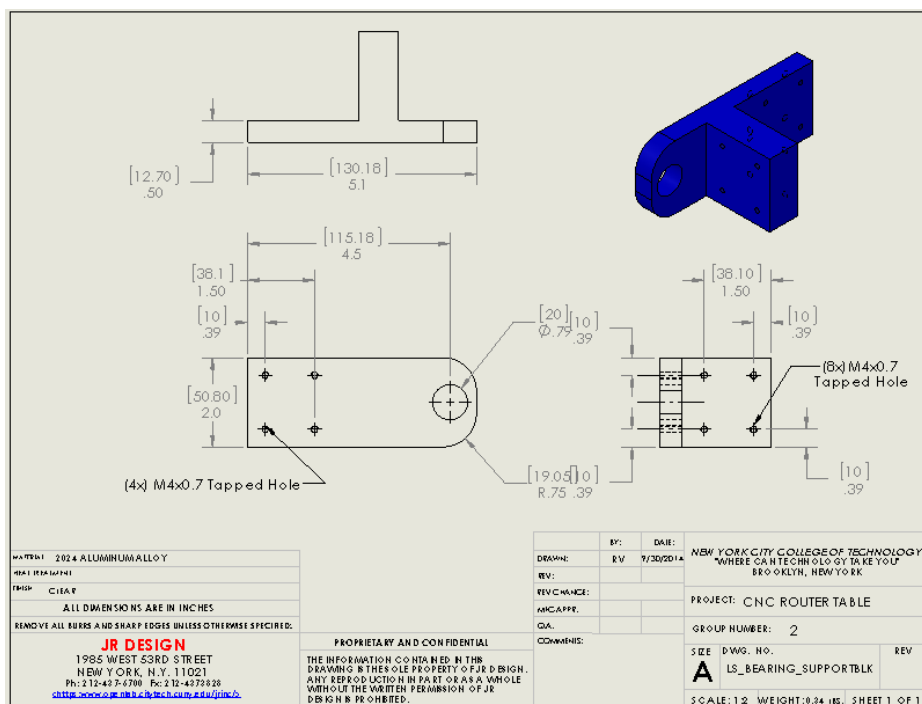



3.2 Continuation
Detailed Product Drawing

Part Drawing 3

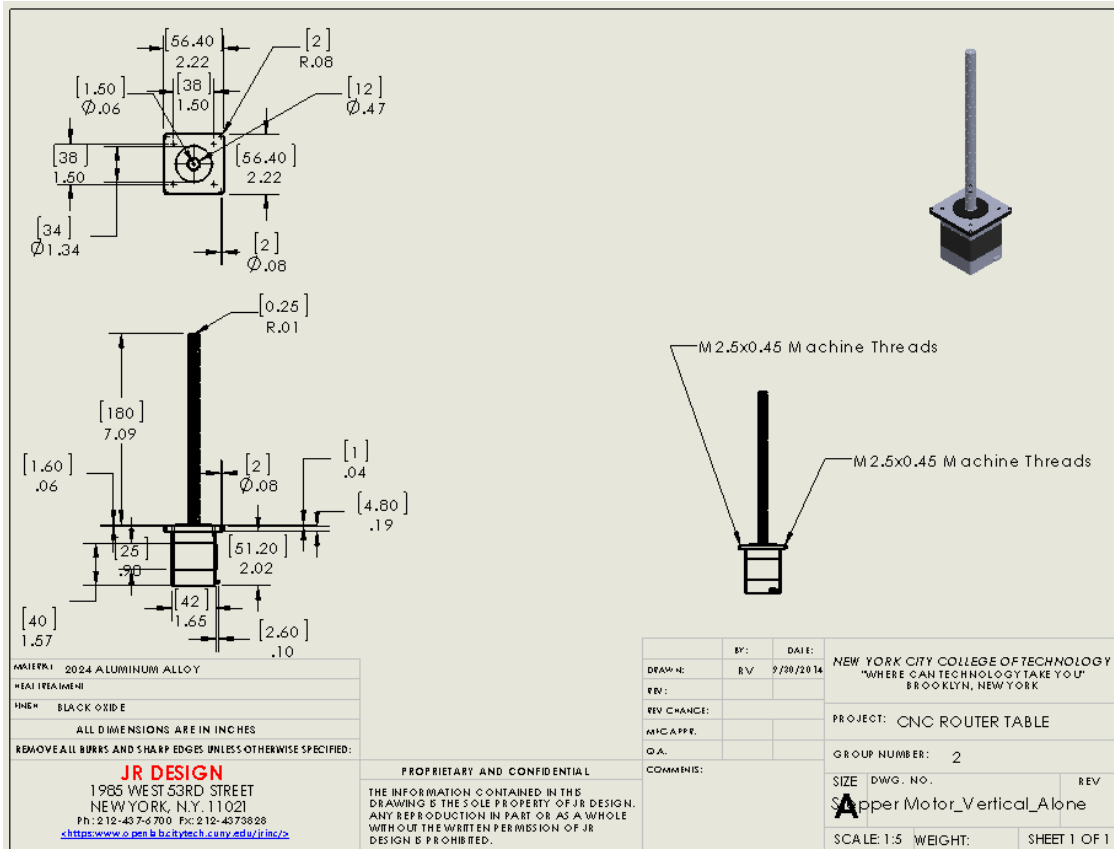

Part Drawing 4

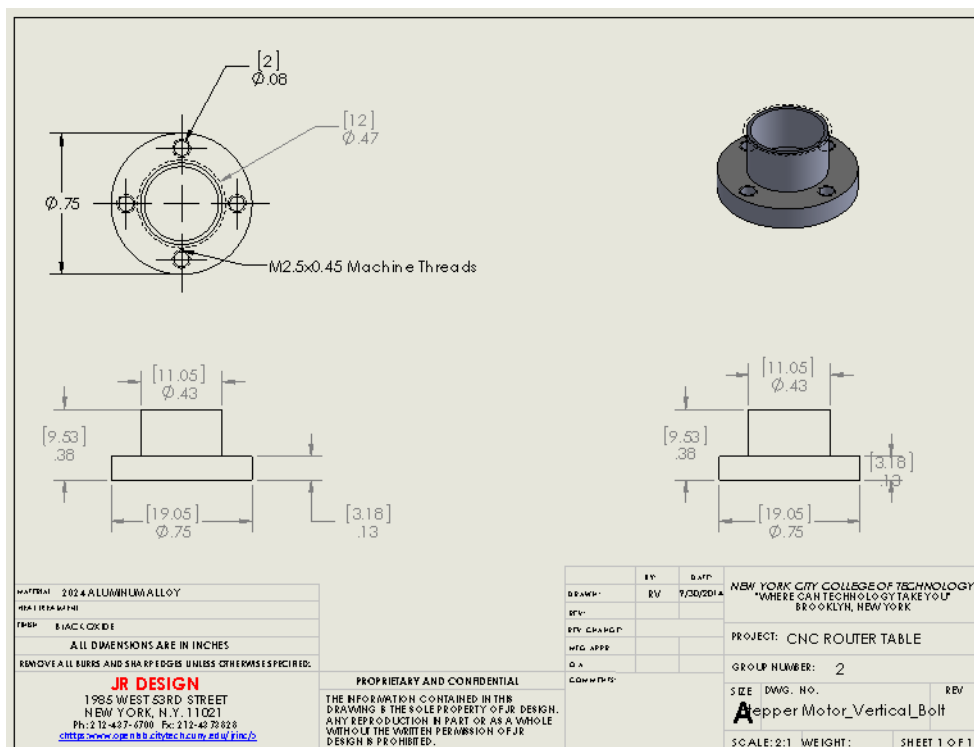



3.2 Continuation
Detailed Product Drawing

Part Drawing 5

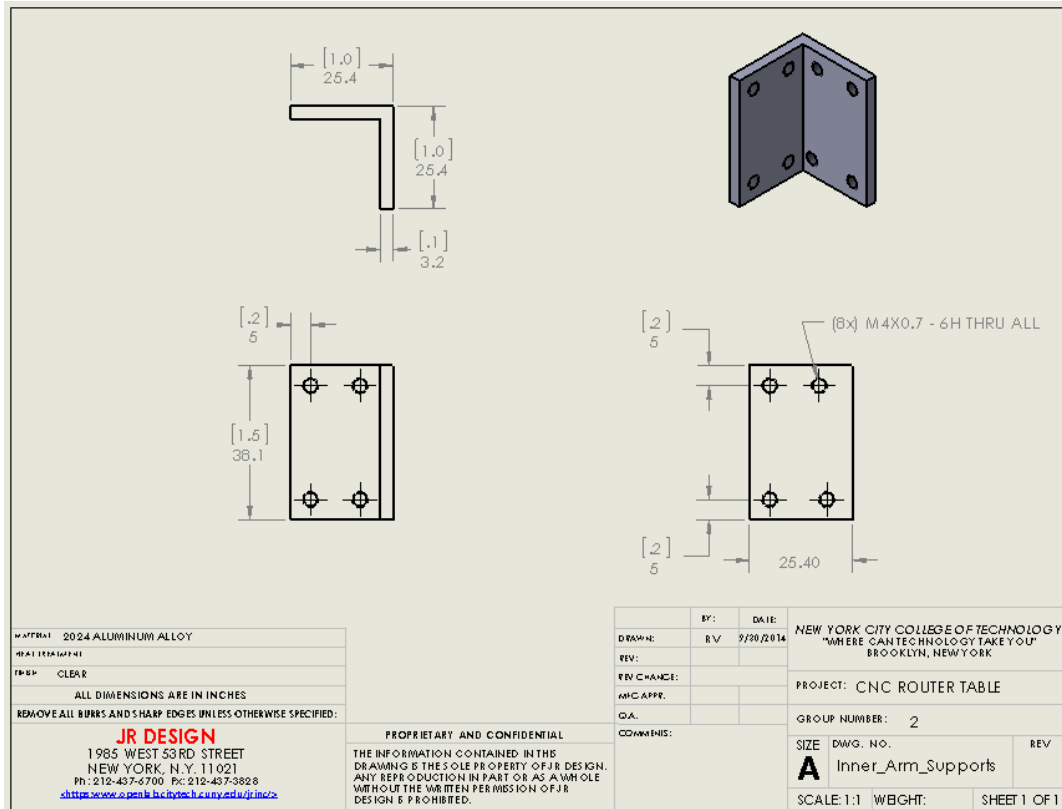

Part Drawing 6

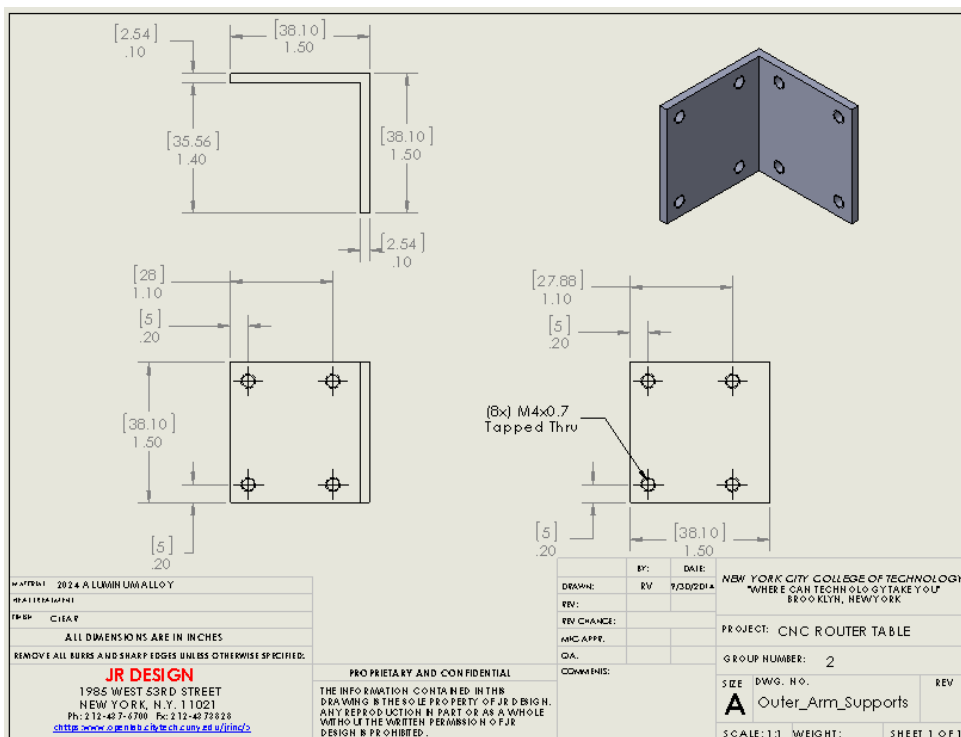



3.2 Continuation
Detailed Product Drawing

Part Drawing 7

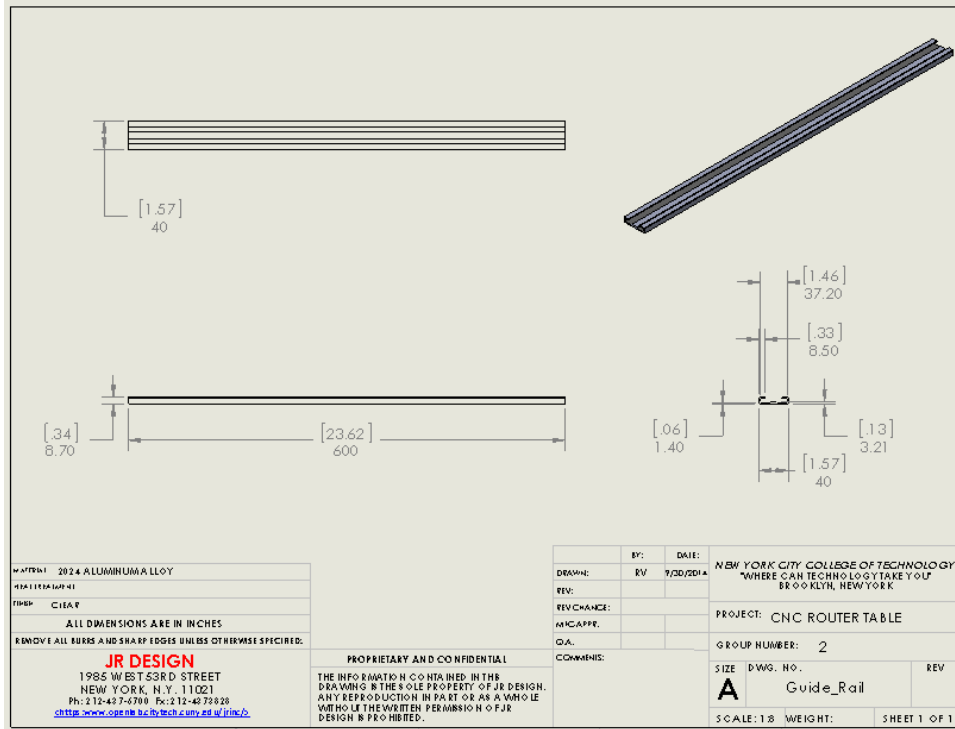

Part Drawing 8

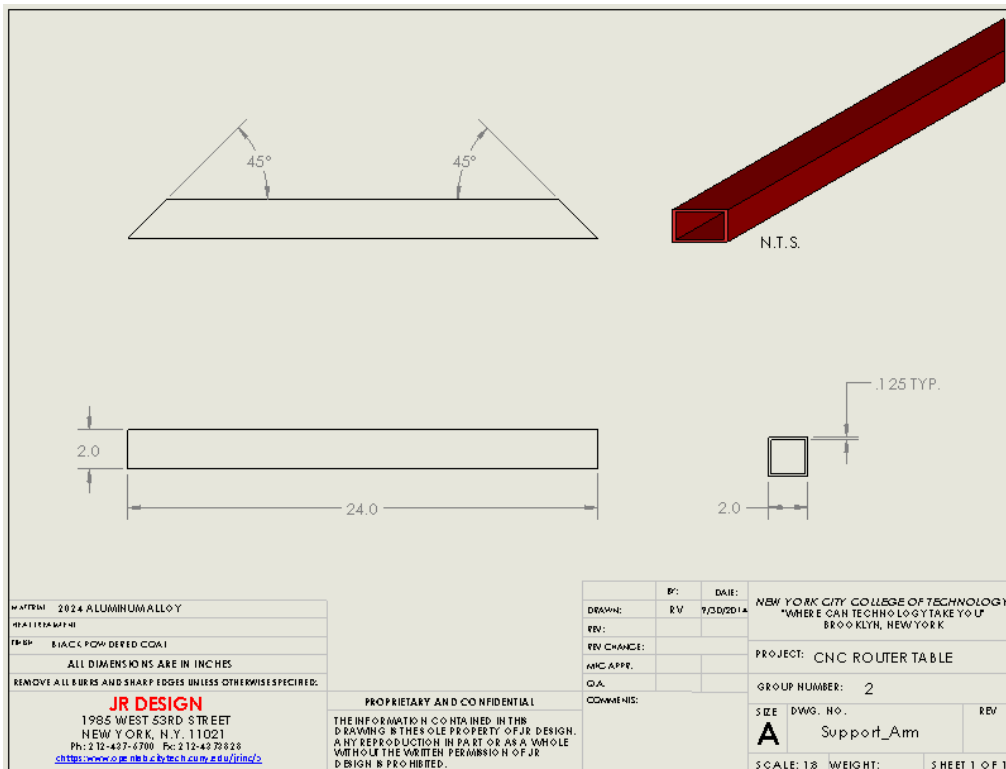



3.2 Continuation
Detailed Product Drawing

Part Drawing 9

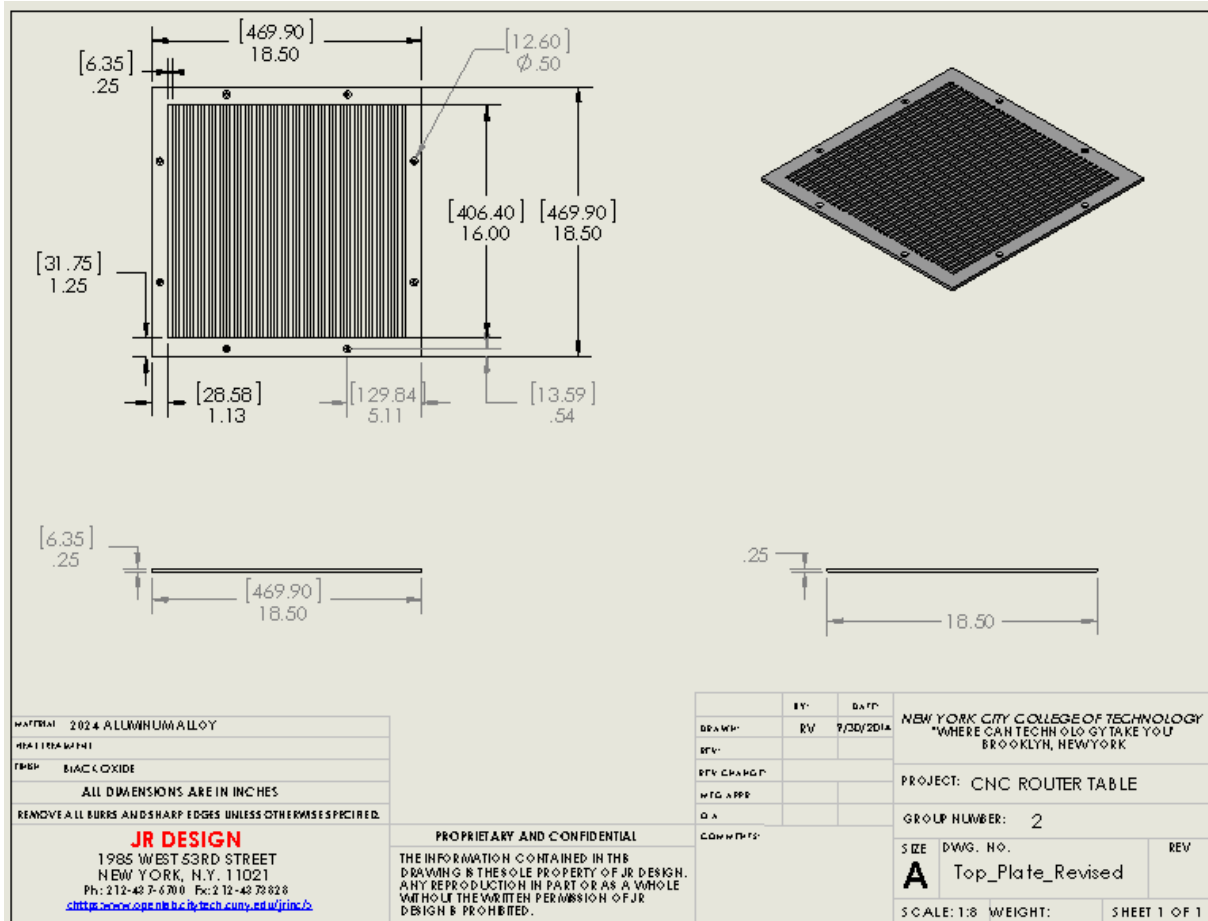



3.3 Motion Analysis

A motion analysis was conducted after completing the detailed CAD designs and the assembly. By doing so, the team had the ability to encounter any possible collision. The images below help you visualize the possible movements that will be generated in final physical product.

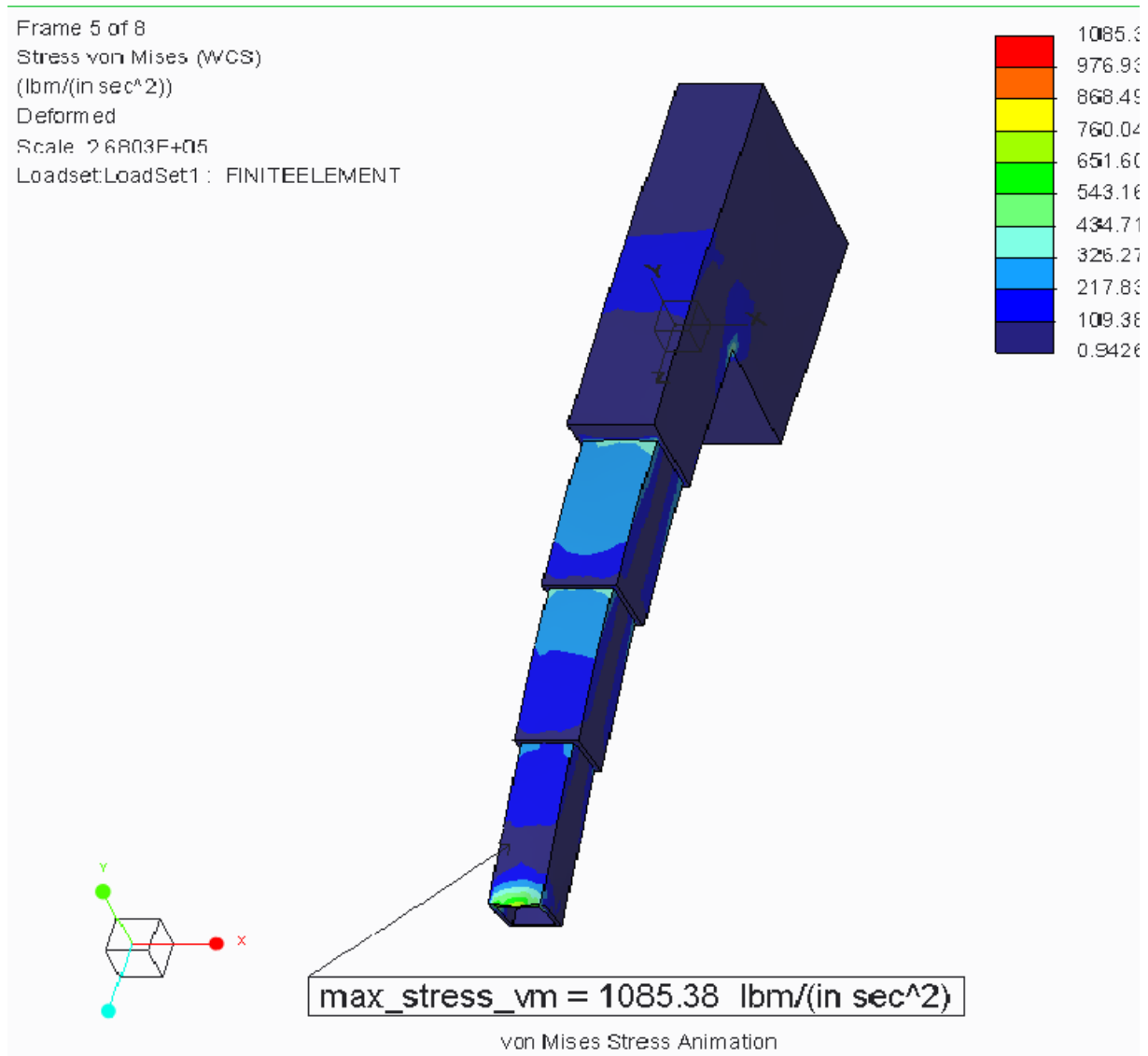



3.3 Continuation Motion Analysis

Displacement Mag (WCS)
(in)
Max Disp 8.3687E-06
Loadset:LoadSet1 : FINITEELEMENT

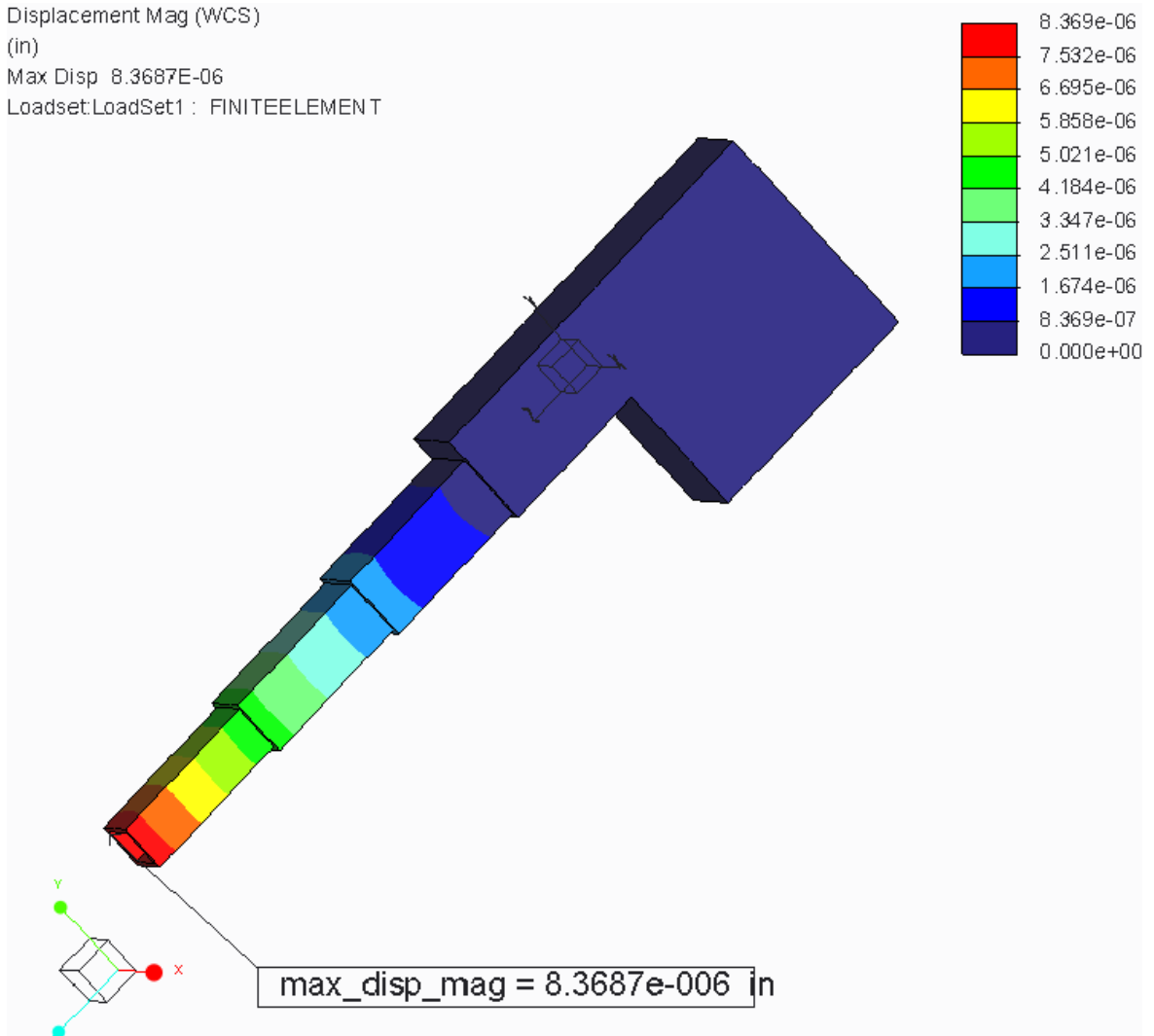



3.4 Assembly View

The following image shows the CAD (*Computer Aided Design*) final assembly.

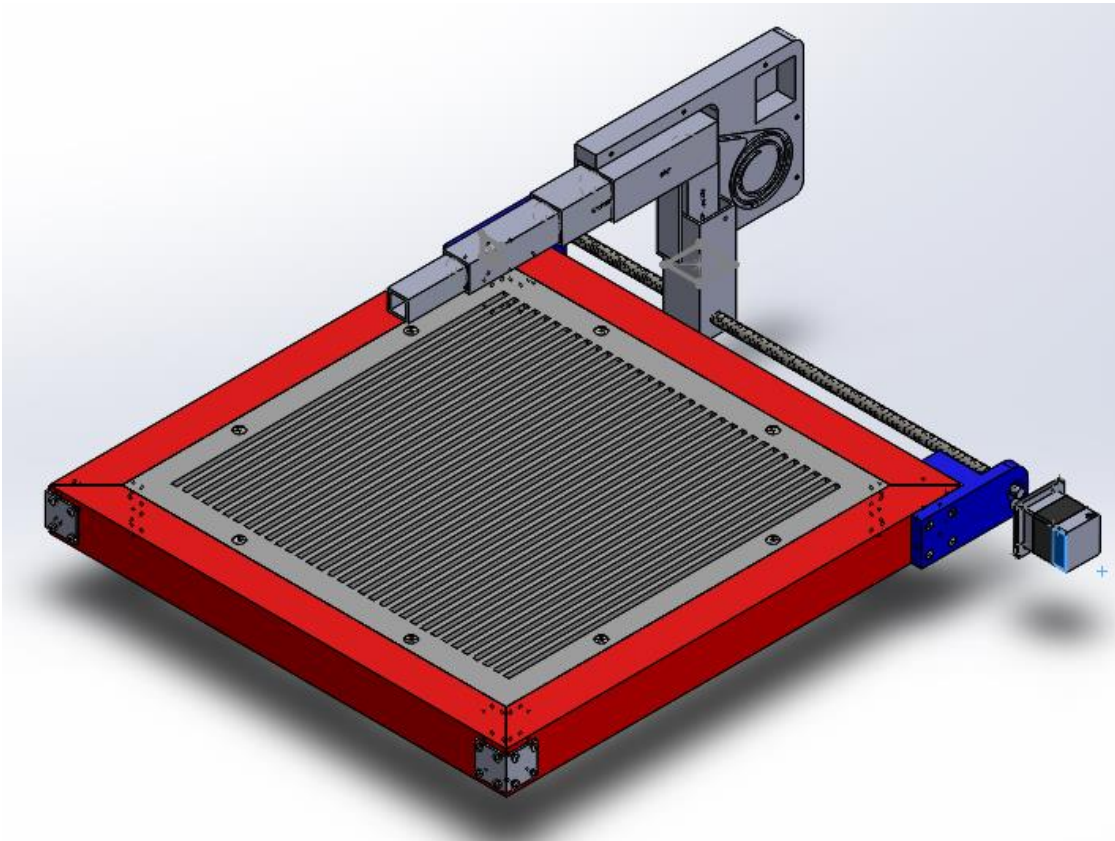

a) Engineering Drawing of the Exploded Assembly View

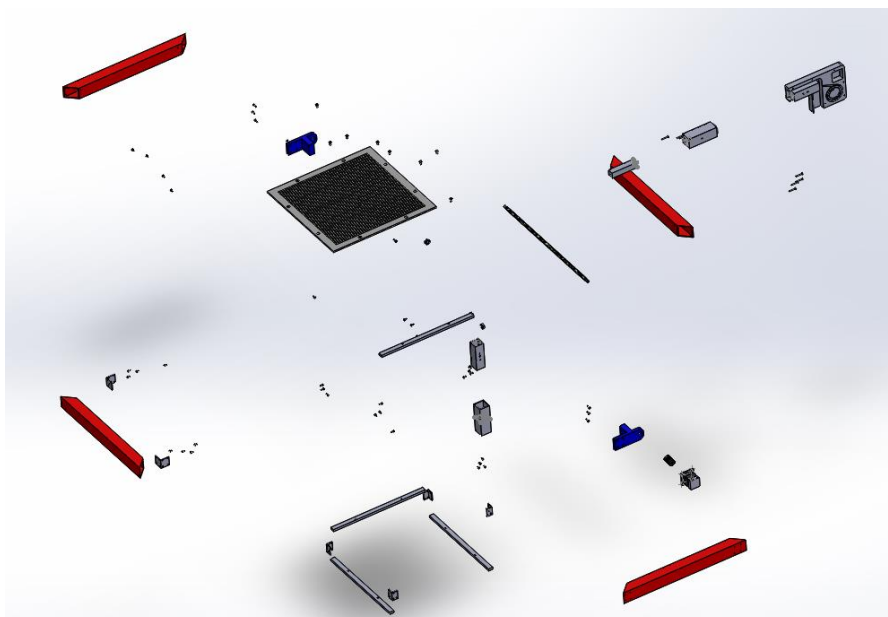



b) Bill of Material

The following image shows a list of material/components that are needed in order to assemble the (JR)² Router Table and put it to function. All of the components will be supplied in a package in combination to an easy-to-follow assembly instruction.

ITEM NO.	PART NUMBER	QTY.
1	Vertical Base	1
2	Vertical Extension	2
3	Bottom Base	1
4	Support Arm	4
5	Inner Arm Supports	4
6	LS Bearing SupportBlk	2
7	TOP PLATE	1
8	Lead Screw	1
9	Rack Rail	1
10	Outer Arm Supports	2
11	Stepper Motor Horizontal	1
12	10mm Coupling	1
13	Top Plate Support	4
14	B18.6.7M - M6 x 1.0 x 13 Type I Cross Recessed FHMS --13N	8
15	2nd extension	1
16	3rd Extension	1
17	B18.6.7M - M4 x 0.7 x 16 Type I Cross Recessed FHMS --16C	8
18	B18.6.7M - M4 x 0.7 x 8 Type I Cross Recessed PHMS --8C	16
19	B18.6.7M - M4 x 0.7 x 10 Type I Cross Recessed PHMS --10C	16
20	B18.6.7M - M4 x 0.7 x 30 Type I Cross Recessed FHMS --30C	8
21	Bearing	3



10/28/2014

JR CNC Router Table – (JR)², INC – Group #2

Innovative Computer Numeric
Control Machine operated by a
mechanical arm

Chapter 4

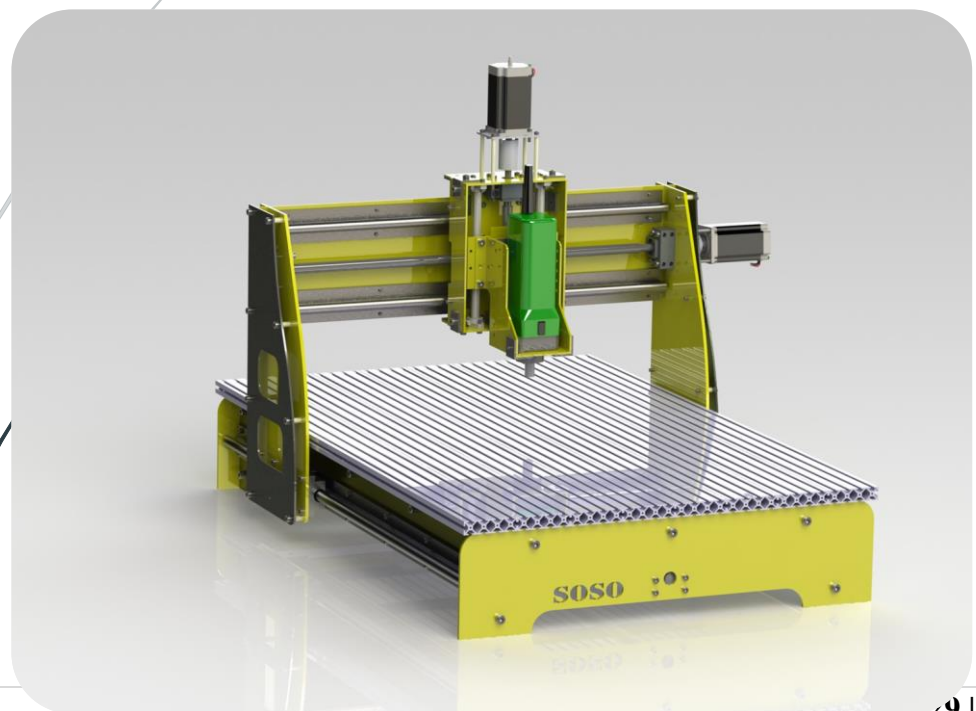



Chapter 4: Manufacturing Plan

4.1 Manufacturing Processes of Designed Parts

It is to be understood that the manufacturing process should be well planned before it starts. The disposition of time as well as the availability of materials, components and tools/equipment needs to be considered. Fortunately, by creating research beforehand and a detailed product design; helps (JR)² Inc. tremendously. This is because the team knows the availability of the material and components that were considered since it was decided during the design process. Least but not last, it is important to mention that the team plans to manufacture certain parts due to the fact that they are special (non-standard) pieces.

It is possible that the team may encounter problems when the manufacturing process of the parts starts. This is a very realistic and common situation which occurs in the manufacturing world. On the other hand, it can be avoided at the design stage. In the case of (JR)² Inc., the team spent a long period of time thinking about possible errors that can be encountered and for those, solutions were brought up. For example, if the selection of a specific material can cause negative effects, the team should consider alternative options at the design stage. This will help avoid futuristic problems.

The following image shows a General Process/Sequence that (JR)² Inc., has followed throughout the project

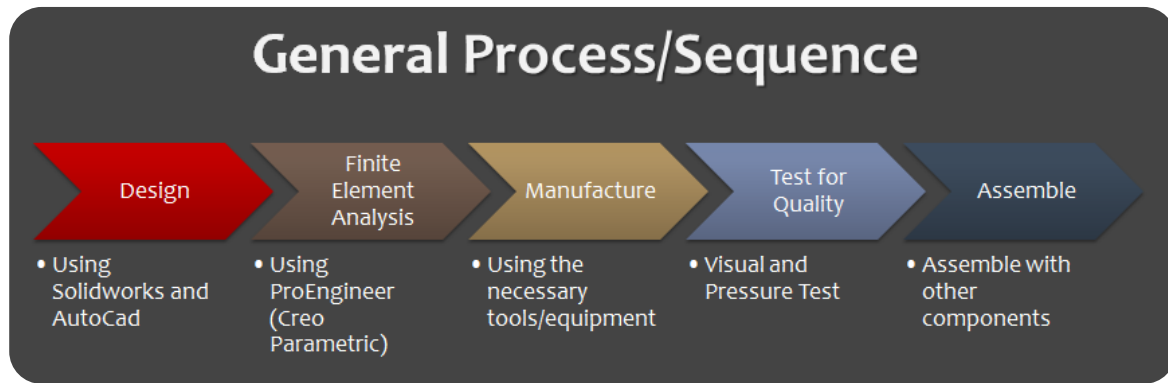

The tools that will be used the most are the following:

(JR)² CNC Router Table	Tools to be used
	3D Printer
	Water Jet Cutter
	Miter Saw
	Drill Press
	Table Saw
	Angle Grinder
	Drill
Measuring Tape	

and more



4.1 Continuation Manufacturing Processes of Designed Parts

The following image shows the process that certain parts will need to go through for completion. The steps should be followed in the sequence stated.

Figure 7

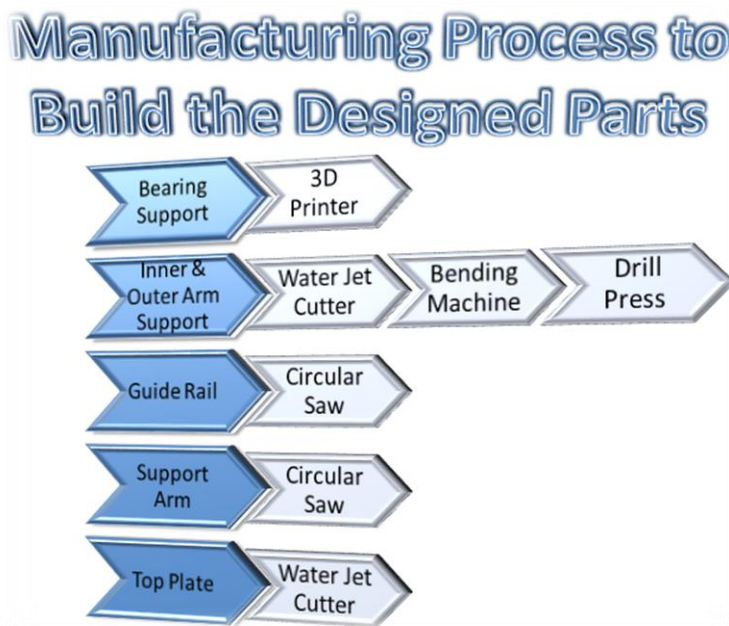

As Figure 7 shows:

- The manufacturing of the Bearing Support will first go through a test and depending on the result obtained, the material will then be chosen. First, a test will be run using the 3D Printer that is located in the New York City College of Technology (NYCCT). The 3D Printer will print the part (with the inside hollow) in ABS (*Acrylonitrile Butadiene Styrene*) which is a very durable material. If the piece fails, the team will then proceed to manufacture the Bearing Support using Aluminum 2024.
- The Inner and Outer Arm Support are two of the most time consuming parts to be manufactured. They both will be cut using a Water Jet Cutting Machine which is located in the New York City College of Technology (NYCCT). After this, the pieces will be collected and taken through a bending process. The pieces will be set to a bending degree of 90°. Finally, the Arm Supports will be taken to a Drill Press Machine and 8 holes of M4 x0.7 (*per piece*) will be created with the most precision as possible.
- The Guide Rail will be bought from an outside source/supplier. The team will have to cut the piece to the desired length which is 600mm (23.62")
- The Support Arm that will be used for the base/structure will need to be cut to exact length of 24" with 45° angle.
- The Top Plate (*Stainless steel*) outside area will be cut using a Water Jet Cutting Machine as well as the outside holes and the slots.



4.2 Schedule

It is to be acknowledged that every project needs a detailed schedule that needs to be done and followed very carefully in order to accomplish the main goal; which is to complete the project assuring to meet the deliverables and on time. Hence, the team created a detailed schedule which shows how the product will be built before the deadline set.