

# Engineering Graphics with AutoCAD® 2017

## **CHAPTER 2**

### *Fundamentals of 2D Construction*

# Figure 2-1

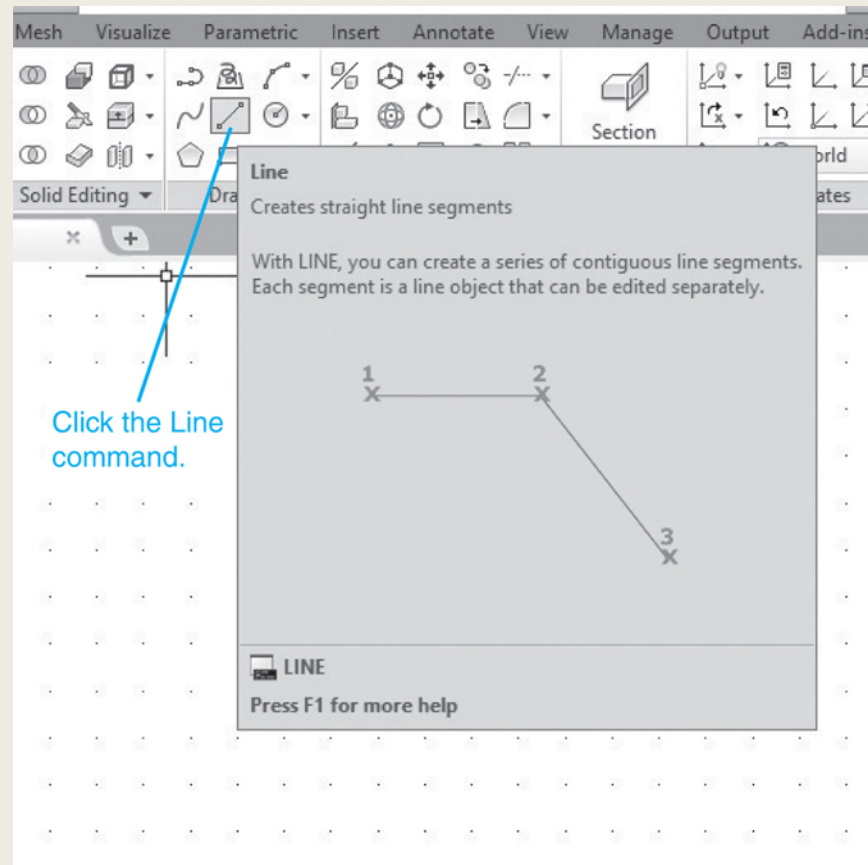

# Figure 2-2a

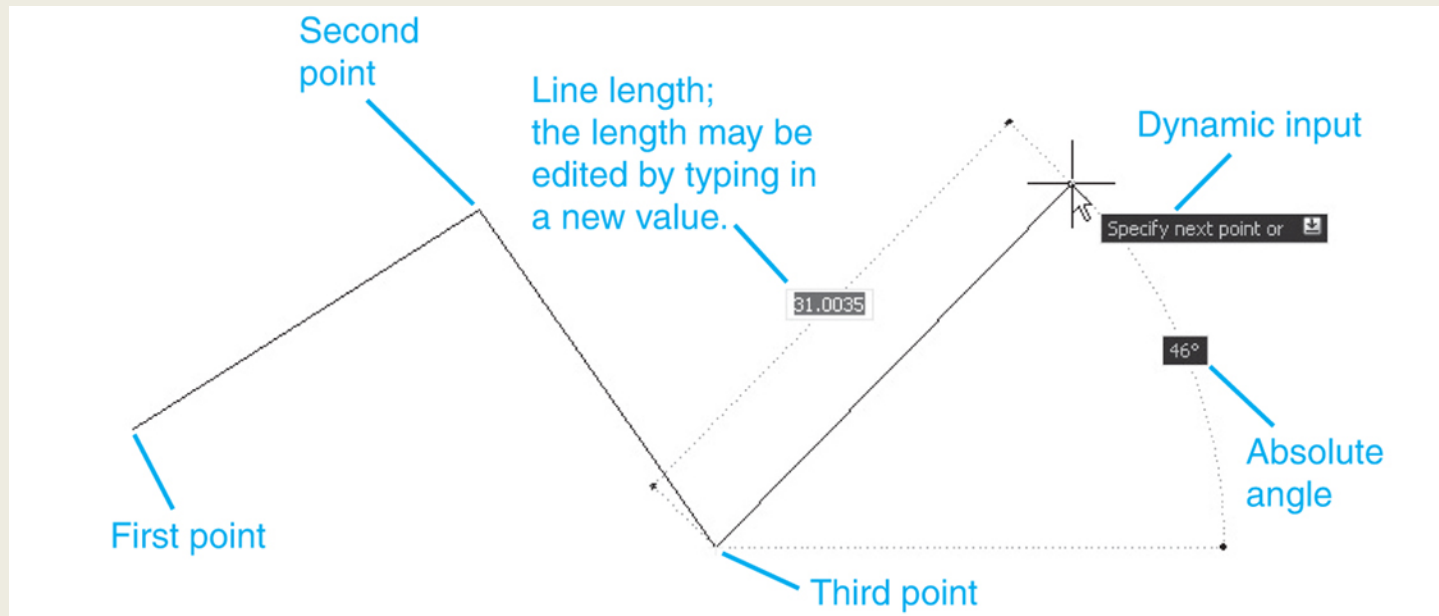

# Figure 2-2b

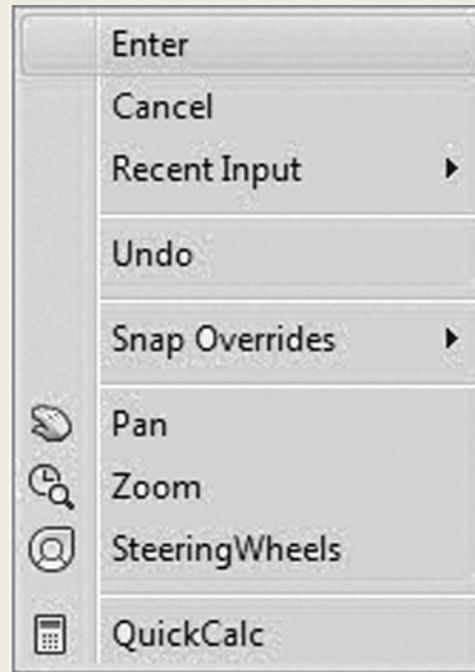

# Figure 2-3

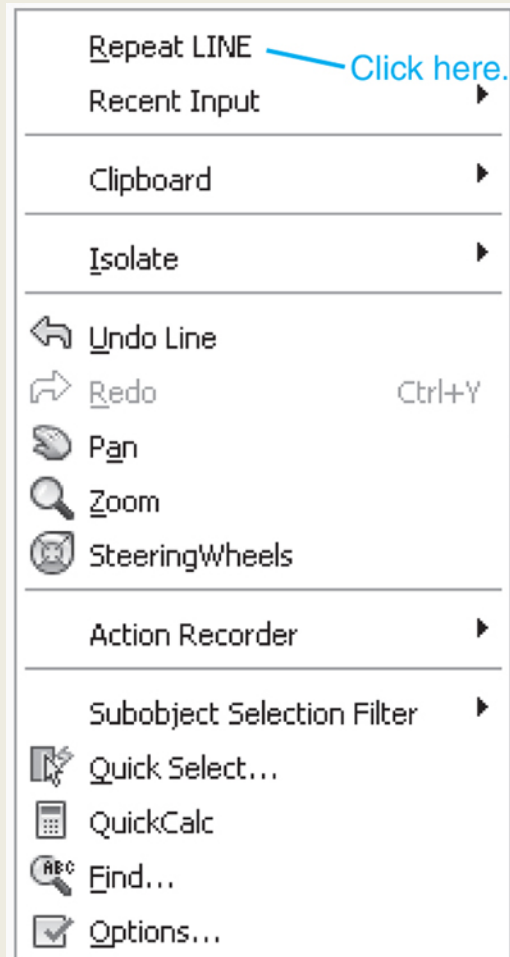

# Figure 2-4

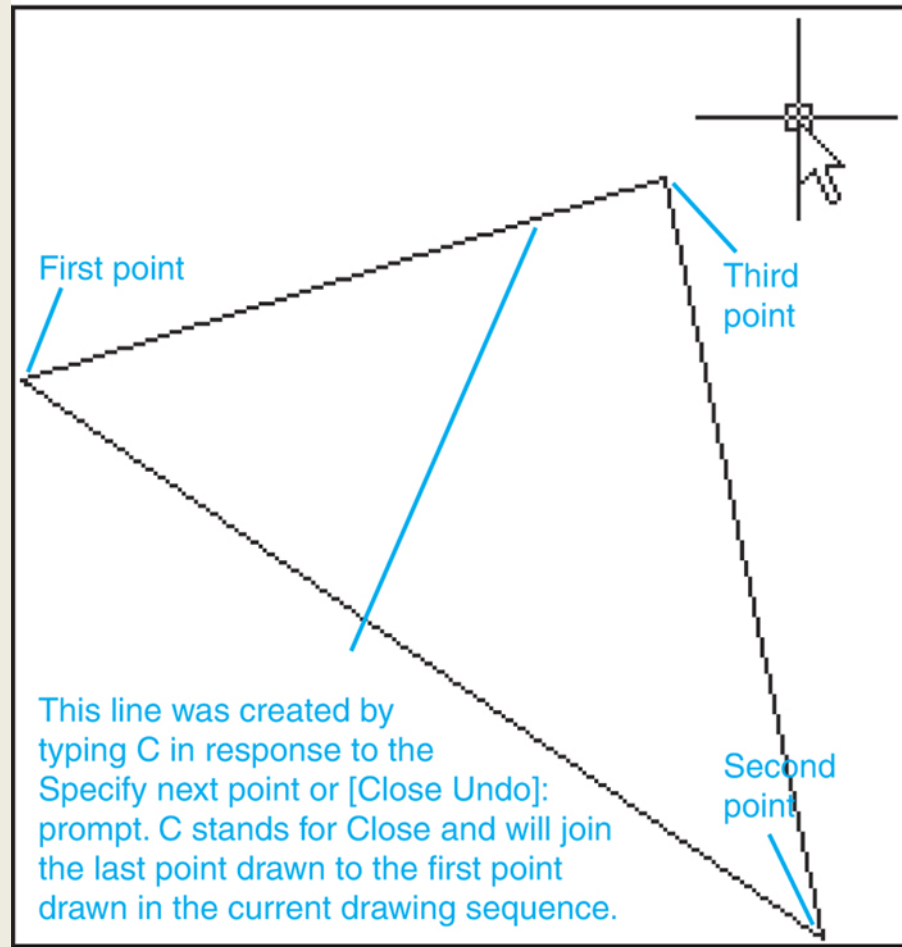

# Figure 2-5

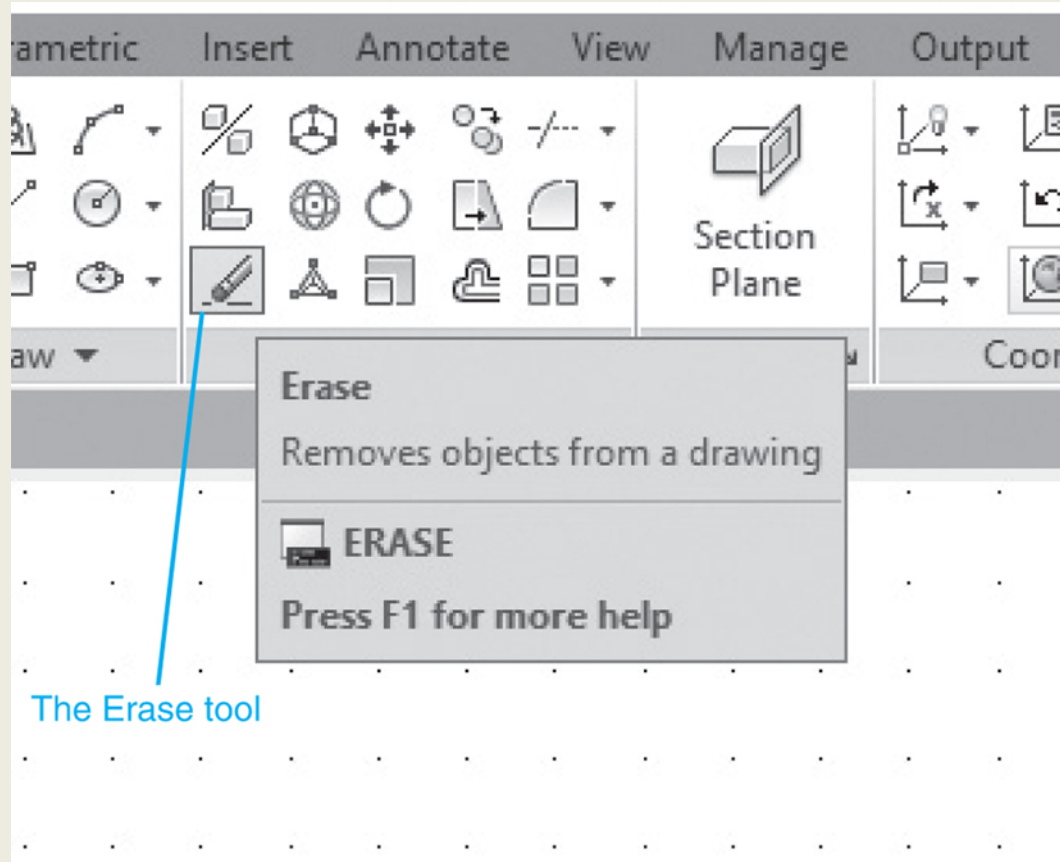

The Erase tool

# Figure 2-6

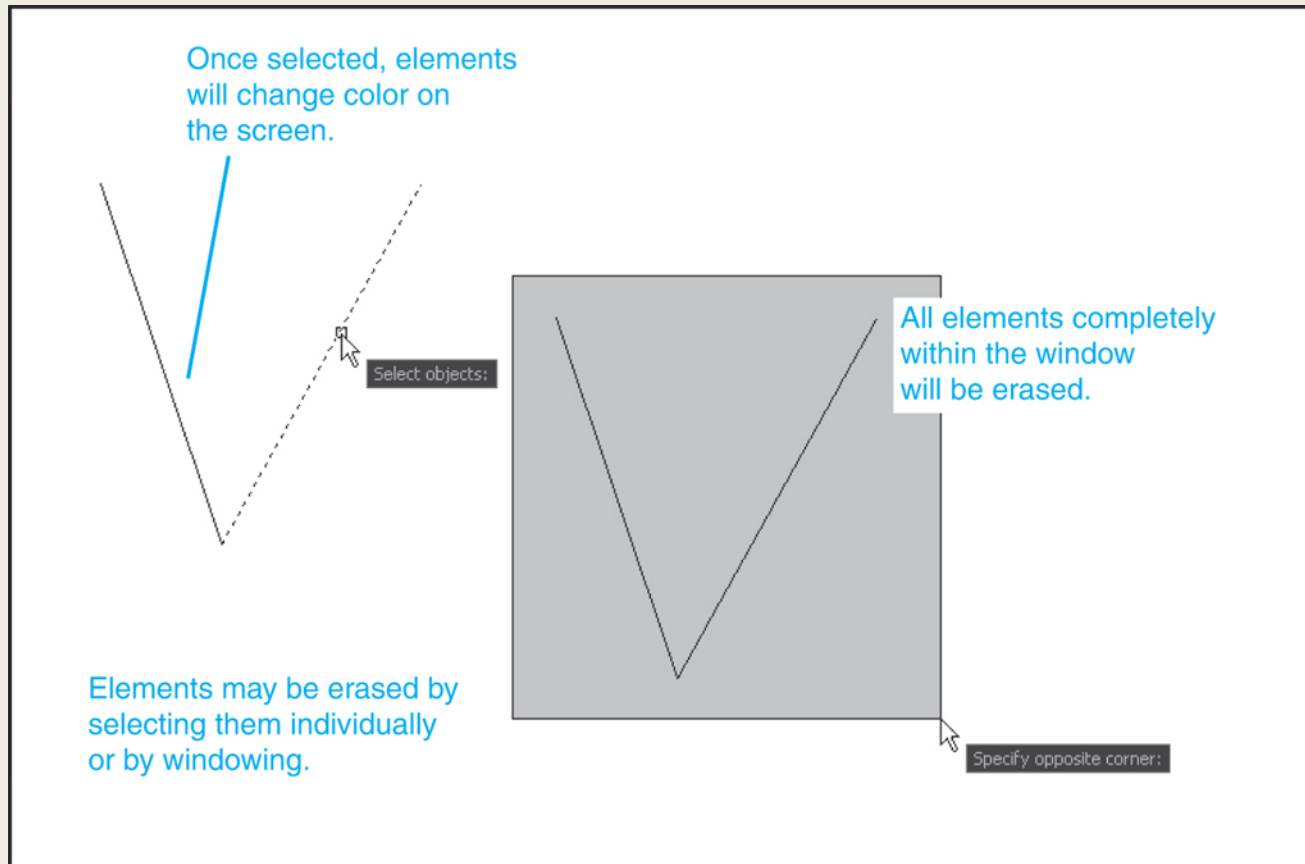



# Figure 2-7

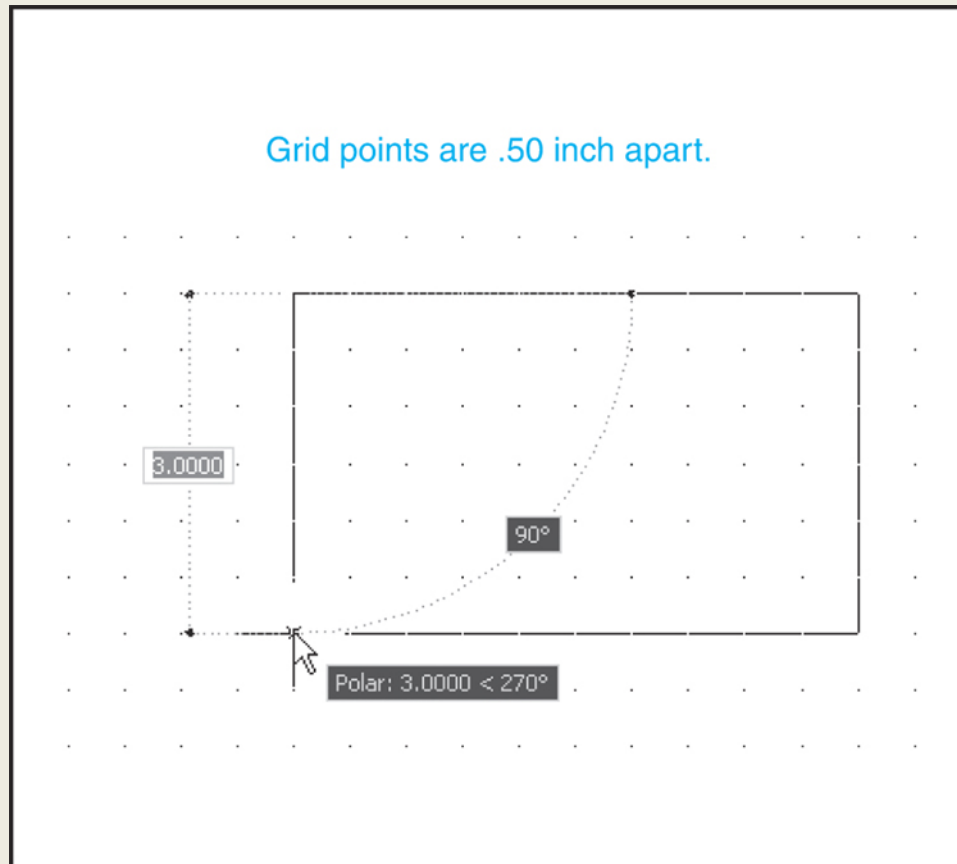

# Figure 2-8

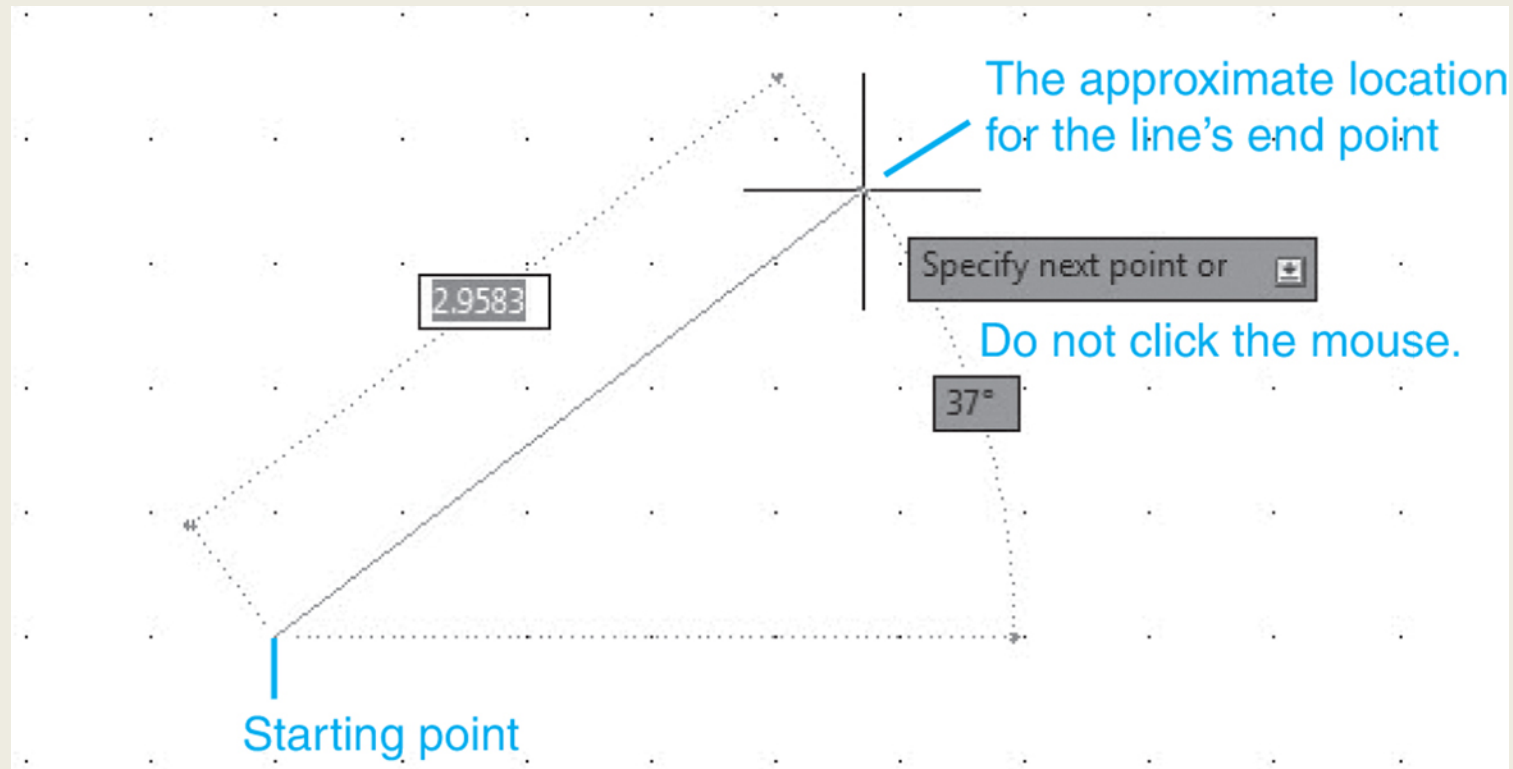

# Figure 2-9a

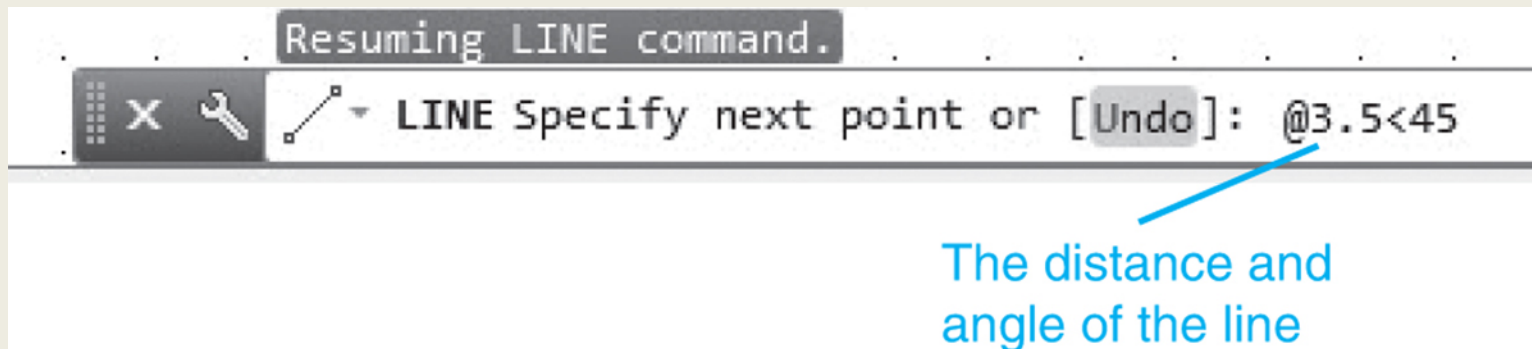

# Figure 2-9b

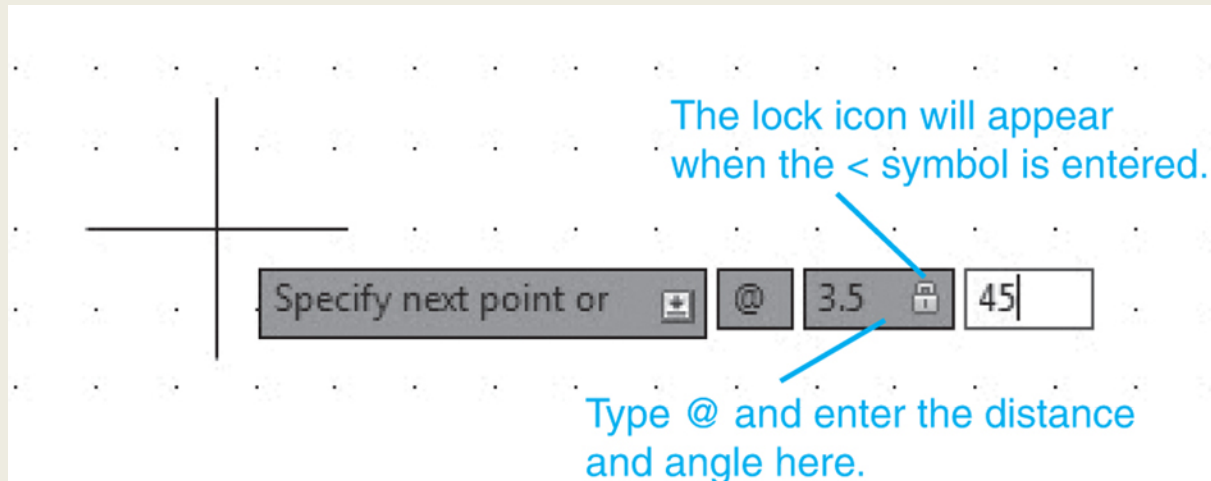

# Figure 2-10a

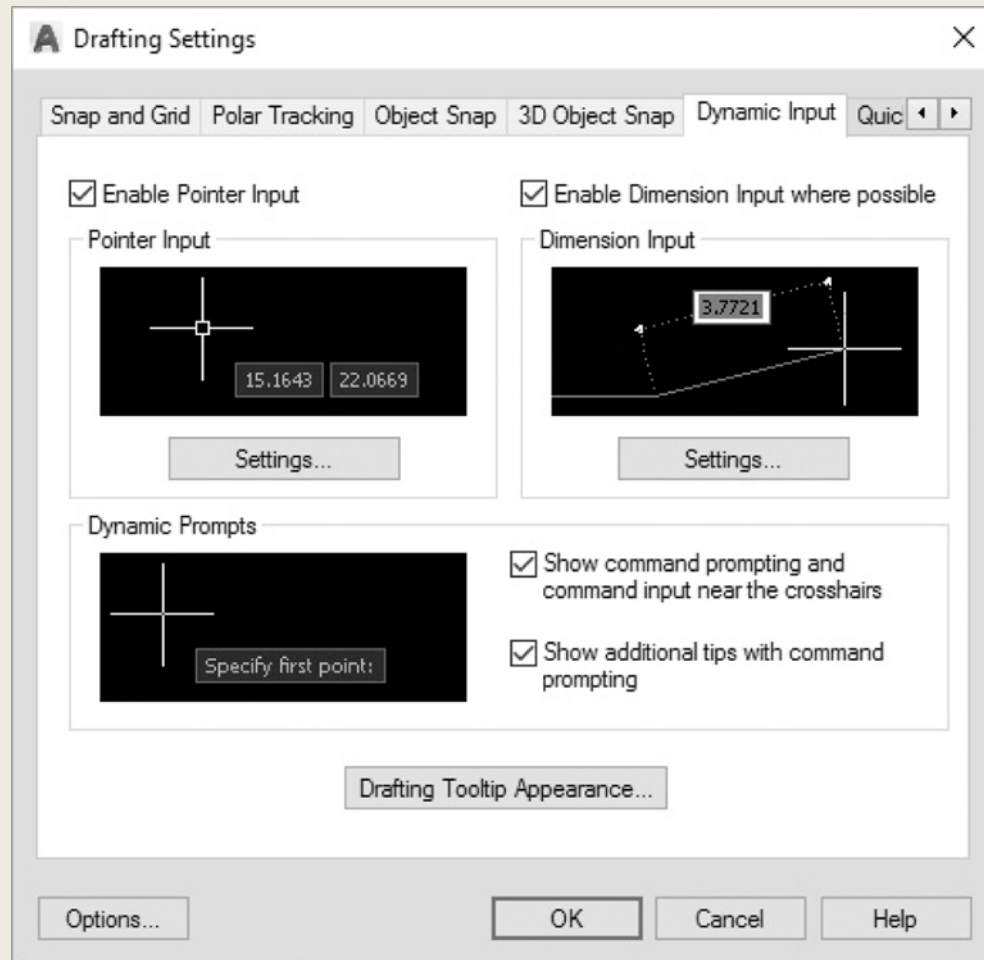

# Figure 2-10b

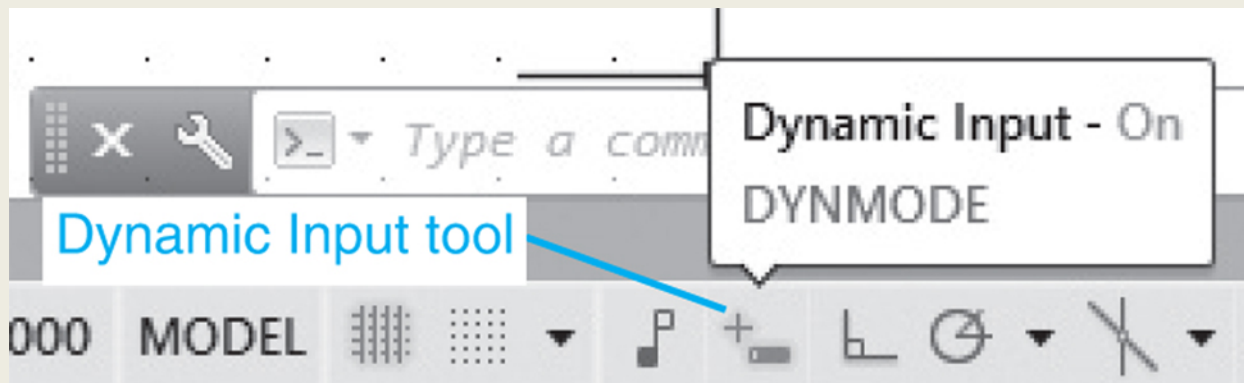

# Figure 2-11

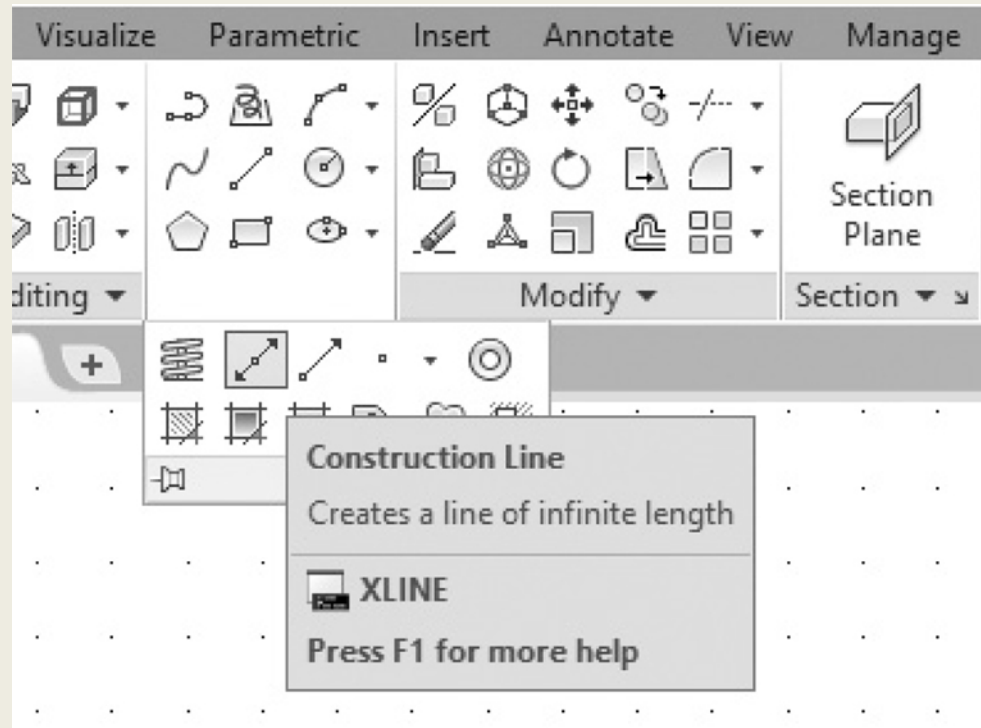

# Figure 2-12

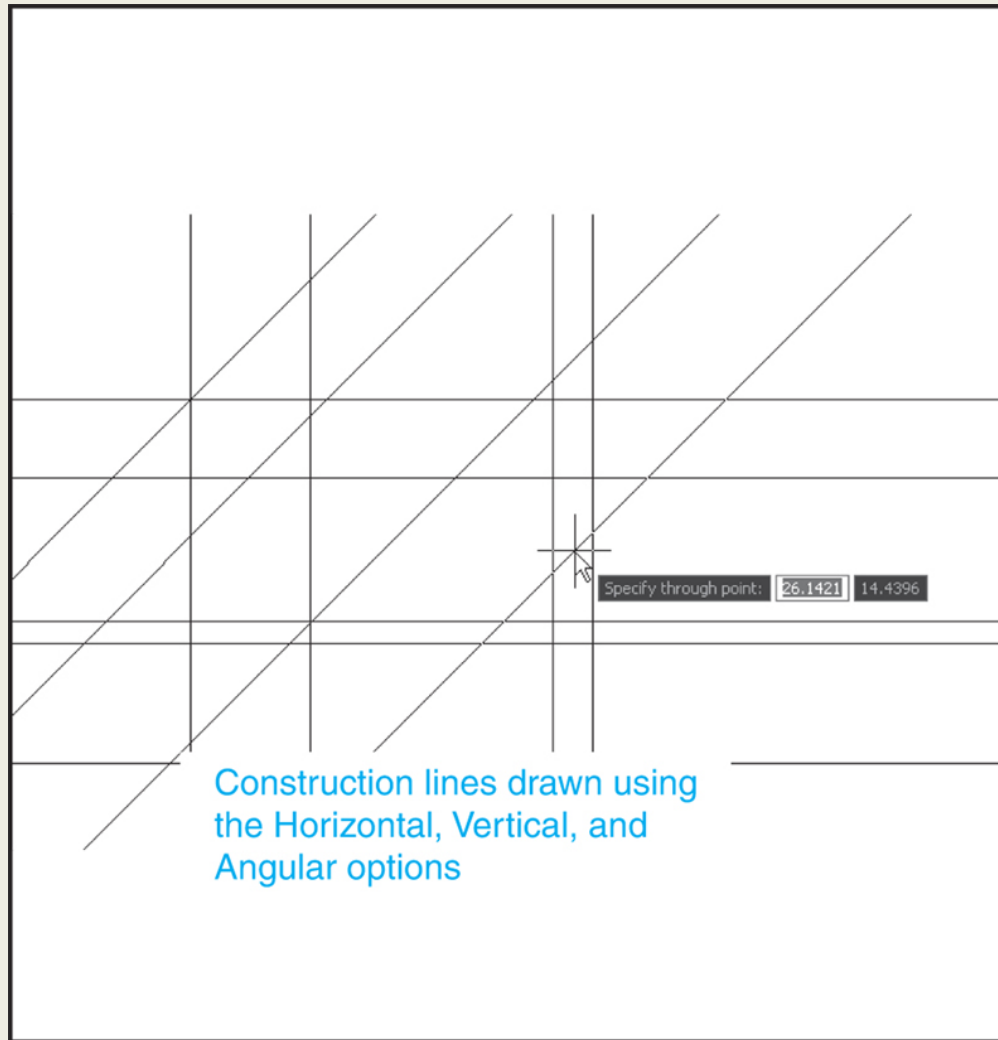



# Figure 2-13

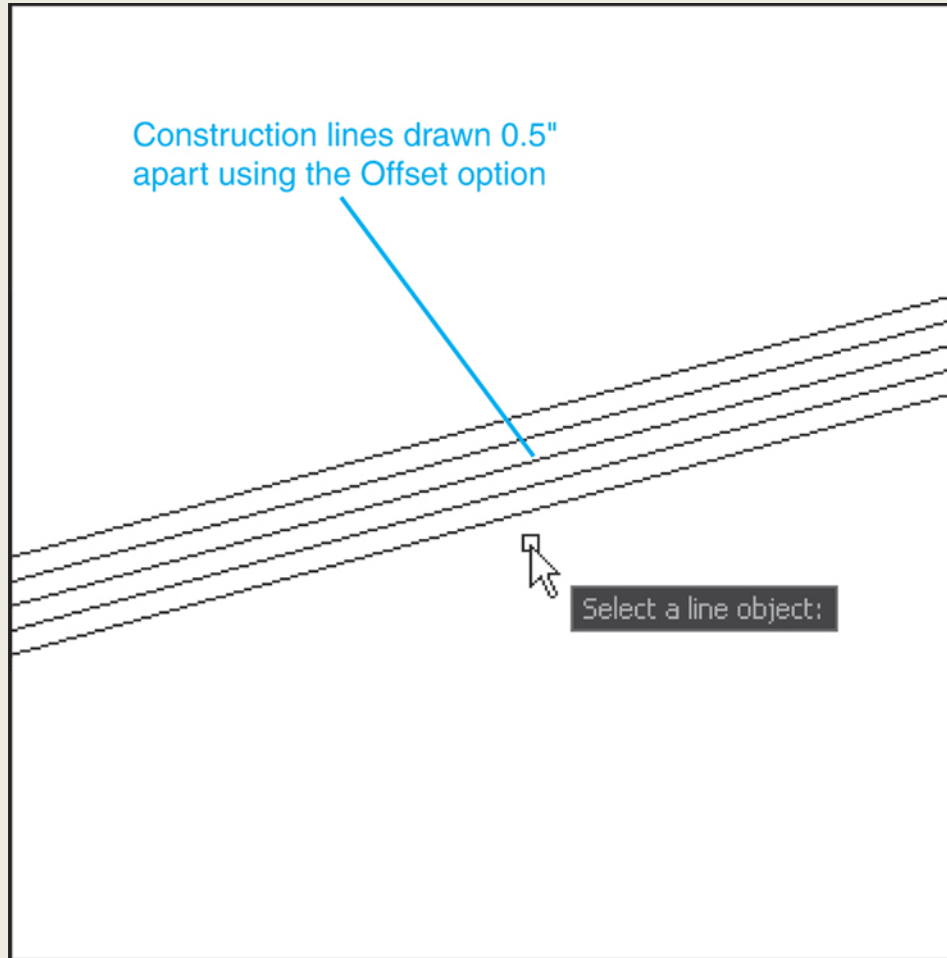

# Figure 2-14

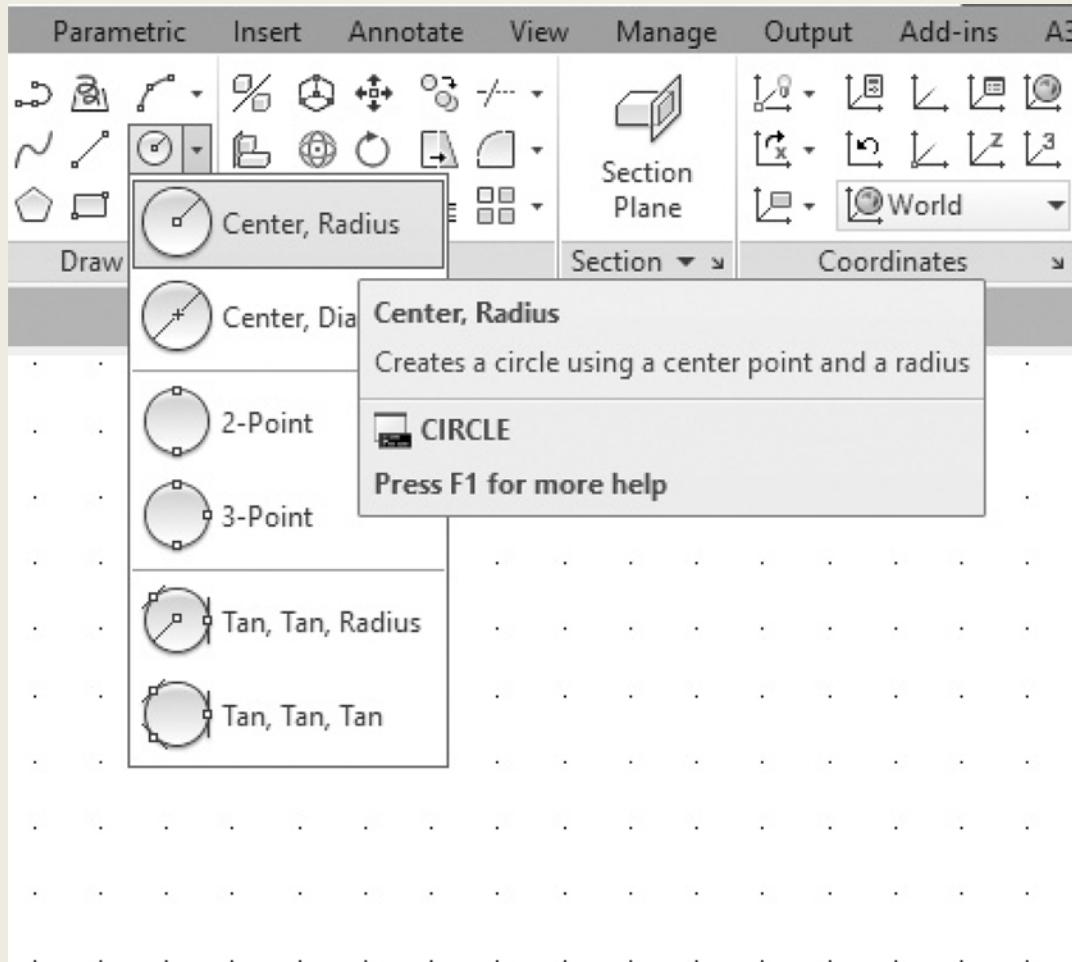

# Figure 2-14b

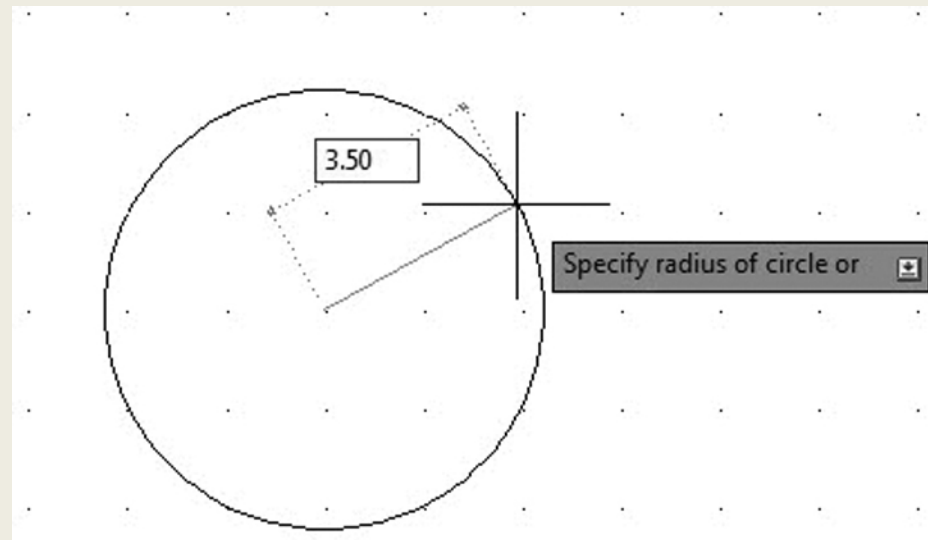

# Figure 2-14c

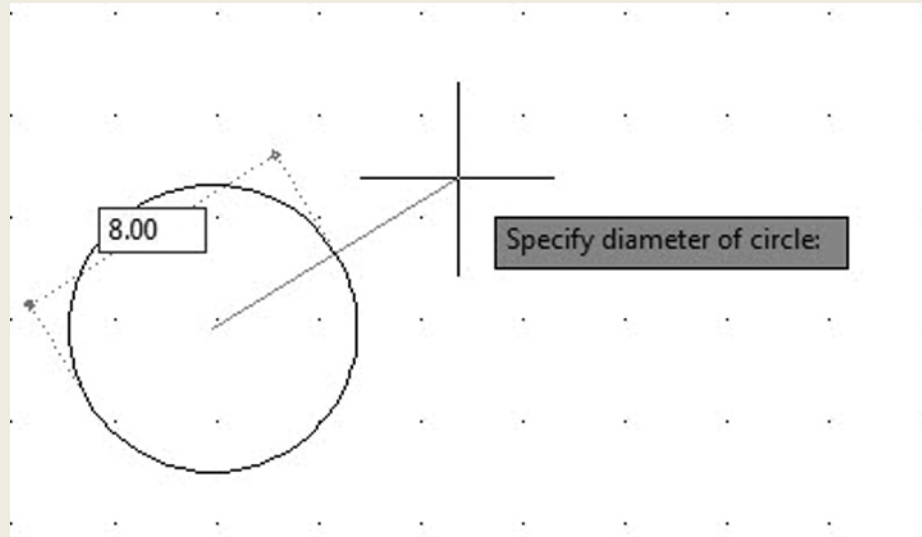

# Figure 2-15

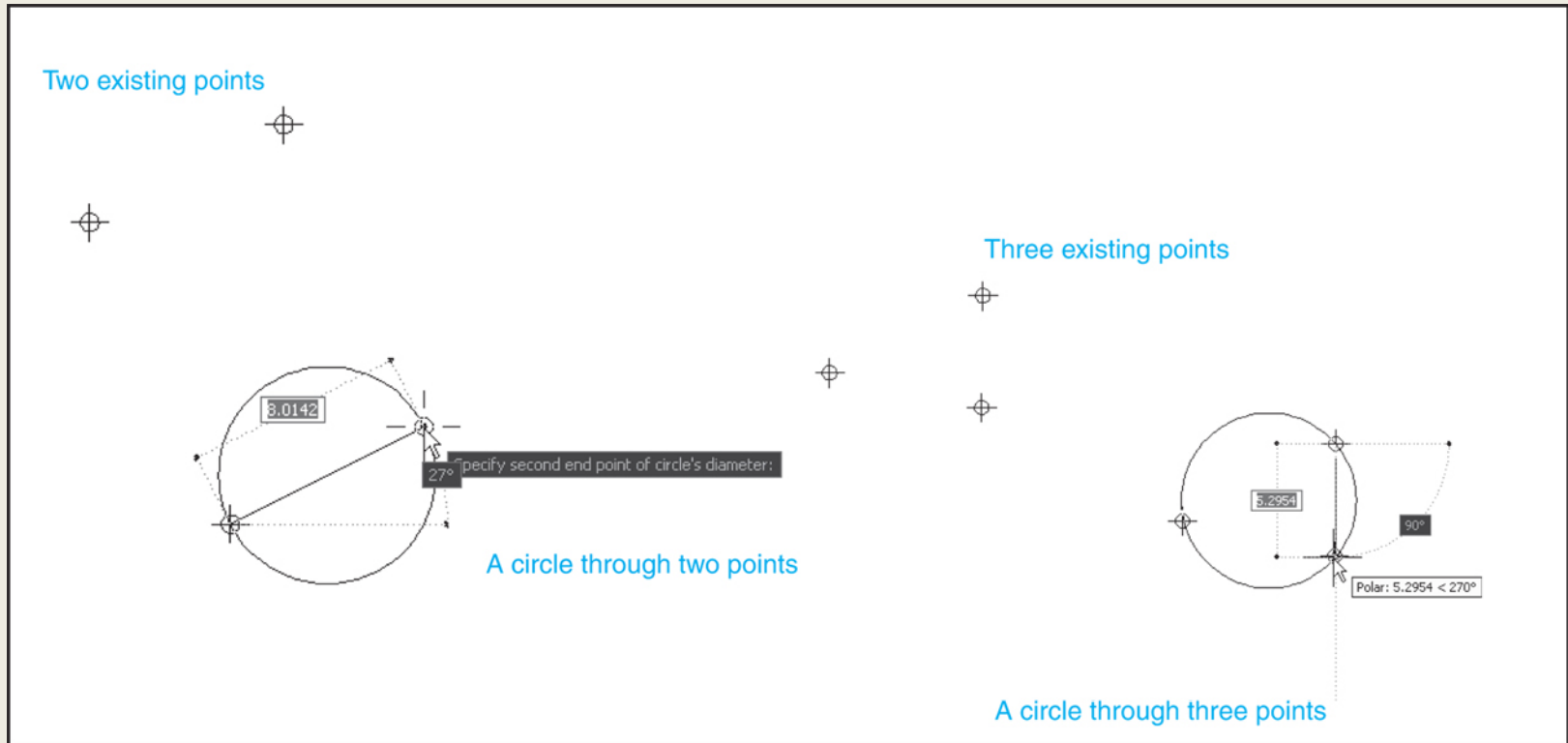

# Figure 2-16

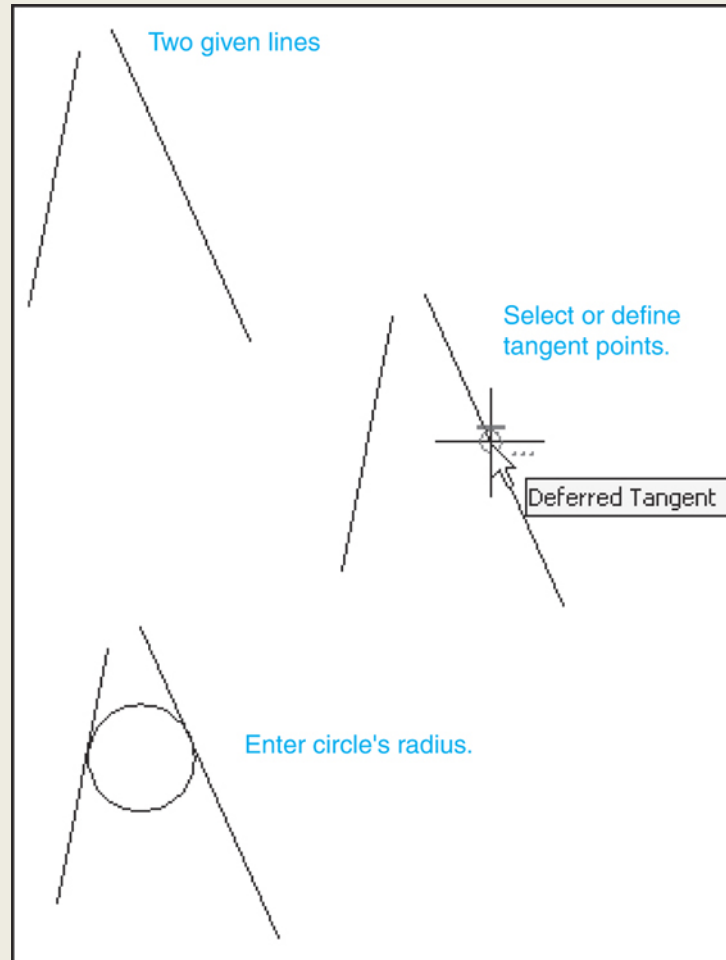

# Figure 2-17a

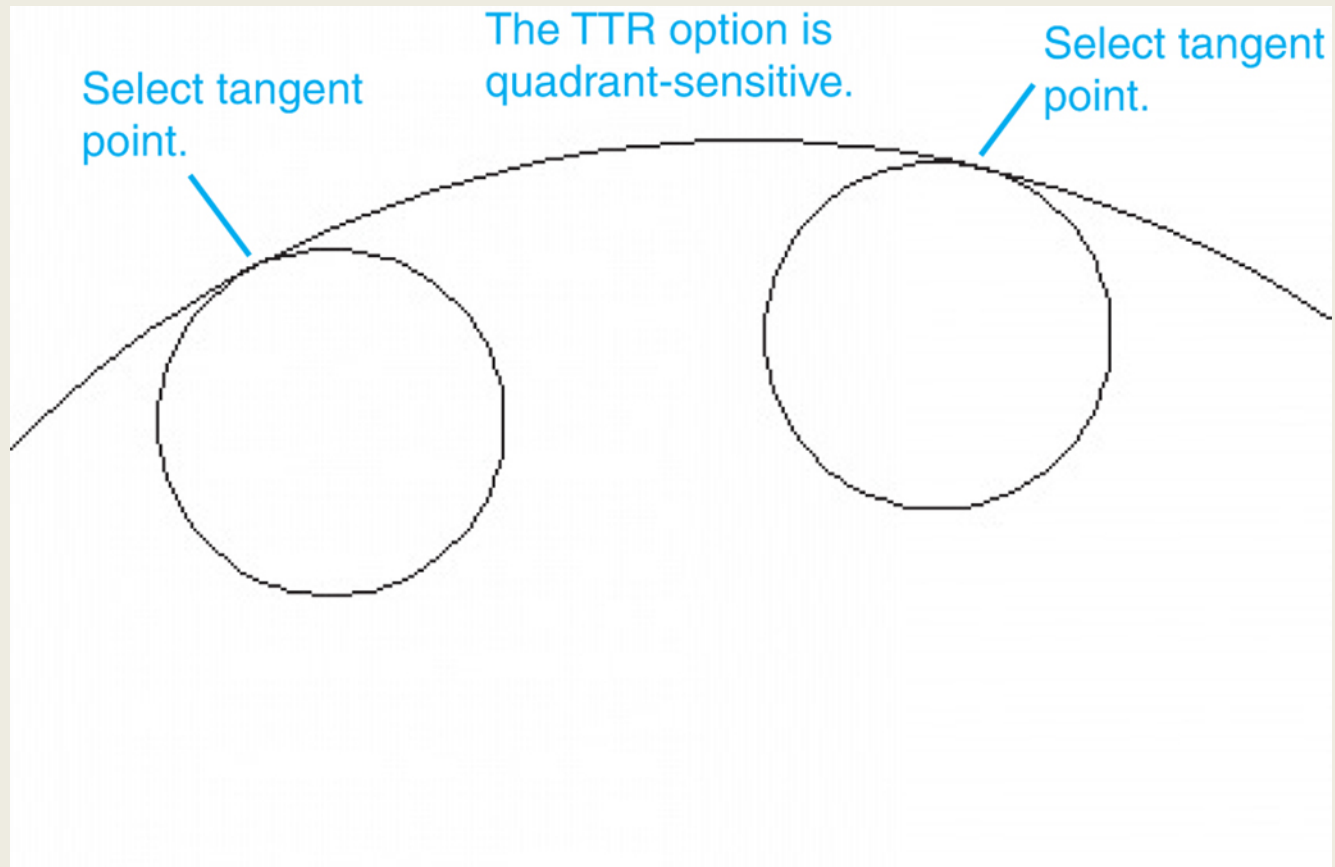

# Figure 2-17b

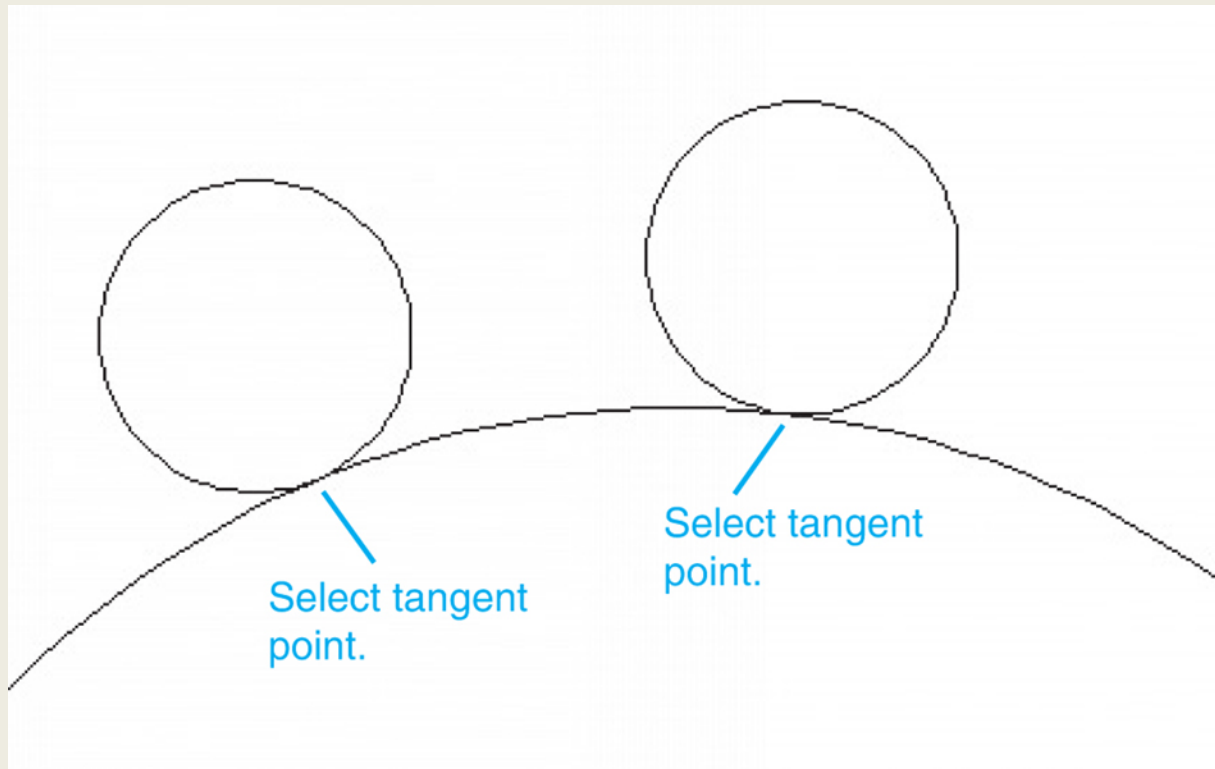



# Figure 2-18

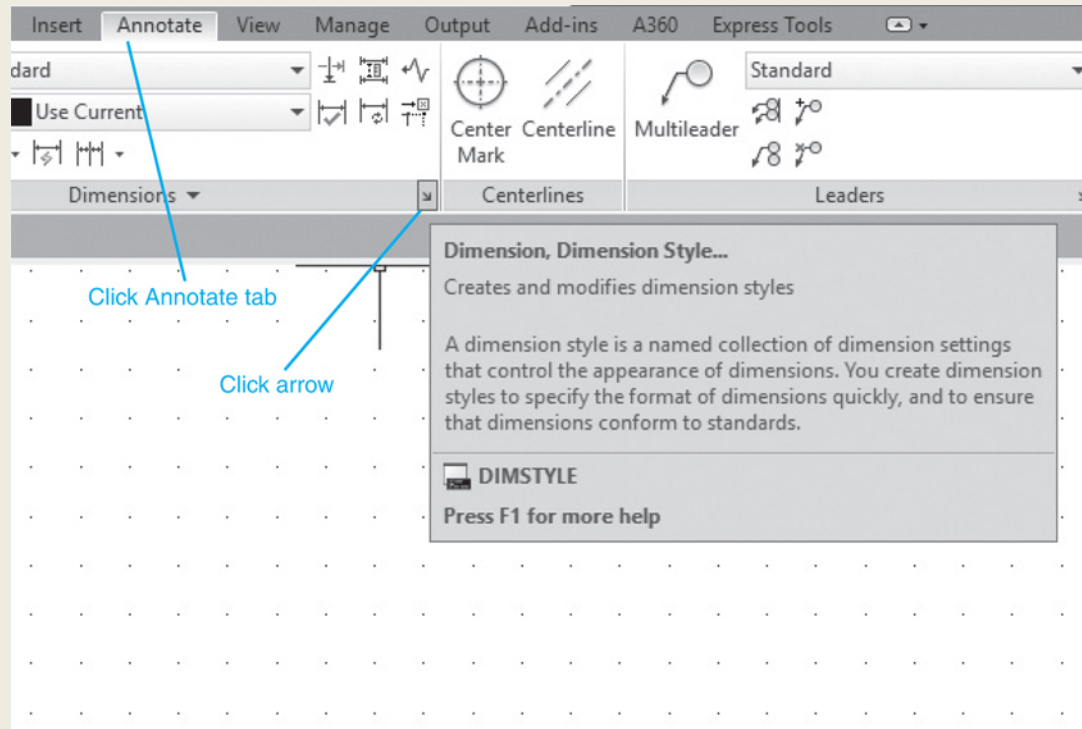

# Figure 2-19a

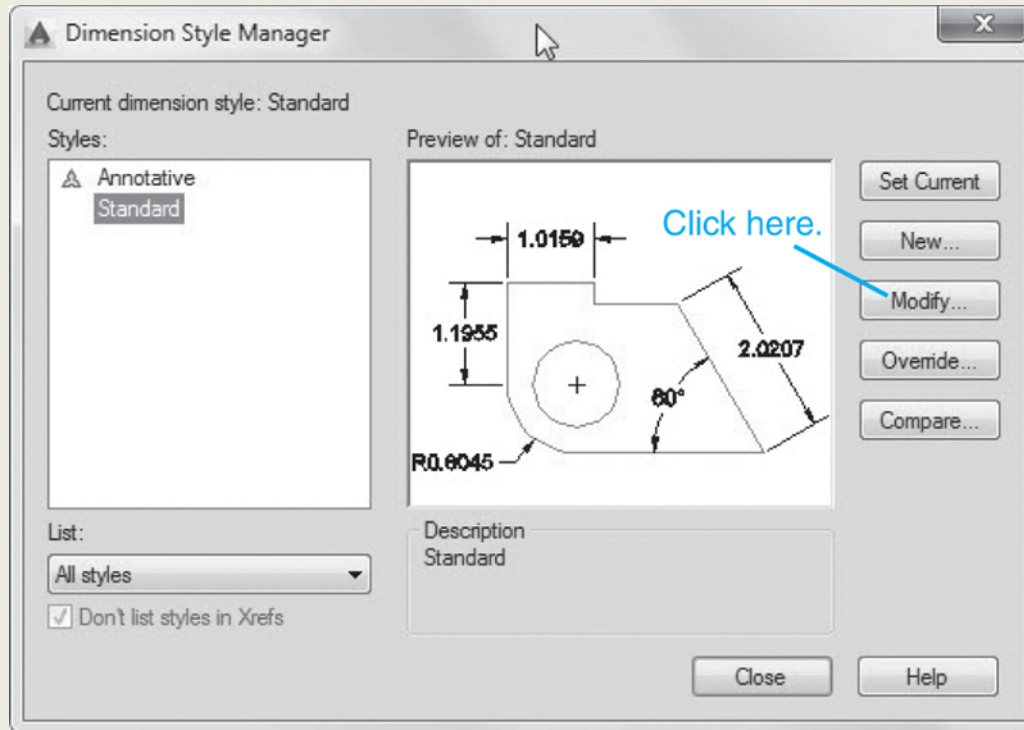

# Figure 2-19b

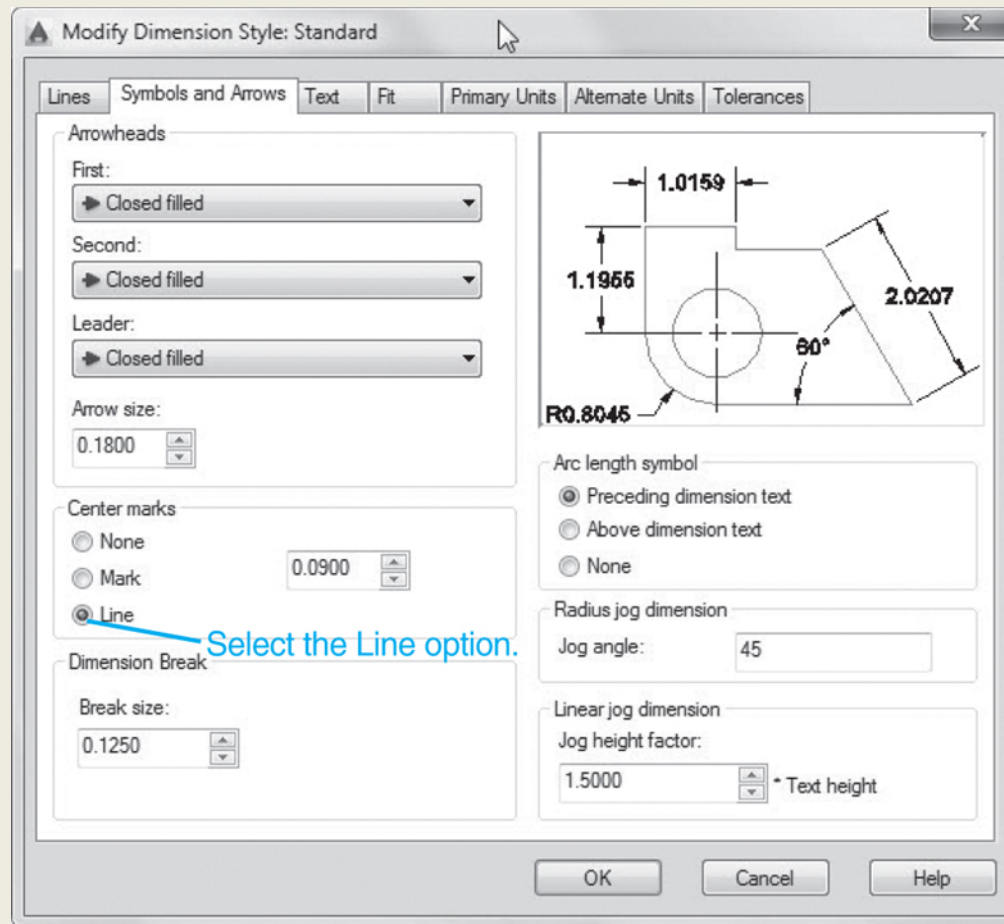

# Figure 2-20

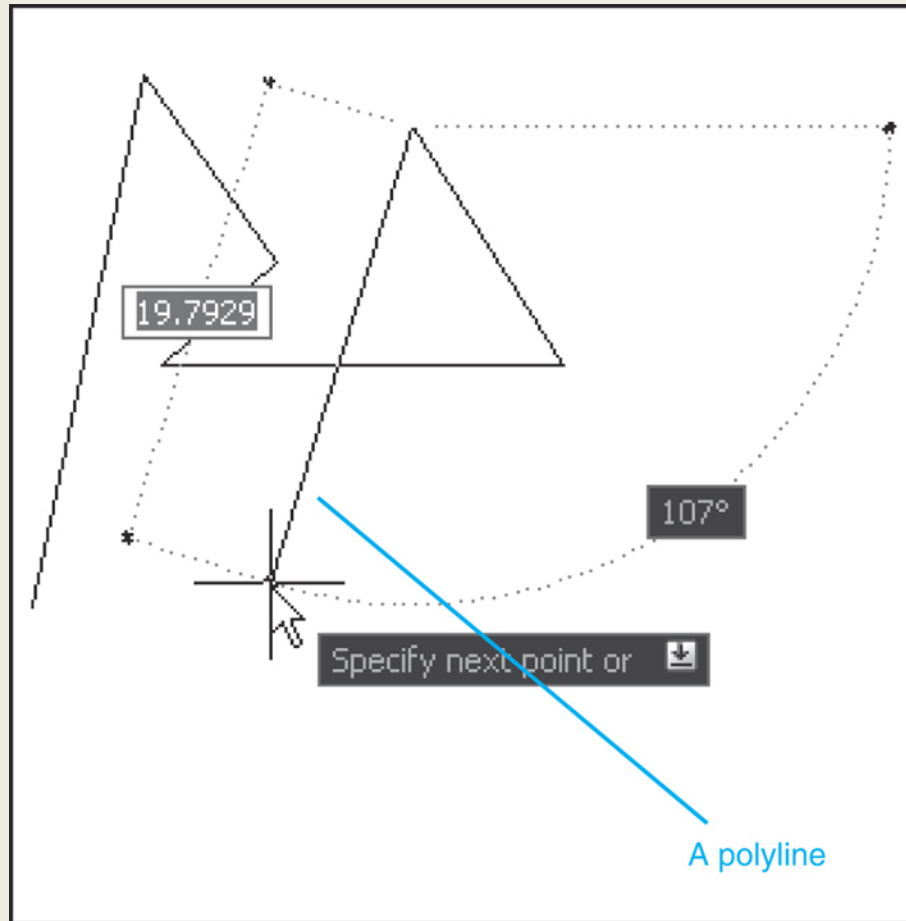

# Figure 2-21

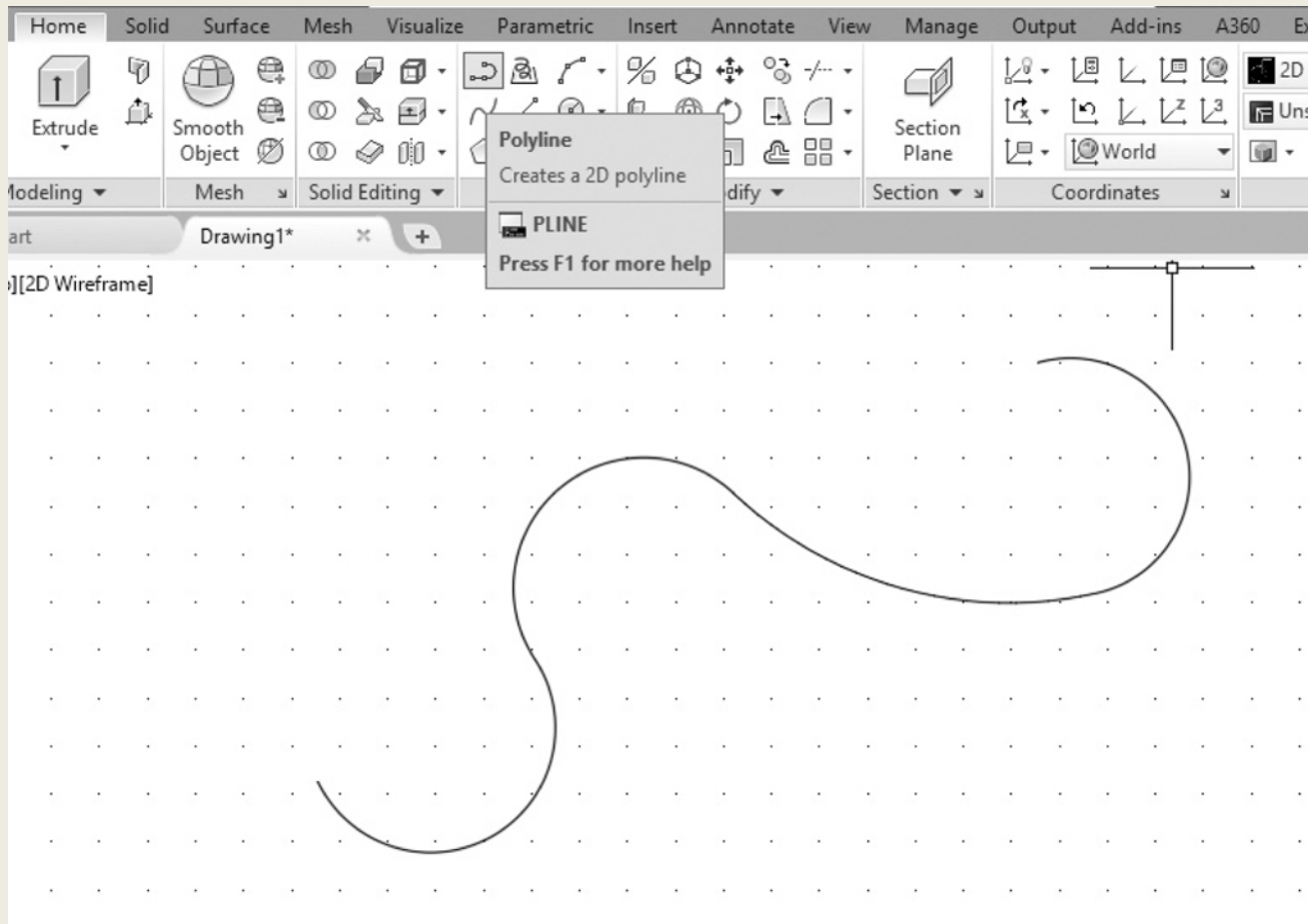

# Figure 2-22

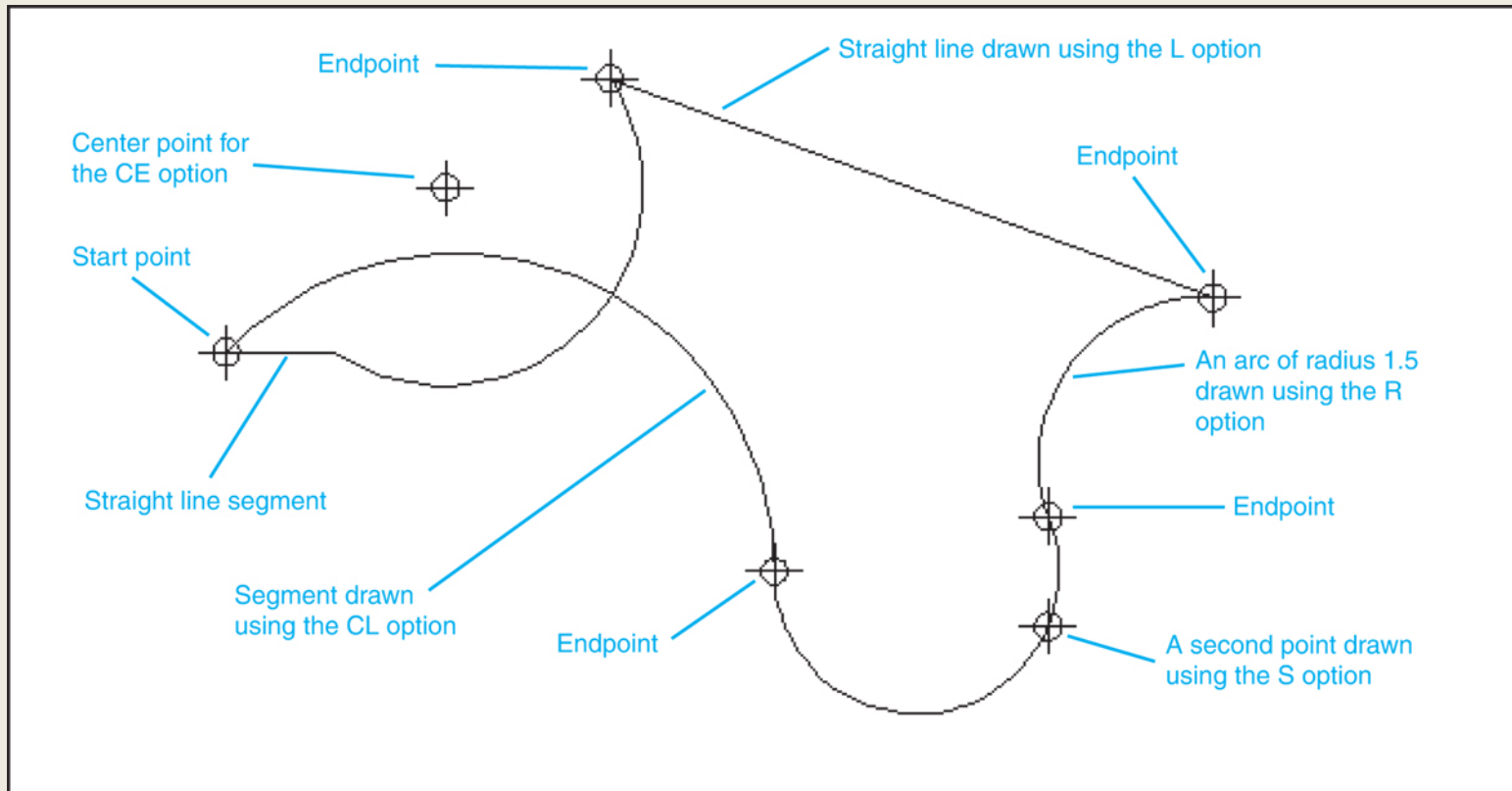

# Figure 2-23

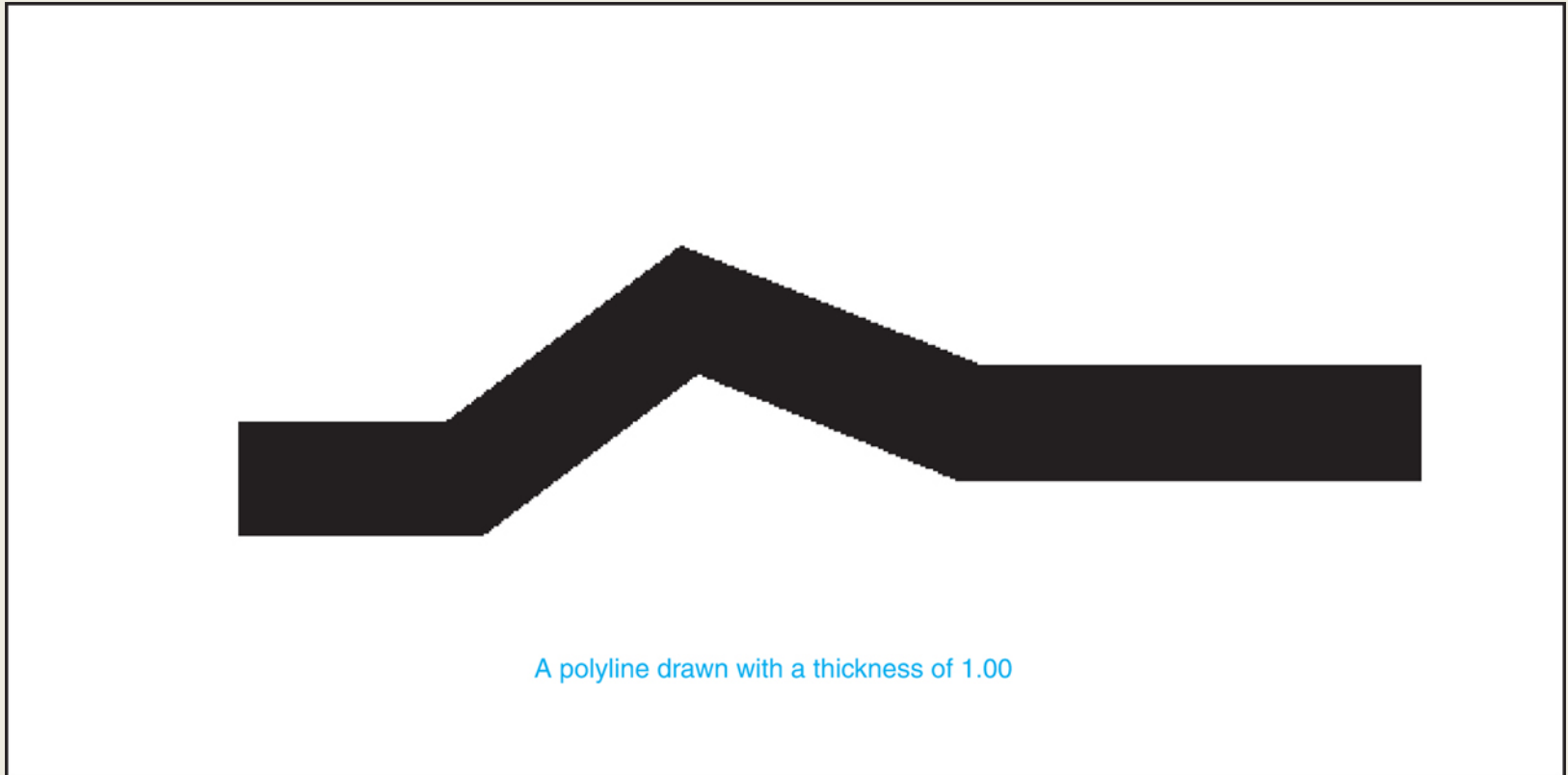

# Figure 2-24

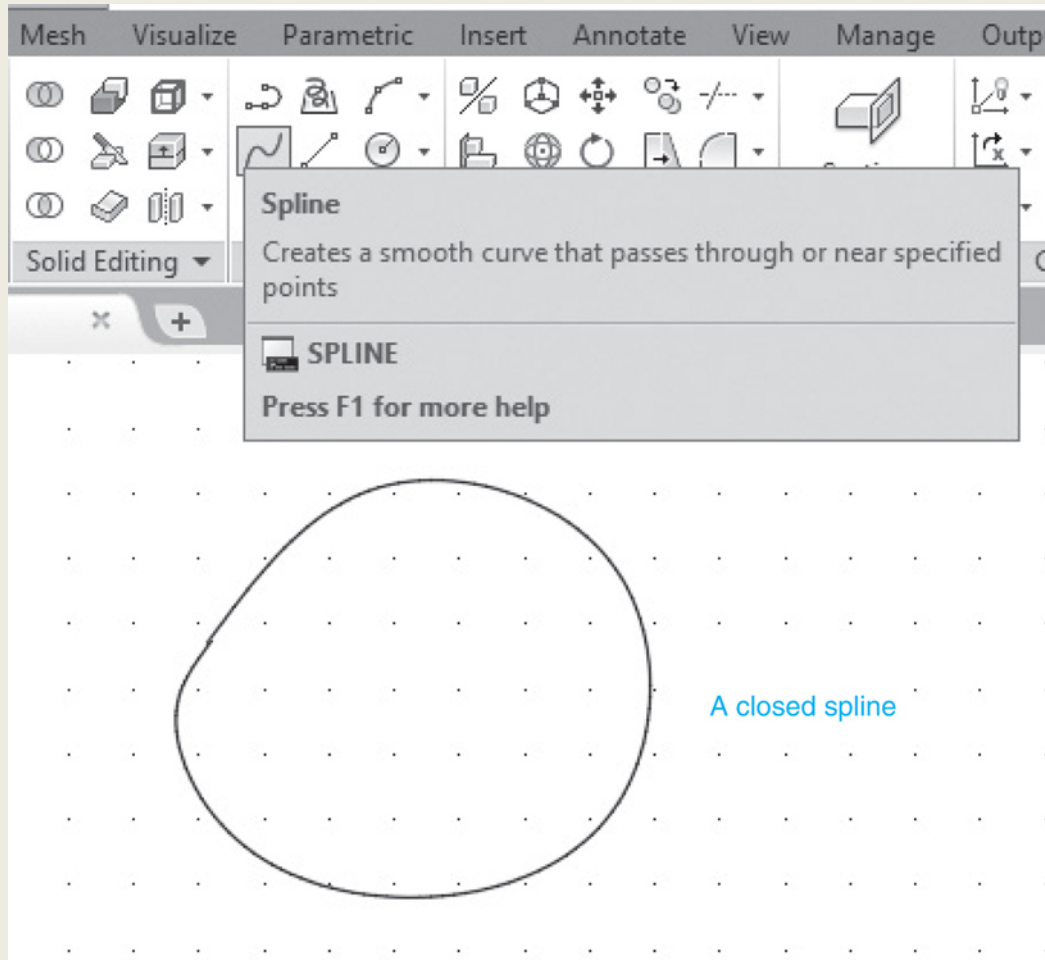



# Figure 2-25

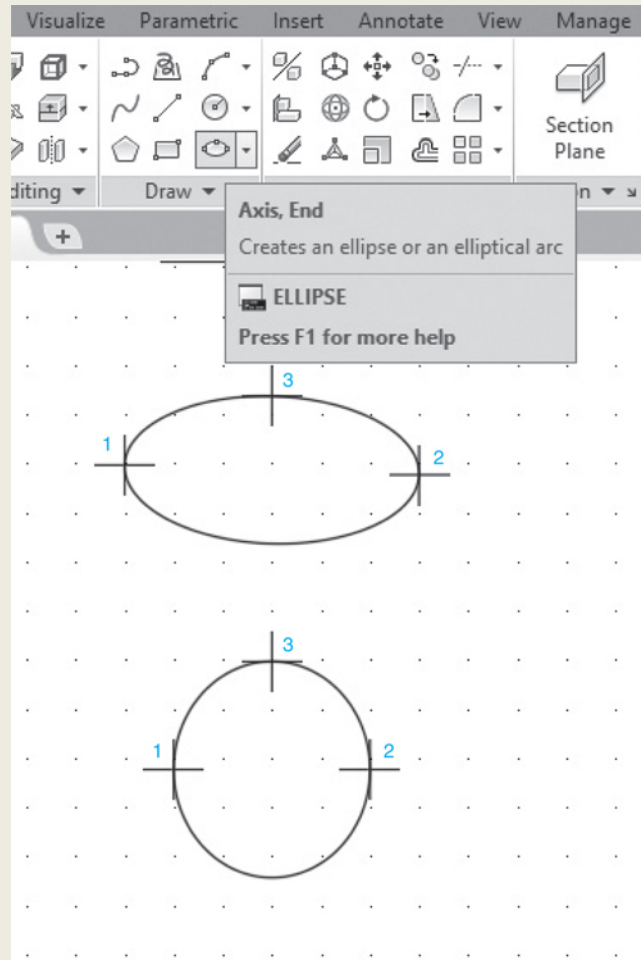

# Figure 2-26

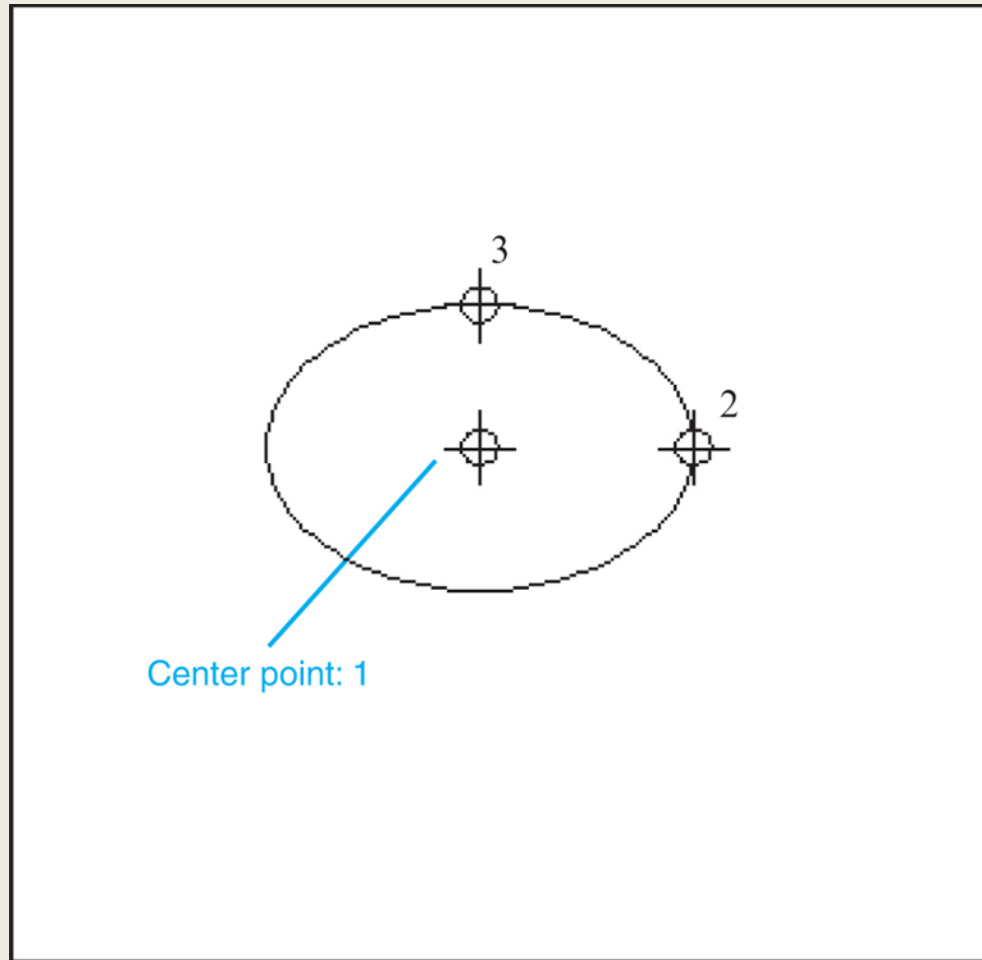

# Figure 2-27

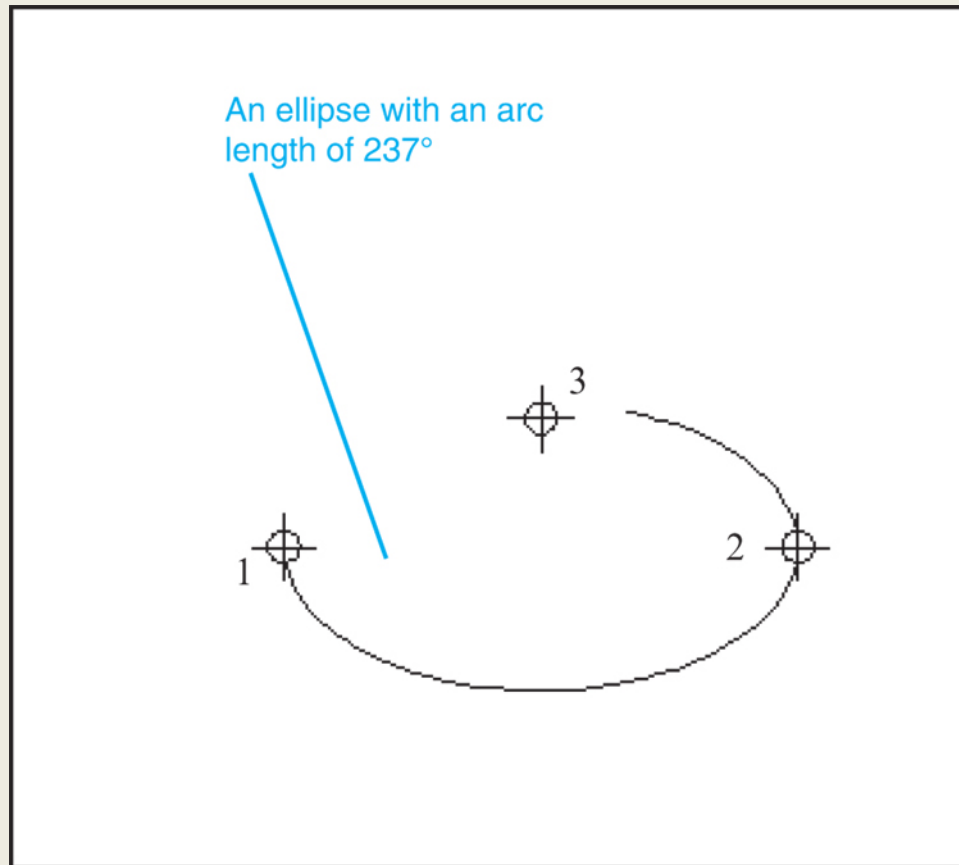

# Figure 2-28

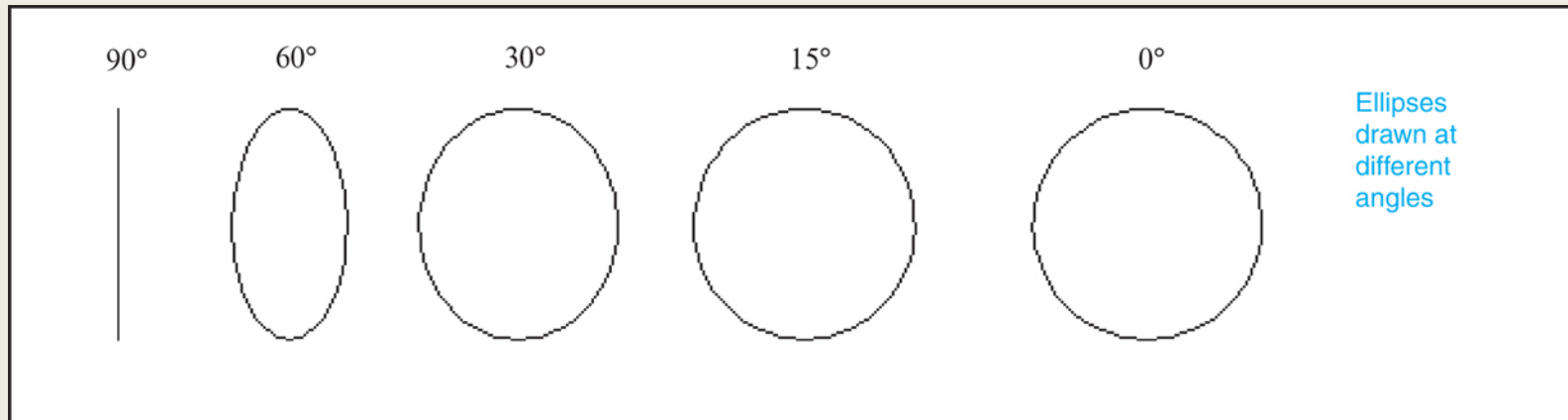

# Figure 2-29

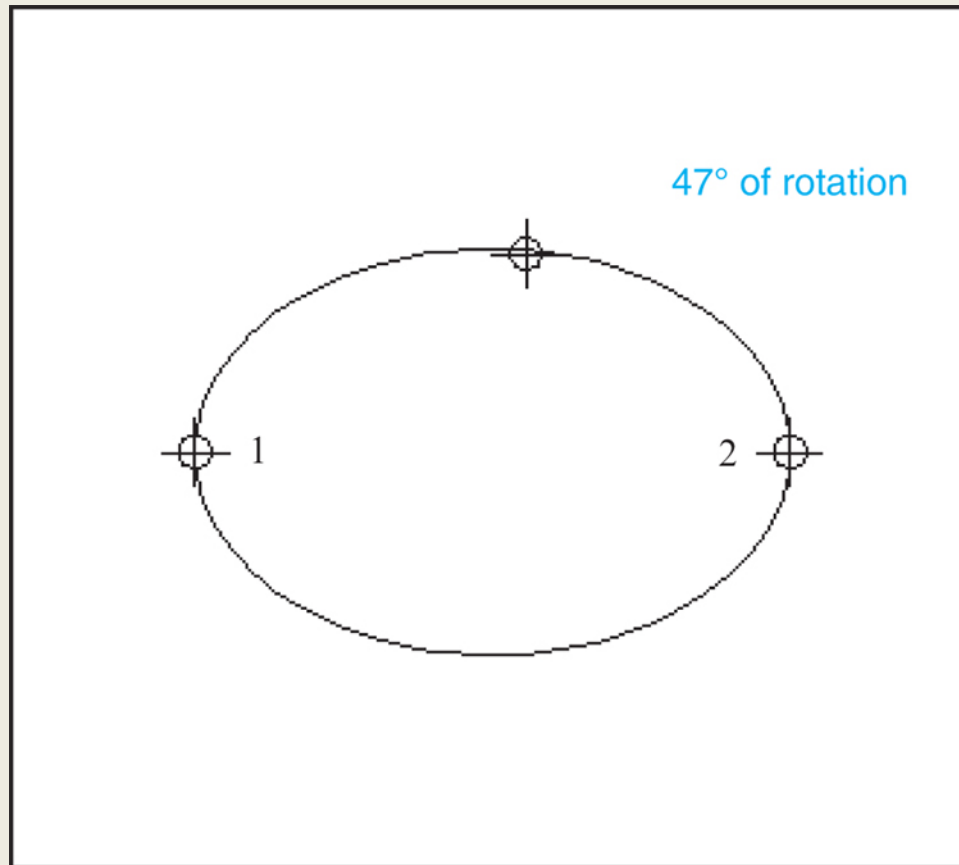

# Figure 2-30

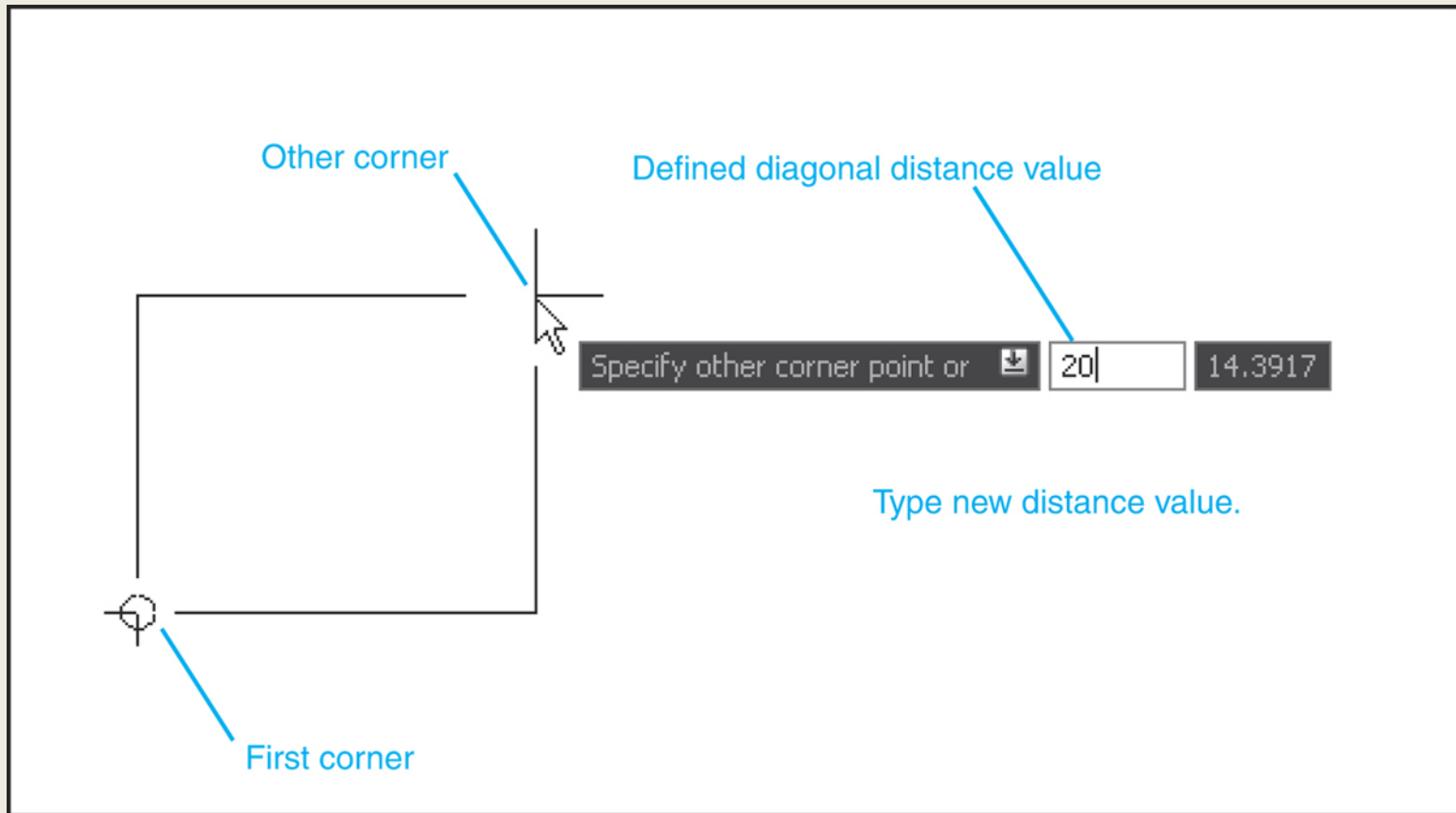

# Figure 2-31

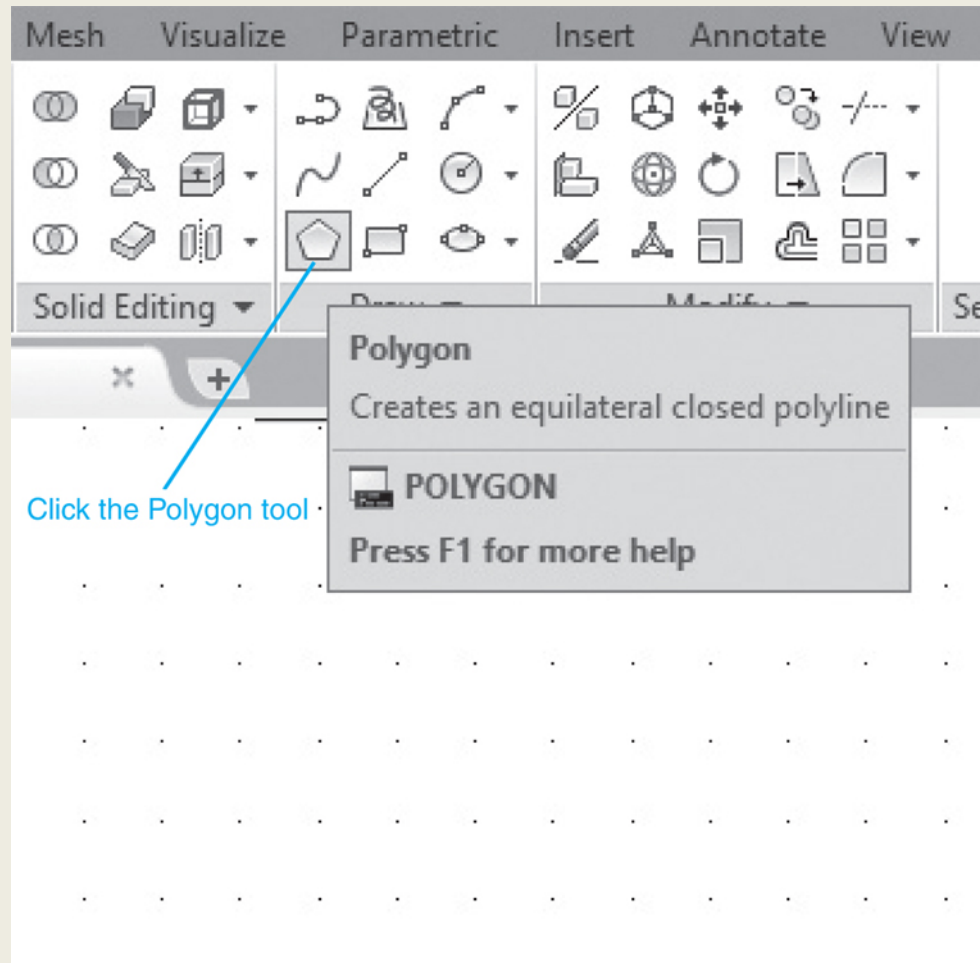

# Figure 2-31b

