

Panasonic

DVCPRO
DIGITAL VIDEO CASSETTE

Digital Video Cassette Player

AJ-D220 P

Operating Instructions

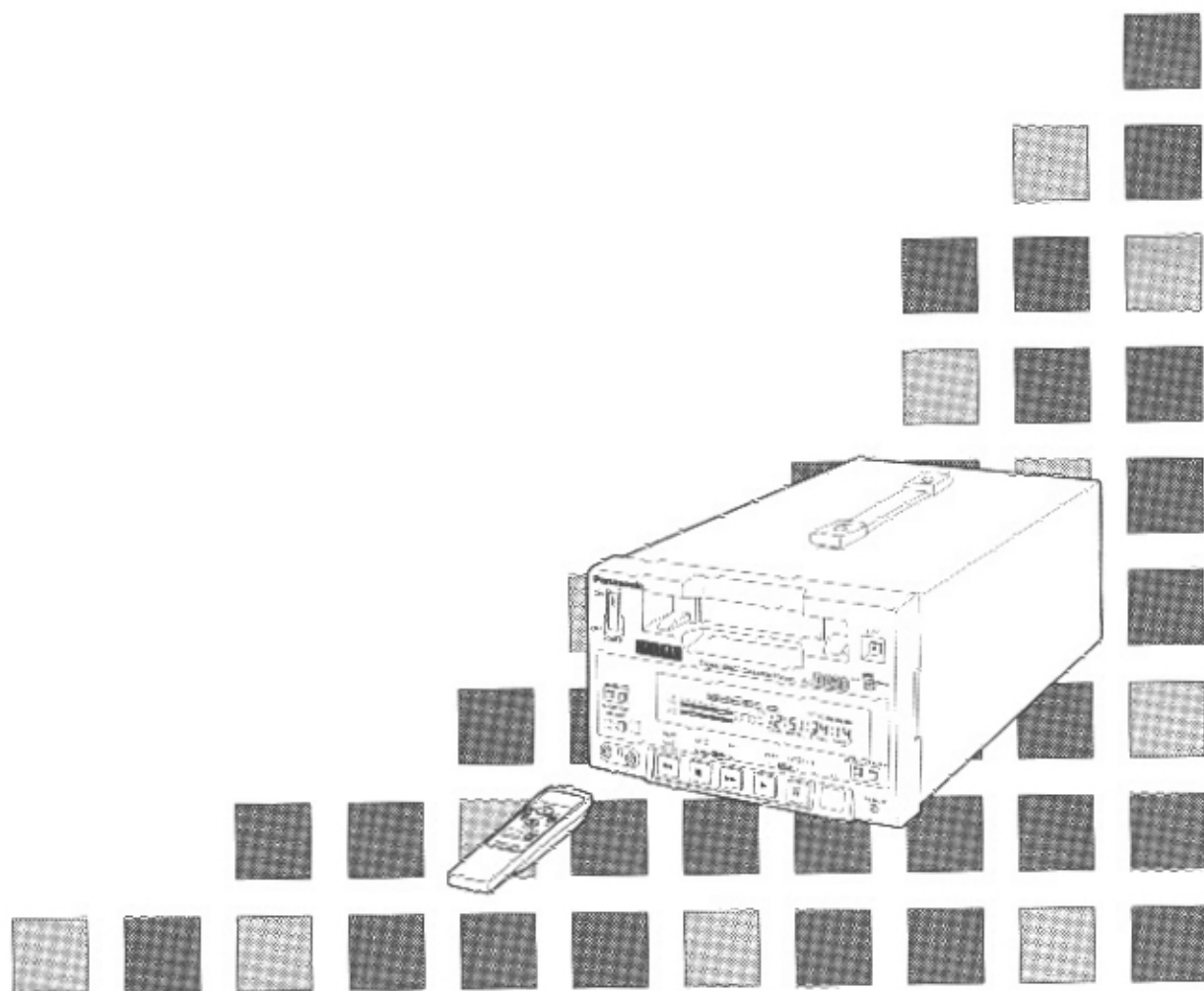



CAUTION
RISK OF ELECTRIC SHOCK
DO NOT OPEN



CAUTION: TO REDUCE THE RISK OF ELECTRIC SHOCK,
DO NOT REMOVE COVER (OR BACK).
NO USER SERVICEABLE PARTS INSIDE.
REFER TO SERVICING TO QUALIFIED SERVICE PERSONNEL.



The lightning flash with arrowhead symbol, within an equilateral triangle, is intended to alert the user to the presence of uninsulated "dangerous voltage" within the product's enclosure that may be of sufficient magnitude to constitute a risk of electric shock to persons.



The exclamation point within an equilateral triangle is intended to alert the user to the presence of important operating and maintenance (service) instructions in the literature accompanying the appliance.

WARNING:

TO REDUCE THE RISK OF FIRE OR SHOCK HAZARD, DO NOT EXPOSE THIS EQUIPMENT TO RAIN OR MOISTURE.

CAUTION:

TO REDUCE THE RISK OF FIRE OR SHOCK HAZARD AND ANNOYING INTERFERENCE, USE THE RECOMMENDED ACCESSORIES ONLY.

FCC Note:

This device complies with Part 15 of the FCC Rules. To assure continued compliance follow the attached installation instructions and do not make any unauthorized modifications. FCC's limits are designed to provide reasonable protection against harmful interference when operated in a residential environment. If this device does cause interference to radio or television reception, which can be determined by turning the device off and on, use this outlet different from that used by the receiver. If necessary, consult the dealer or an experienced radio/TV technician for help.

 is the safety information.

- Do not insert fingers or any objects into the video cassette holder.
- Avoid operating or leaving the unit near strong magnetic fields. Be especially careful of large audio speakers.
- Avoid operating or storing the unit in an excessively hot, cold, or damp environment as this may result in damage both to the unit and to the tape.
- Do not spray any cleaner or wax directly on the unit.
- If the unit is not going to be used for a length of time, protect it from dirt and dust.
- Do not leave a cassette in the unit when not in use.
- Do not block the ventilation slots of the unit.

- Use this unit horizontally and do not place anything on the top panel.
- Cassette tape can be used only for one-side, one direction playback. Two-way or two-track playback cannot be made.
- Cassette tape can be used for either Color or Black & White playback.
- Do not attempt to disassemble the unit. There are no user serviceable parts inside.
- If any liquid spills inside the recorder, have the unit examined for possible damage.
- Refer any needed servicing to authorized service personnel.

Table of Contents

Introduction	4
Features	4
Controls and Their Functions	5
● Front Panel	5
● Wireless Remote Controller	7
● Connector Section	8
Tapes	9
Operation	10
● Switching on the power and inserting the cassette	10
● Stop mode	11
● Playback	12
● Cue and Review	12
● Still-picture playback	12
● Frame advance	12
● Sound selection	13
● Repeat playback	14
Time Code and User's Bit	16
● Time code	16
● User's bit	16
● Time Code and User's Bit Playback	16
Superimposed Display Screens	17
Set-up (Default Settings)	18
● Changing a setting	18
Set-up Menus	19
● BASIC menu	19
● OPERATION menu	20
● MEMORY MODE menu	21
● TAPE PROTECT menu	21
● TIME CODE menu	22
● VIDEO menu	23
● AUDIO menu	23
Error Messages	24
Video Head Cleaning	25
Condensation	25
Maintenance	25
Specifications	26

Introduction

The model AJ-D220 is a playback-only digital VTR which uses 1/4-inch tapes.

It features digital compression technology which, compared with conventional analog systems, significantly reduces the deterioration in the picture and sound quality when tapes are played.

With its compact and lightweight design, the unit can be carried around with the greatest of ease, and it is also easy to install it in a rack.

An interactive format is used to perform the unit's settings while monitoring the menus on the screen of the TV monitor.

Features

Compact size and light weight

The unit measures 8-7/16" wide, 5-1/4" high and 15-7/16" deep, and it weighs only 15.4 lbs.

Grips are incorporated to make the unit easy to carry.

2-channel digital audio with high sound quality

Up to 123 minutes of playback

Either news-gathering cassette tapes (max. 63 minutes) or general-purpose cassette tapes (max. 123 minutes) can be used. In both cases, the tape is one-fourth of an inch wide to achieve a compact design.

Compatibility with consumer-use equipment

Consumer-use cassette tapes which have been shot using a consumer-use digital camera can be played back on this unit using the cassette adaptor (AJ-CS750P: option).

Please note that the LP mode is not supported.

Time code

This unit incorporates a time code reader (TCR).

Repeat playback

Repeat playback can be performed continuously or only once for any section of the tape.

Menu-driven set-up

An interactive system is used to perform the unit's settings while monitoring the menus appearing on the screen of the TV monitor.

Remote control

Remote control operations are possible using the wireless remote controller provided with the unit. Furthermore, connection of the AG-A11 remote controller (option) enables the unit to be operated from a distance of about 5 meters.

RF converter output (CH3, CH4)

Pictures can be monitored by connecting the unit to the ANT connector on the TV.

Controls and Their Functions

Front Panel

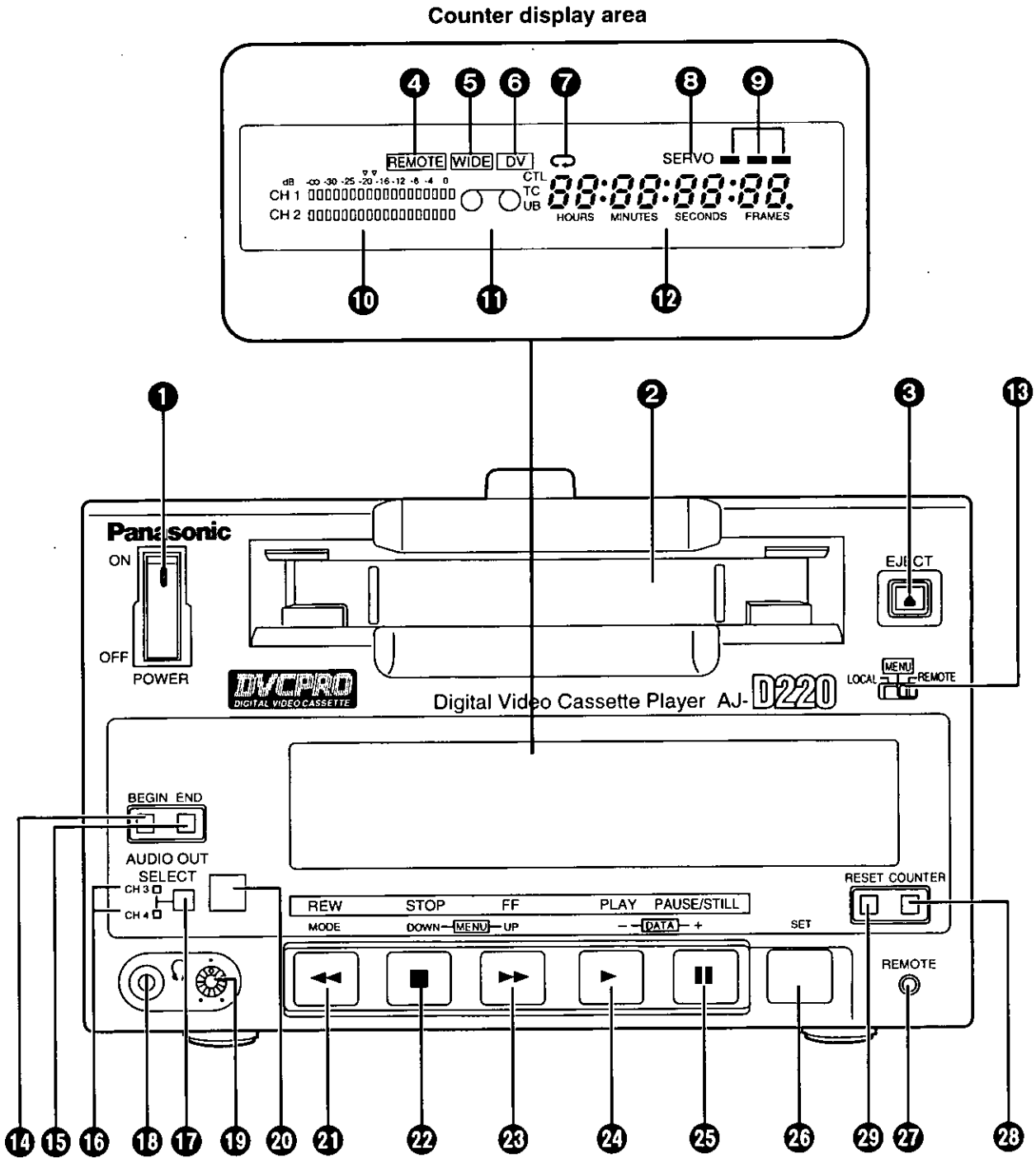

Controls and Their Functions

Front Panel

- 1 POWER switch**

When the ON side is pressed, the power is turned on, and the counter display area lights.
- 2 Cassette slot**

A news gathering cassette, general-purpose cassette or consumer-use cassette with an adaptor is loaded through this slot.
- 3 EJECT button**

When this is pressed, the tape is unloaded, and several seconds later the cassette is automatically ejected.
When the counter display area shows the CTL display, the display is now reset.
- 4 REMOTE lamp**

This lights when the LOCAL/MENU/REMOTE switch has been set to the REMOTE position.
- 5 WIDE lamp**

This lights in the 16:9 wide screen mode.
- 6 "Consumer-use cassette loaded" display lamp**

This lights when a cassette recorded on a consumer-use DV unit has been loaded.
- 7 REPEAT lamp**

This lights during repeat playback.
- 8 SERVO lamp**

This lights when the drum servo and capstan servo are locked.
- 9 Channel condition lamps**

One of these lamps lights (green → blue → red) in accordance with the status of the error rates.

Green: This lights when the error rates for the video and audio playback signals are both satisfactory.

Blue: This lights when the error rate for either the video or audio playback signals has deteriorated. The playback picture is still normal even while this lamp is lighted.

Red: This lights when either the video or audio playback signals are corrected or interpolated.
- 10 Level meter**

This displays the audio signal levels.
During playback, it displays the audio output signal levels.
- 11 "Cassette loaded" display lamp**

This lights when a cassette has been loaded into the unit.
- 12 Counter display area**

The TC and CTL counts, on-screen information and messages appear in this area.
- 13 LOCAL/MENU/REMOTE switch**

This is operated when menu settings are to be performed or when the unit is to be controlled from a remote location.

LOCAL: For controlling the unit using the controls on the unit's operation panel.

MENU: For setting the on-screen menu.

REMOTE: For controlling the unit using the remote controller.
- 14 BEGIN button**

This sets the repeat playback start point, and it displays the currently entered start point.
- 15 END button**

This sets the repeat playback end point, and it displays the currently entered end point.
- 16 CH3/CH4 lamp**

This lights during DV format playback when the audio signals have been set in CH3 and CH4.
- 17 AUDIO OUT SELECT button**

This selects the audio signals which are to be output.
- 18 Headphone jack**

When stereo headphones are connected here, the playback sound can be monitored through the headphones.
- 19 Volume control**

This is for adjusting the headphones volume.
- 20 Remote control sensor window**
- 21 REW button**

When this is pressed, the tape is rewound, and when "TAPE" is set for the "S/F/R BACK SEL" set-up menu item, the playback picture can be monitored.
- 22 STOP button**

When this is pressed, the tape stops traveling, and when "TAPE" is set for the "S/F/R BACK SEL" set-up menu item, the still picture can be monitored. Even in the stop mode, the drum continues to rotate with the tape kept in close contact with the drum. After the unit has been kept in the stop mode for a specific period of time, it is automatically set to the standby off mode in order to protect the tape. It is set to the stop mode immediately after a cassette has been loaded into the unit.
- 23 FF button**

When this is pressed, the tape is fast forwarded, and when "TAPE" is set for the "S/F/R BACK SEL" set-up menu item, the playback picture can be monitored.

Controls and Their Functions

24 PLAY button

When this is pressed, playback commences.

25 PAUSE/STILL button

When this is pressed during playback, the still picture mode is established. When it is pressed again, playback is resumed.

26 SET button

This is used to change a menu mode or default setting.

27 Remote control connector

When the remote controller (AG-A11) is connected to this connector, the unit can be operated from a distance by this controller instead of by its function buttons. In this case, the LOCAL/MENU/REMOTE switch must be set to the REMOTE position.

28 COUNTER button

This switches the display on the counter display area.

CTL: The tape timer (control signal) is displayed.

TC: The time code is displayed.

UB: The user's bit is displayed.

Remaining tape:

The amount of tape remaining is displayed.

29 RESET button

When this is pressed in the CTL mode, the counter display is reset to 00:00:00:00.

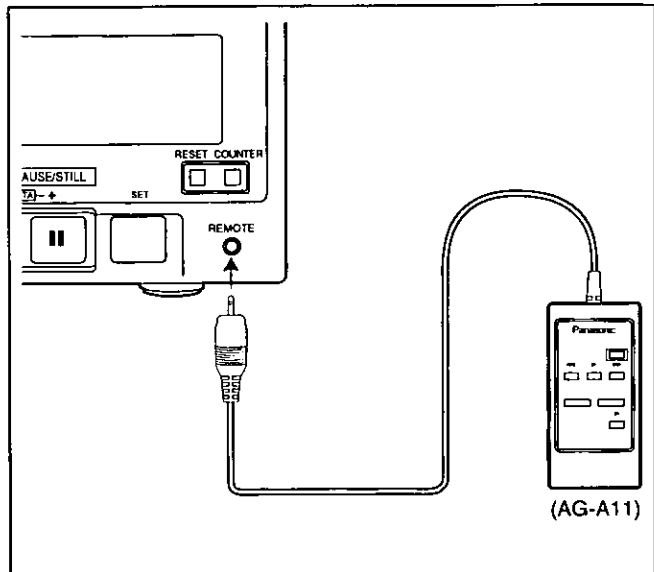

Wireless Remote Controller

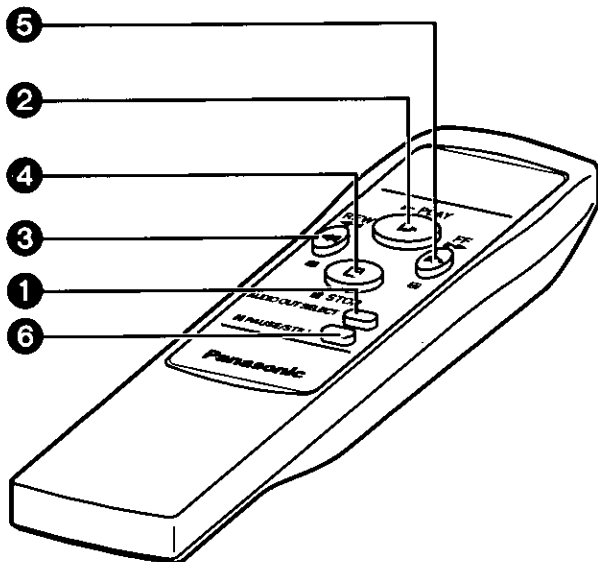

The function buttons on the wireless remote controller provided with this unit can be used in place of the unit's function buttons to operate the unit from a distance. Before using them for operation, however, the LOCAL/MENU/REMOTE switch must be set to the REMOTE position.

1 AUDIO OUT SELECT button

This selects the audio signals which are to be output.

2 PLAY button

When this is pressed, playback commences.

3 REW button

When this is pressed, the tape is rewound.

4 STOP button

When this is pressed, the tape stops traveling.

5 FF button

When this is pressed, the tape is fast forwarded.

6 PAUSE/STILL button

When this is pressed during playback, the still picture mode is established. When it is pressed again, playback is resumed.

Controls and Their Functions

Connector Section

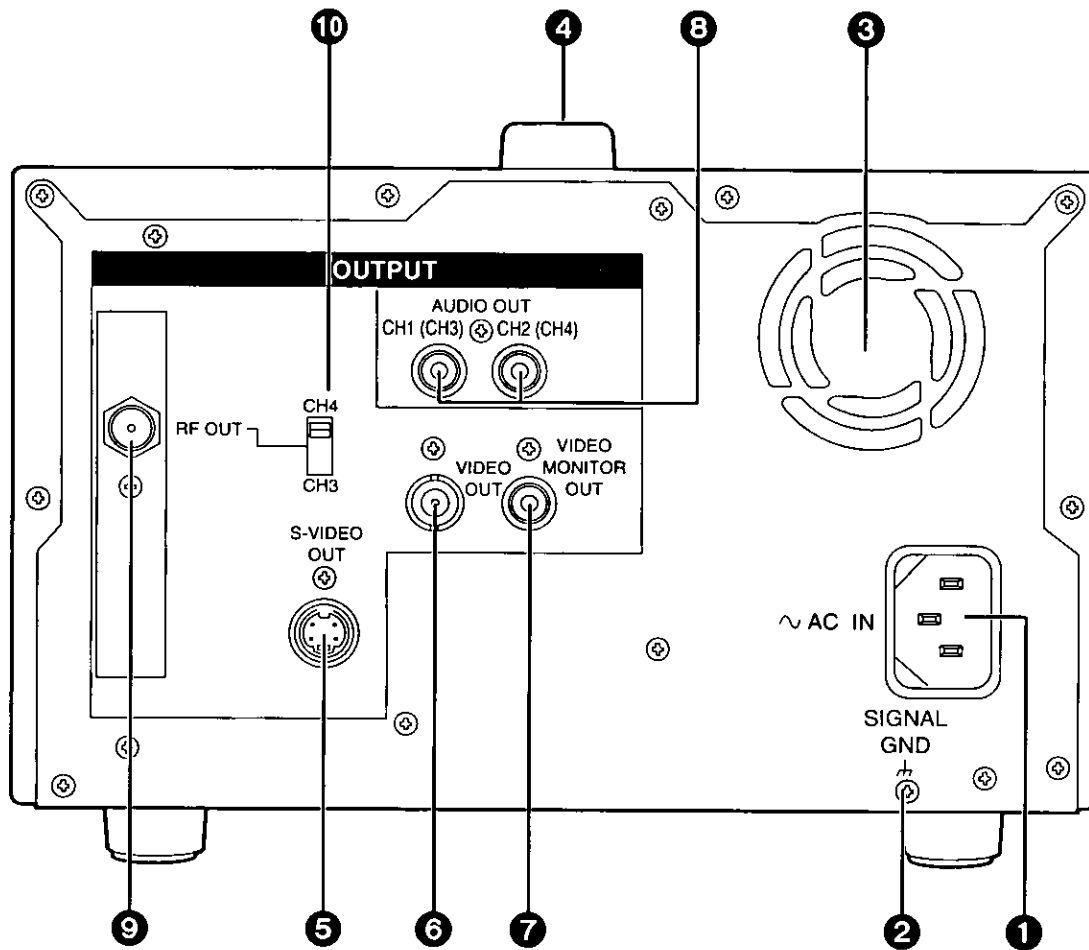

1 AC IN connector

Use the power cord supplied to connect this connector to the power outlet.

2 SIGNAL GND terminal

This is connected to the signal ground terminal on the unit connected in order to reduce the noise. It is not a safety ground.

3 Fan motor

This is for cooling the unit.

4 Handle

5 S-VIDEO OUT connector

This is the output connector for the S-VIDEO video signals.

6 VIDEO OUT connector

This is the output connector for the analog video signals.

7 VIDEO MONITOR OUT connector

This is the output connector for the video monitor signals.

Superimposed video signals can be output from it.

8 AUDIO OUT connector

This is the output connector for the analog audio signals.

9 RF converter output connector

Pictures can be monitored when this connector is connected to the ANT connector on the TV.

10 RF converter output selector switch (CH3/CH4)

Tapes

This unit is a playback-only digital VTR. It cannot be used for recording onto tapes.

Type	Description
Consumer-use cassette (S size cassette)	This is exclusively designed for use in consumer-use camera/recorder units. It can be used in the unit for playback only provided that the cassette adaptor (option) is obtained. Use of Panasonic consumer DV cassette tape is recommended. Note that inserting a cassette tape without using the cassette adaptor can damage the unit.
M size cassette	Playback tape with a maximum length of 63 minutes (AJ-P12MP, AJ-P23MP, AJ-P33MP, AJ-P63MP)
L size cassette	Playback tape with a maximum length of 123 minutes (AJ-P64LP, AJ-P94LP, AJ-P123LP)

Align the cassette tape with the center of the loading slot, and push it in gently. It will then be loaded automatically.

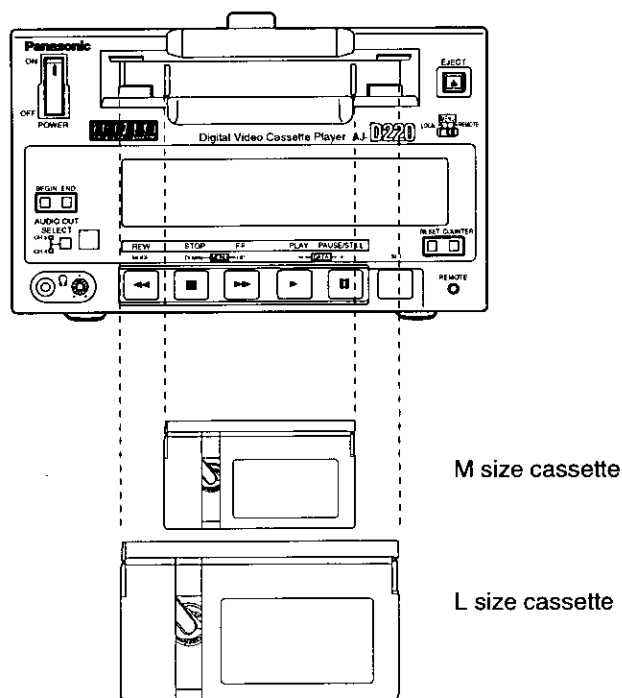

<Precautions for playing back consumer-use DV tapes>

- A consumer-use tape recorded in LP mode cannot be played back.
- The maximum traveling speed of a consumer-use tape is 32× normal tape speed.
- The still-picture images on a consumer-use tape may be disturbed.
- From the perspective of protecting the tape, refrain from cue-up operation using a consumer-tape wherever possible.
- When a consumer-use tape is employed, the maximum duration of the still timer is set to 10 seconds, and the total time during which the unit is allowed to be left standing in the still mode is set to 1 minute.
- The time code read disabled display may appear when a search is performed on a consumer-use tape or the still-picture image of such a tape is displayed.

Operation

Switching on the power and inserting the cassette

Before attempting to operate the unit, make sure that it has been connected properly.

- 1** Switch on the power.
Insert the power switch on the left side of the unit.
- 2** Insert the cassette tape.
Insert the cassette tape into its prescribed position without forcing it in any way.
- 3** Check that the STOP lamp has lighted.
When the tape is inserted, the cylinder starts rotating automatically, the tape is loaded, and the unit is set to the stop mode.

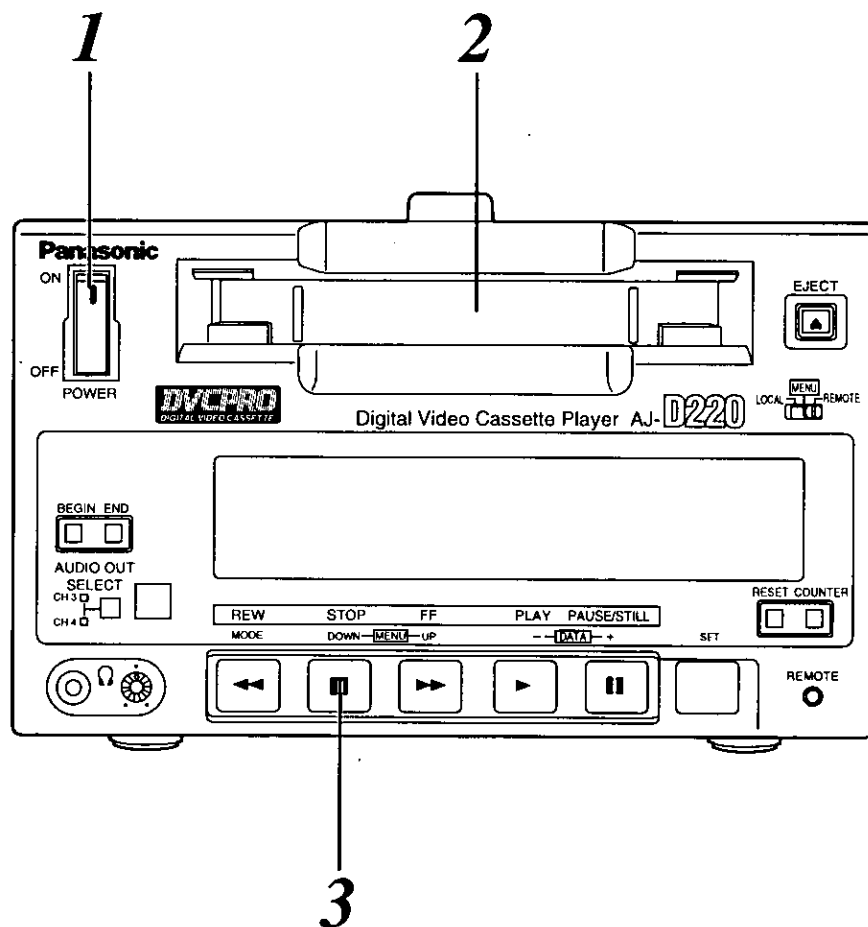

Operation

Stop mode

1 The unit is set to the stop mode when the STOP button is pressed. The STOP lamp lights and the tape stops traveling.

- In order to protect the tape, the unit is set to the tape protection mode after the period of time set in the "STILL TIMER" set-up menu item has elapsed. (See page 21) When the STOP, REW, FF or PLAY button is pressed, the unit is set to the corresponding mode.

<Precautions for setting the still timer>

- When the same part of the same tape is used repeatedly, the cumulative standby time in the same place increases. In order to protect the tape, set the standby time for the same place on the same tape to as short a duration as possible.

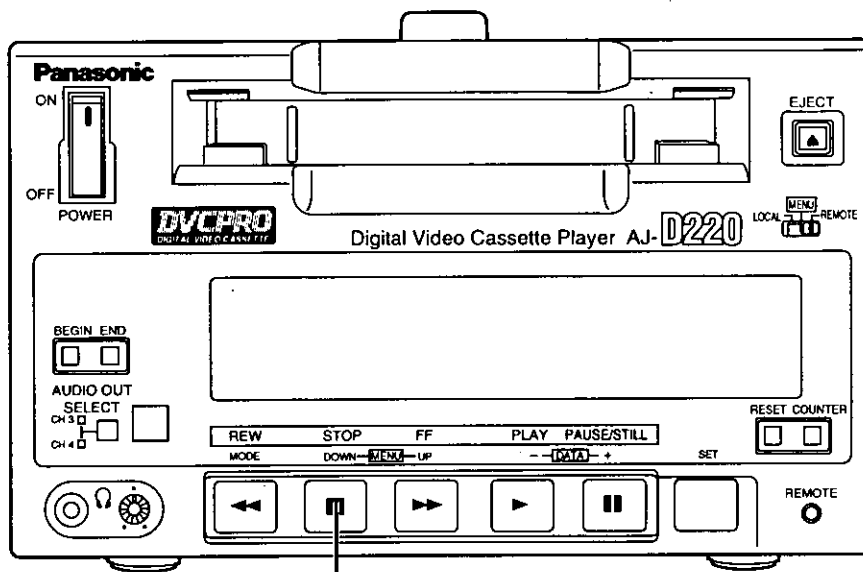

Operation

Playback

- 1** Insert the cassette tape.
- 2** Press the **PLAY** button.
Normal playback is now commenced.
- 3** To stop playback, press the **STOP** button.
The VTR is now set to the stop mode.

<Note>

- During playback, check that the **SERVO** lamp is lighted. If the lamp is off or flashing, the images played back will appear disturbed.

Cue and Review

Keep pressing the FF or REW button during playback.

While the button is held down, the tape is cued or reviewed at approximately 10× normal tape speed.

Normal playback is restored when the button is released.

- The cue track sound is output during cue or review if the "SEARCH CUE" set-up menu item has been set to ON. (See page 23)

Still-picture playback

**Press the PAUSE/STILL button during playback.
When it is pressed again, normal playback is restored.**

- No sound is heard during still-picture playback.

Frame advance

The tape is advanced or reversed frame by frame when the FF or REW button is pressed during still-picture playback.

- No sound is heard during frame advance or reverse.

Operation

Sound selection

Use the **AUDIO OUT SELECT** button to select the desired sound.

By pressing the AUDIO OUT SELECT button, the mode for the audio output is selected in the sequence shown below.

Mode	AUDIO OUT connectors		Display tube	LED
	CH1 output	CH2 output		
A	CH1	CH2	CH1 CH2	CH3 <input type="checkbox"/> CH4 <input type="checkbox"/>
B	CH1		CH1	CH3 <input type="checkbox"/> CH4 <input type="checkbox"/>
C	CH2		CH2	CH3 <input type="checkbox"/> CH4 <input type="checkbox"/>
D	CH3	CH4	No display	CH3 <input checked="" type="checkbox"/> CH4 <input checked="" type="checkbox"/>
E	CH3		No display	CH3 <input checked="" type="checkbox"/> CH4 <input type="checkbox"/>
F	CH4		No display	CH3 <input type="checkbox"/> CH4 <input checked="" type="checkbox"/>
G	CH1+CH3	CH2+CH4	CH1 CH2	CH3 <input checked="" type="checkbox"/> CH4 <input checked="" type="checkbox"/>

The shading denotes that the selection is valid only during playback using the DV format in the 4-channel mode.

.....Off
On

Sequence of mode selection

A → B → C → D → E → F → G

Operation

Repeat playback

Setting the BEGIN and END points [Menu mode]

- 1** Set the VTR to the menu mode.
(Set the LOCAL/MENU/REMOTE switch to the MENU position.)
- 2** Select the "BGN/END PRESET" set-up menu item, and press the MODE (REW) button. (See page 21)
- 3** Select TC or CTL using the COUNTER button.
- 4** Select either BGN or END using either the BEGIN button or the END button.
- 5** Select the digit (flashing display) in which the change is to be made using the UP (FF) and DOWN (STOP) buttons.
The frame digit cannot be selected. "00" is displayed for the frame value at all times.
- 6** Press the DATA+ (PAUSE/STILL) button or DATA- (PLAY) button to change the value.
- 7** Upon completion of the settings, press the SET button.
- 8** The settings are now stored in the memory, and the display returns to the regular menu screen.

<Notes>

- When an item has no setting, "--:--:--:--" is displayed.
When repeat playback is initiated in this status, the start of the tape serves as the BEGIN point and the end of the tape serves as the END point.
- When the RESET button is pressed, the setting is reset to "00:00:00:00."
- If the MODE (REW) button is pressed without pressing the SET button upon completion of the settings, the time code setting is canceled, and the display returns to the regular menu screen.
- When the BEGIN or END button is used to set the digit in which the change is to be made to BGN or END, and then the DATA+ or DATA- button is pressed, it is possible to select whether an item is to be set or left unset.

<Menu screen>

CTL	BGN	- 00 : 00 : 00 : 00
	END	+ 00 : 00 : 00 : 00

Operation

Setting the BEGIN and END points [Front panel]

- 1** Set the VTR to the local mode.
(Set the LOCAL/MENU/REMOTE switch to the LOCAL position.)
- 2** Press the BEGIN or END button on the front panel to set the current position as the BEGIN or END point.

Displaying the BEGIN and END points

- 1** Set the VTR to the remote mode.
(Set the LOCAL/MENU/REMOTE switch to the REMOTE position.)
- 2** When the BEGIN or END button on the front panel is pressed, the BEGIN or END point is displayed while the button is held down.

Setting the repeat playback mode

- 1** Set the VTR to the menu mode.
(Set the LOCAL/MENU/REMOTE switch to the MENU position.)
- 2** Select the "MEMORY MODE" set-up menu item, and select the repeat playback mode. (See page 21)

Setting	Description of operation
OFF	Normal operation
MEM STOP	When the tape is fast forwarded or rewound, it stops near the BEGIN point.
REPEAT 1	When the tape is played to the END point, it is rewound to the BEGIN point where it stops.
CONTINUE	When the tape is played to the END point, it is rewound to the BEGIN point and played back, and this sequence of operation is repeated.

<Notes>

- When the repeat play function is used over and over again for the same tape, the tape's images will deteriorate. Replace the tape with a new one after about a hundred repeat plays.
- Bear in mind that no operation will result when repeat play is to be performed using a consumer-use tape even if "CONTINUE" has been selected for set-up menu item No.300 (MEMORY MODE) (see page 21).

Time Code and User's Bit

Time code

The time code (signal) reader is used to read out the value of the time code so as to display the absolute position of the tape in increments of hours, minutes, seconds and frames.

The time code can be read out across a wide range of VTR playback speeds from the stop mode to slow playback and to high-speed playback.

The time code value appears on the display or it is indicated by figures superimposed onto the screen.

TCR	00	:	07	:	04	:	24
	↑		↑		↑		↑
	Hours		Minutes		Seconds		Frames

User's bit

The user's bit is a 32-bit (8-digit) information frame contained in the time code signals which is made available to the user.

Time Code and User's Bit Playback

1 Set the VTR to the STOP mode.

2 Set to TC or UB using the COUNTER button.

TC : The time code is displayed.

UB : The user's bit is displayed.

- When the time code can no longer be read, interpolation is provided by the control signal if the COUNTER button is set to the CTL position.

3 Press the PLAY button.

Playback is commenced, and the time code appears on the display. When the "DISPLAY SEL" set-up menu item is set to "TIME" or "T, STA," the time code value is superimposed onto the video signals which are output from the VIDEO MONITOR OUT connector.

(See page 19)

<Notes>

- The colon between the seconds and frames changes to a period while the drop frame time code is being read.
- If the time code signal is missing, interpolation is automatically provided by the CTL signal.

The display changes as shown below.

T * R 00 : 07 : 04 : 24

↑

↑

The colon (" : ") between the seconds and frames changes to a period (" . ") in the drop frame mode.

"*" appears when the time code signal is missing (superimposed display only).

Superimposed Display Screens

When the VIDEO MONITOR OUT connector has been connected to the TV monitor, the abbreviations corresponding to the control signal, time code, etc. are displayed on the TV monitor.

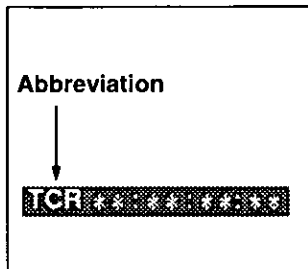

TV monitor

CTL (Control signal)
TCR (TC time code playback value)
UBR (TC user's bit playback value)
REMAIN (Remaining tape length)

Characters displayed

The background of the characters superimposed onto the display can be changed using the "CHARA TYPE" set-up menu item. (See page 19)

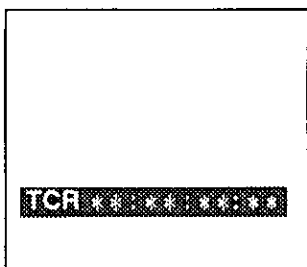

TV monitor

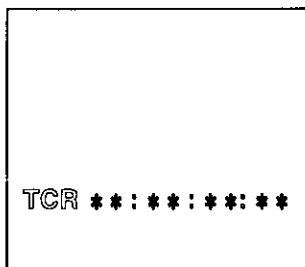

TV monitor

Display position

The position where the characters are superimposed onto the display can be changed using the "CHARA H-POS" and "CHARA V-POS" set-up menu items. (See page 19)

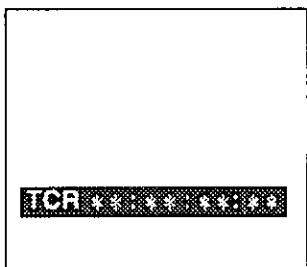

TV monitor

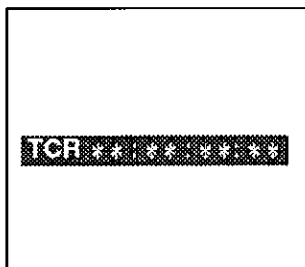

TV monitor

<Notes>

The counter display is made to appear for as long as the MODE button is held down, enabling the settings to be checked. Even while the MODE button is held down, the DATA+ and DATA- buttons can be used to perform settings while the actual situation is checked.

Operating mode

When "T, STA" has been selected for the "DISPLAY SEL" set-up menu item, the VTR's operating mode is also displayed. (See page 19)

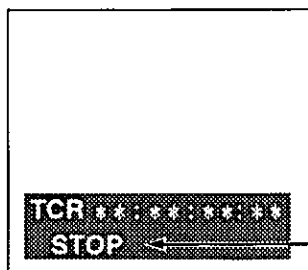

TV monitor

Set-up (Default Settings)

The VTR's major settings are performed by making selections using a menu system. The set-up menus appear on the TV monitor when it is connected to the VIDEO MONITOR OUT connector.

Changing a setting

- 1** Set the VTR to the menu mode.
(Set the LOCAL/MENU/REMOTE switch to the MENU position.)
- 2** Select the item to be set using the UP (FF) and DOWN (STOP) buttons. The cursor on the menu screen moves and selects the item.
The cursor (*) is moved to the previous set-up menu item number using the DOWN button and the next set-up menu item number using the UP button.
- 3** Press the DATA+ (PAUSE/STILL) button or DATA- (PLAY) button to change the setting.
- 4** Upon completion of the setting, press the SET button.
The change is now stored in the memory.

To return from the new setting to the original setting, set the LOCAL/MENU/REMOTE switch to the LOCAL or REMOTE position instead of pressing the SET button.

<Notes>

- To return the setup selections to the factory (default) settings, press the RESET button while the SETUP menu is shown. The following message is then displayed.

SETUP-MENU INIT. SET
OK? (PUSH SET KEY)

- The default settings will be restored when the SET button is pressed.

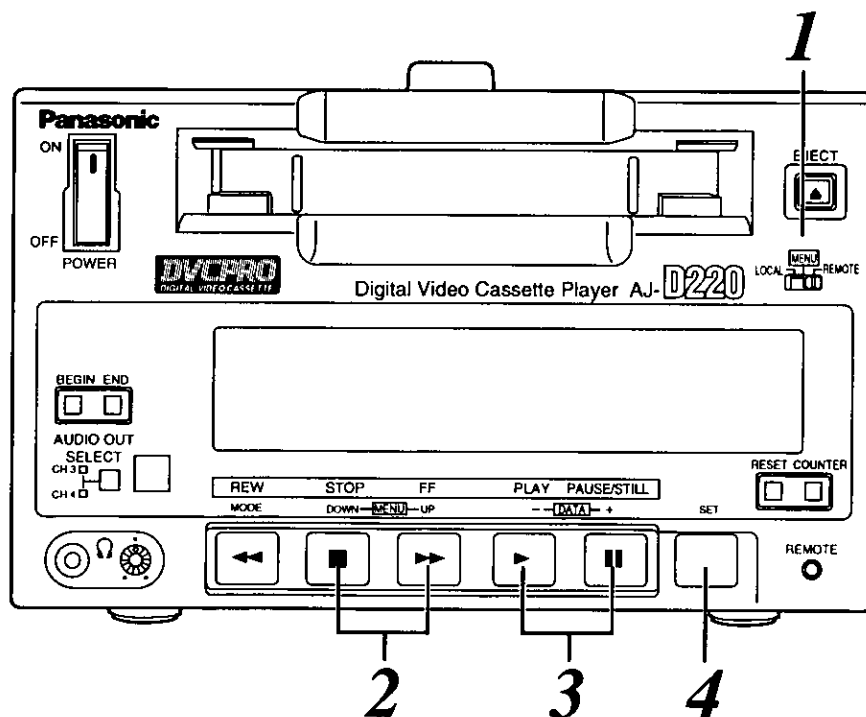

Set-up Menus

BASIC menu

Item		Setting		Description of settings
No.	Superimposed display	No.	Superimposed display	
000	DISPLAY SEL	<u>0000</u> 0001 0002	<u>OFF</u> TIME T, STA	This sets what is to be displayed for the superimpose signals output from the VIDEO MONITOR OUT connector. 0: No display 1: Only the time is displayed. 2: The time and operation mode are displayed.
001	CHARA H-POS	0000 0001 : <u>0003</u> : 0007	0 1 : <u>3</u> : 7	This sets the horizontal position of the superimposed characters (8 settings to choose from).
002	CHARA V-POS	0000 0001 : 0003 : <u>0007</u>	0 1 : 3 : <u>7</u>	This sets the vertical position of the superimposed characters (8 settings to choose from).
003	CHARA TYPE	<u>0000</u> 0001	<u>WHITE</u> W/OUT	This selects the type of characters for the superimposed display and menu display. 0: White characters appear on a black back ground. 1: White characters with black borders appear.

The underlined number and item are the factory settings.

<Note>

While setting "CHARA H-POS", "CHARA V-POS", and "CHARA TYPE", the counter display can be viewed by holding down the MODE button, allowing you to check the settings. You can also use the DATA+ and DATA- buttons while holding down the MODE button to adjust the values while you are viewing them.

Set-up Menu

OPERATION menu

Item		Setting		Description of settings
No.	Superimposed display	No.	Superimposed display	
100	LOCAL ENABLE	<u>0000</u> 0001	DISABLE <u>ST, EJ</u>	This selects the switches on the front panel which can be operated in the remote control mode. 0: None of the switches can be operated. 1: Only the STOP and EJECT switches can be operated.
101	TAPE TIMER	<u>0000</u> 0001	<u>12H</u> 24H	This selects the CTL counter display. 0: ±12-hour display 1: 24-hour display
102	S/F/R BACK SEL	<u>0000</u> 0001	<u>BLACK</u> TAPE	This selects the BLACK/VV output during stop, fast forwarding or rewinding. 0: BLACK is output. 1: VV is output.
103	WIDE MODE	<u>0000</u> 0001 0002	<u>AUTO</u> WIDE NORMAL	This selects the WIDE mode. 0: Automatic detection. 1: The screen mode is forcibly treated as WIDE. 2: The screen mode is forcibly treated as NORMAL.
104	TAPE IN MODE	<u>0000</u> 0001 0002 0003	<u>STOP</u> REW PAUSE PLAY	This selects the operation which follows when the cassette is inserted. 0: STOP 1: Rewind 2: Play pause 3: Play
105	TAPE END MODE	<u>0000</u> 0001 0002 0003	<u>STOP</u> REW REW→EJ EJECT	This selects the operation which follows when the tape has reached the end. 0: Stop 1: Rewind 2: This rewinds the tape and ejects it upon completion of rewinding. 3: Eject
108	FORMAT SEL	<u>0000</u> 0001 0002	<u>DVCPRO</u> DV DVCAM	This selects the format when an L cassette is used. 0: DVCPRO mode 1: DV mode 2: DVCAM mode

<Note>

The cassette tape is played back in one of the modes listed below depending on the tape type and settings used.

Type	FORMAT SEL setting		
	DVCPRO	DV	DVCAM
S size cassette	DV	DV	DVCAM
M size cassette	DVCPRO	DVCPRO	DVCPRO
L size cassette	DVCPRO	DV	DVCAM

Use tapes specially designed for DVCPRO applications with this unit. However, if DV tapes or DVCAM tapes are to be used in the playback mode, it is recommended that playback be limited to as short a period of time as possible.

The underlined number and item are the factory settings.

Set-up Menus

MEMORY MODE menu

Item		Setting		Description of settings
No.	Superimposed display	No.	Superimposed display	
300	MEMORY MODE	<u>0000</u>	<u>OFF</u>	This sets the memory operation. 0: No memory operation. 1: The tape stops near the BEGIN point when it is fast forwarded or rewound. 2: When the tape reaches the end, it is rewound to the BEGIN point where it stops. 3: When the tape reaches the end, it is rewound to the BEGIN point where it is played, and this process is repeated.
		0001	MEM STOP	
		0002	REPEAT 1	
		0003	CONTINUE	
301	BGN/END PRESET			This sets the BEGIN point and END point.

The underlined number and item are the factory settings.

TAPE PROTECT menu

Item		Setting		Description of settings
No.	Superimposed display	No.	Superimposed display	
400	STILL TIMER	0000	0.5S	This selects the time taken until the unit is set to the tape protection mode when it has been left standing in the stop, play pause or still mode. (Units: S = seconds, MIN = minutes)
		0001	5S	
		0002	10S	
		0003	30S	
		0004	1MIN	
		<u>0005</u>	<u>2MIN</u>	
401	SRC PROTECT	<u>0000</u>	<u>STEP</u>	This sets the tape protection operation which is performed when the unit has been left standing in the pause mode. 0: Step (step FWD in the pause mode) 1: Half loading (standby OFF)
		0001	HALF	

The underlined number and item are the factory settings.

<Notes>

- When using a consumer DV cassette tape, tape protection mode is set after 10 seconds, even if STILL TIMER is set to "30S", "1MIN" or "2MIN".
- When the unit is left in stop mode, the tape protection operation is always half loading (standby OFF).

Set-up Menus

TIME CODE menu

Item		Setting		Description of settings
No.	Superimposed display	No.	Superimposed display	
500	VITC POS-1	0000 0001 : <u>0006</u> : 0010	10L 11L : <u>16L</u> : 20L	This sets the position where the VITC signal is to be inserted. (The same line as that selected for VITC POS-2 cannot be selected.)
501	VITC POS-2	0000 0001 : <u>0008</u> : 0010	10L 11L : <u>18L</u> : 20L	This sets the position where the VITC signal is to be inserted. (The same line as that selected for VITC POS-1 cannot be selected.)
502	VITC BLANK	0000 <u>0001</u>	BLANK <u>THRU</u>	This sets whether the VITC signal is to be output. 0: VITC signal is not output. 1: VITC signal is output.
506	DF MODE	<u>0000</u> 0001	<u>DF</u> NDF	This selects the drop frame or non-drop frame mode for CTL. 0: CTL is used in the drop frame mode. 1: CTL is used in the non-drop frame mode.

The underlined number and item are the factory settings.

Set-up Menus

VIDEO menu

Item		Setting		Description of settings
No.	Superimposed display	No.	Superimposed display	
600	VIDEO MODE	0000 <u>0001</u>	B/W <u>COLOR</u>	For setting what video signals are to be used for playback. 0: For using monochrome signals. 1: For using color signals. ● To use monochrome signals for playback, set this item to the B/W mode. To use normal color signals, set it to the COLOR mode.
601	V-MUTE SEL	0000 <u>0001</u>	<u>N-MUTE</u> LOW-RF	This selects whether the video signals are to be muted during playback under low RF conditions or when the servo lock is disengaged. 0: Video signals are not muted. 1: Video signals are muted.
602	CC (F1) BLANK	0000 <u>0001</u>	BLANK <u>THRU</u>	This selects ON or OFF for the closed capture signal in the first field. 0: Signal is forcibly blanked. 1: Signal is not blanked.
603	CC (F2) BLANK	0000 <u>0001</u>	BLANK <u>THRU</u>	This selects ON or OFF for the closed capture signal in the second field. 0: Signal is forcibly blanked. 1: Signal is not blanked.

The underlined number and item are the factory settings.

AUDIO menu

Item		Setting		Description of settings
No.	Superimposed display	No.	Superimposed display	
700	SEARCH CUE	0000 <u>0001</u>	OFF <u>ON</u>	This selects whether the cue audio signals are to be output during search or during fast forwarding/rewinding (VV). 0: Signals are not output. 1: Signals are output.
701	DV PB ATT	0000 <u>0001</u>	OFF <u>ON</u>	This selects the audio output level during DV format playback. 0: Normal playback level 1: Output level is controlled only during DV format playback.
702	PB MUTE	0000 <u>0001</u>	OFF <u>ON</u>	This selects whether the sound is to be muted during playback at the tag recording points. 0: Sound is not muted. 1: Sound is muted. However, it may not be possible to mute the sound at the edit OUT point.

The underlined number and item are the factory settings.

Error Messages

When trouble has occurred in the VTR, one of the following messages appears on the tape counter.

However, the VTR will continue to operate.

Error No.	Description of error
— d —	Condensation has formed.
E — 00	This appears when the servo has been disengaged for 3 seconds during normal playback.
E — 01	This appears when dropouts have been detected for two or more seconds during normal playback.
E — 11	The reel base which operates in accordance with the size of the tape has been locked for more than 2.5 seconds.
E — 21	The cassette has not moved down even when 4 seconds have elapsed since it was inserted. Alternatively, the cassette is not ejected even when 4 seconds have elapsed since the EJECT button was pressed.
E — 31	The loading operation was not completed within 4 seconds.
E — 32	The unloading operation was not completed within 4 seconds.
E — 41	The FG (rotational speed) signal has not been output from the cylinder motor.
E — 42	The PG (phase) signal has not been output from the cylinder motor.
E — 43	The rotational speed of the cylinder motor is abnormally high.
E — 44	The rotational speed of the cylinder motor is abnormally low.
E — 51	The FG (rotational speed) signal has not been output from the capstan motor.
E — 52	The rotational speed of the capstan motor is abnormally high.
E — 53	The rotational speed of the capstan motor is abnormally low.
E — 61	The supply reel motor has locked up.
E — 62	The take-up reel motor has locked up.
E — 63	The rotational speed of the supply reel motor is abnormally high.
E — 64	The rotational speed of the take-up reel motor is abnormally high.
E — 65	A tension error has been detected.
E — 66	The start or end processing operation has not been completed even though 7 or more seconds have passed.
E — 67	Communication error between SERVO and AVSYS. There is an error in the data.
E — 68	Communication error between SERVO and AVSYS. The data has been fixed at high or low.
E — 69	An error occurred in communication between SERVO and AVSYS when the power was turned on.
E — 70	The fan motor stopped operating.
E — 80	Trouble has occurred in the supply voltage.

Video Head Cleaning

This VTR comes with an auto head cleaning function which automatically reduces the amount of dirt on the heads. However, to ensure the highest reliability, we recommend that you clean the video heads every day.

Use the cleaning fluid designated by Panasonic.

Checking the hour meter

- 1** Set the VTR to the remote mode.
(Set the LOCAL/MENU/REMOTE switch to the REMOTE position.)
- 2** When the RESET button on the front panel is pressed, the cumulative numbers of hours during which the drum and capstan have been used are indicated alternately on the counter display for as long as the button is held down.

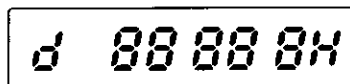

Cumulative drum rotation time

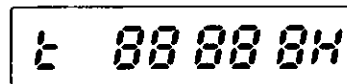

Cumulative capstan rotation time

Condensation

The principle according to which condensation forms is the same as that which causes droplets of water (condensation) to form on the window panes of a heated room when it is cold outside. Condensation forms on the VTR or its tape when it is moved to a location with a considerably different temperature and humidity. More specifically, it forms when the VTR or tape is:

- Brought into a very steamy and humid location or into a room where the heating was just turned on.
- Brought suddenly from an air-conditioned room to a very hot and humid location.

In such cases, do not turn the power on straight away but leave the unit standing for about 10 minutes. When condensation has formed in the unit, an error message lights up in the counter display section, and the cassette tape is automatically ejected.

Keep the power on and wait until the error message is cleared.

Maintenance

Before performing any maintenance work, set the power switch to the OFF position and disconnect the power cable from the AC outlet making sure that you take hold of the molded part of the power plug.

Use a soft cloth to clean the cabinet. In order to get rid of stubborn dirt, dilute some neutral kitchen detergent with water, dip a cloth into the solution, wring it out well, and wipe away the dirt. Then wipe off any moisture which remains using a dry cloth.

Do not use paint thinners or benzine for cleaning purposes.

Specifications

GENERAL

Power supply:	120 V AC, 50Hz-60Hz
Power consumption:	37 W

Ambient operating temperature:	41°F to 104°F (5°C to 40°C)
Ambient operating humidity:	35% to 85% (no condensation)
Weight:	15.4 lbs. (7.0 kg)
Dimensions (W × H × D):	8-7/16" × 5-1/4" × 15-7/16" (214 × 132 × 391 mm)
Format:	DVCPRO
Tracks:	Digital video
Time code:	Playback in sub-code area
Digital audio:	2 channels
Cue track:	1 track
Control (CTL):	1 track
Tape speed:	33.820 mm/sec.
Playback time:	123 minutes (using AJ-P123LP tape) 63 minutes (using AJ-P63MP tape)
Tape used:	1/4" thin magnetic layer metal tape
FF/REW time:	Within 3.5 min. (using AJ-P123LP tape)

VIDEO

(Digital video)	Sampling frequency:	13.5 MHz for Y; 3.375 MHz for Pb/Pb
	Quantizing:	8 bits
	Error correction:	Reed-Solomon product code
(Line OUT)	Video band:	30 Hz to 4.5 MHz (0 ±2.0 dB) for Y
	Y/C delay:	Less than 20ns
	K factor:	Less than 3%
(Output connectors)	Analog composit output:	BNC × 1; 1.0 V _{P-P} , 75 Ω
	Monitor output:	Phono × 1; 1.0 V _{P-P} , 75 Ω (superimpose on/off)
	S-VIDEO:	4P × 1; Y: 1.0 V _{P-P} , 75 Ω C: 0.286 V _{P-P} , 75 Ω (burst level)

AUDIO

(Digital audio)	Sampling frequency:	48 kHz
	Quantizing:	16 bits
	Frequency response:	20 Hz to 20 kHz (+0 dB, -2.0 dB)
	Dynamic range:	More than 80 dB (1 kHz, emphasis OFF, "A" weighted)
	Distortion:	Less than 0.2% (1 kHz, emphasis OFF, reference level)
	Crosstalk:	Less than -80 dB (1 kHz, between 2 channels)
	Wow and flutter:	Below measurable limits
(Output connectors)	Analog output (CH1/CH2):	Phono × 2; -8 dBV, 1 kΩ
	Headphones output:	M3 stereo, variable level (max. -32 dBV or more), 8Ω

OTHER INPUT/OUTPUT CONNECTORS

RF output (CH3/CH4):	VIDEO, AUDIO
Wired remote control:	M2 jack (simple remote control)

DISPLAY TUBE

Counter:	8 digits (CTL/TC/UB selectable, remaining tape)
Audio level meter:	18 steps
Other:	REMOTE, WIDE, "Consumer-use cassette loaded" display, REPEAT, SERVO, Channel condition, "Cassette loaded" display

Specifications

ACCESSORIES

AC power cord ×1

Wireless remote controller ×1

Dry batteries for wireless remote controller "AA" (R06) ×2

Weight and dimensions shown are approximate.
Specifications are subject to change without notice.

Panasonic

Broadcast & Television Systems Company

Division of Matsushita Electric Corporation of America

Executive Office

One Panasonic Way (4B-7), Secaucus, NJ 07094

Service Centers

Eastern: One Panasonic Way, Panazip (2A-4), Secaucus, NJ 07094
(201)-348-7677 Fax (201)-348-7511

Southern: 1225 Northbrook Parkway, Suite #170, Suwanee, GA 30174
(770)-338-6855 Fax (770)-338-6656

Western: 4001 West Alameda Ave., Suite 100, Burbank, CA 91505
(818)-562-1579 Fax (818)-562-6663

Parts Information & Ordering

9:00 am – 5:00 pm (EST) (800)-334-4881/24 hr.Fax (800)-334-4880

Technical Support

Emergency 24 hr Parts & Support (800)-222-0741

Training Information

Digital System Products (201)-392-6076

Service Literature

(201)-392-6281

Panasonic Canada Inc.

5770 Ambler Drive, Mississauga, Ontario L4W 2T3 (905)-624-5010

Panasonic de Mexico S.A. de C.V.

Av angel Urraza Num. 1209 Col. de Valle 03100 Mexico, D.F. (52) 1 951 2127

Printed in Japan
VQT7440

S1197W-100 Ⓐ



This file has been downloaded from:

www.UsersManualGuide.com

User Manual and User Guide for many equipments like mobile phones, photo cameras, monther board, monitors, software, tv, dvd, and othes..

Manual users, user manuals, user guide manual, owners manual, instruction manual, manual owner, manual owner's, manual guide, manual operation, operating manual, user's manual, operating instructions, manual operators, manual operator, manual product, documentation manual, user maintenance, brochure, user reference, pdf manual