

DIEGO ORTEGA

ADV. DETAILING STUDIO

SPRING 2014 (MIDTERM)

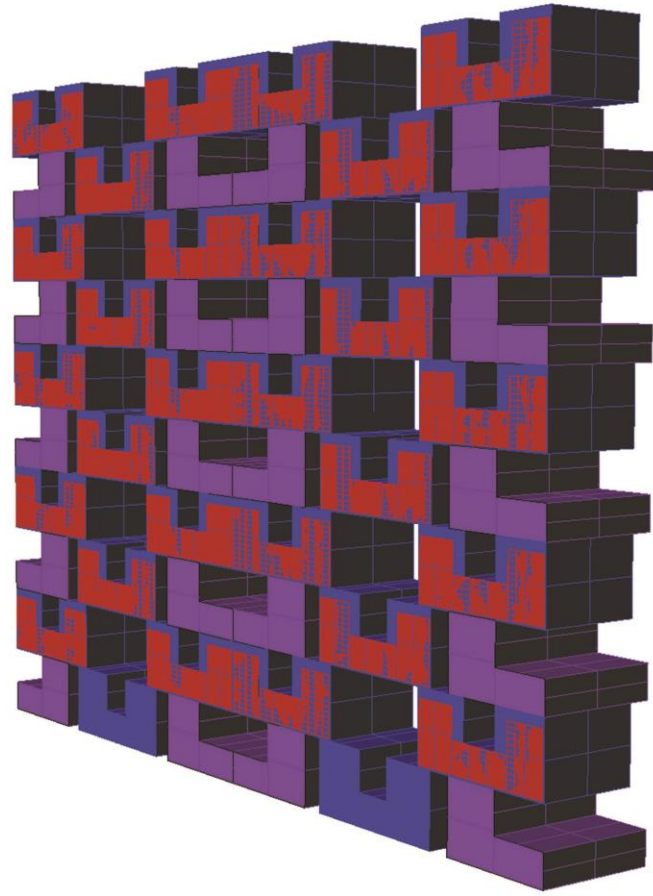

MODULE OF 50 UNITS

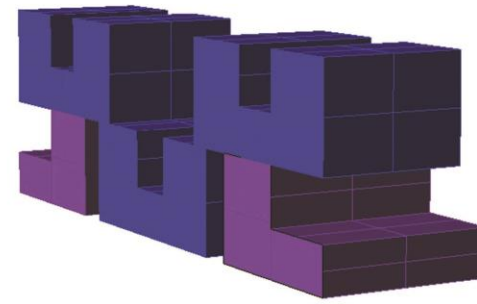

MODULE OF 5 UNITS

MODULE UNITS

ADVANCED DETAILING STUDIO
DIEGO ORTEGA

SOUTH ELEVATION

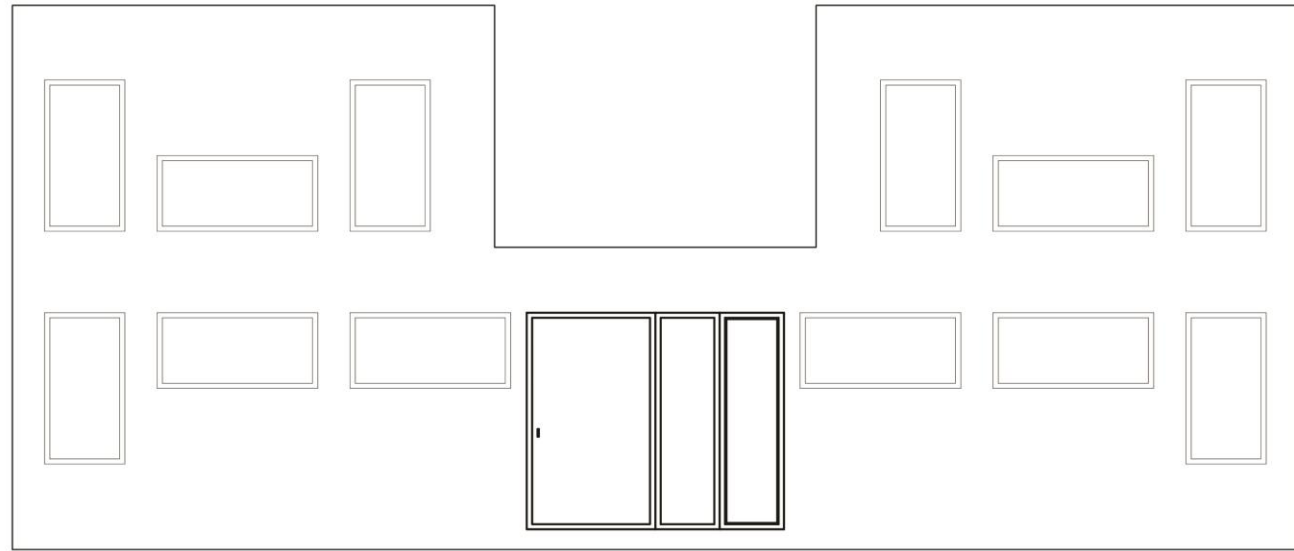

SECOND FACADE

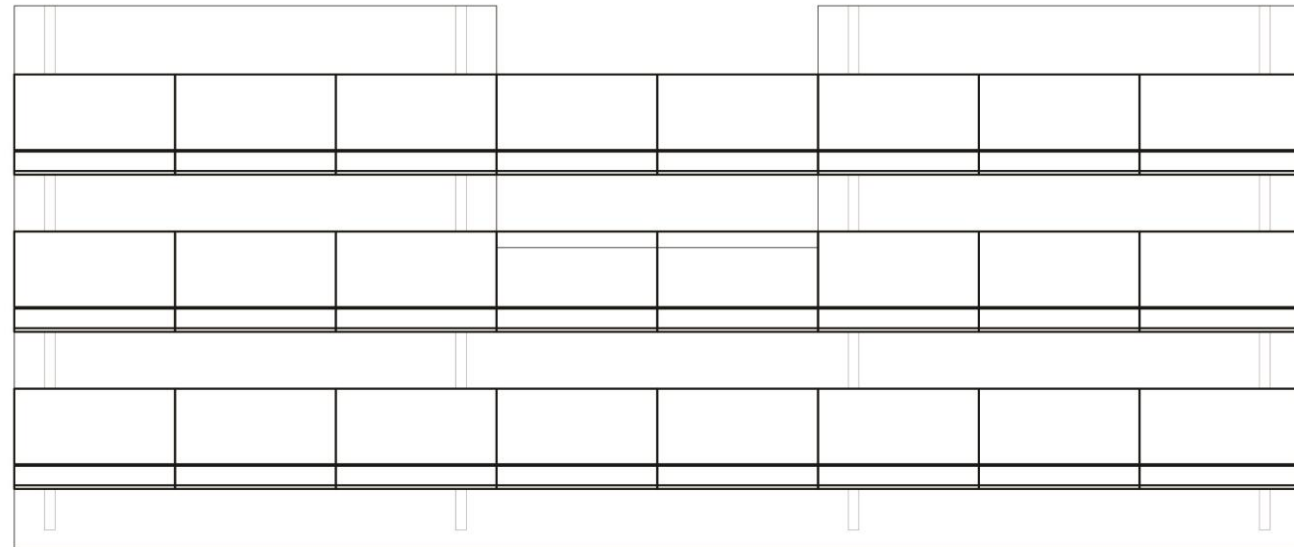

SUSTAINABLE LIVING

ADVANCED DETAILING STUDIO
DIEGO ORTEGA

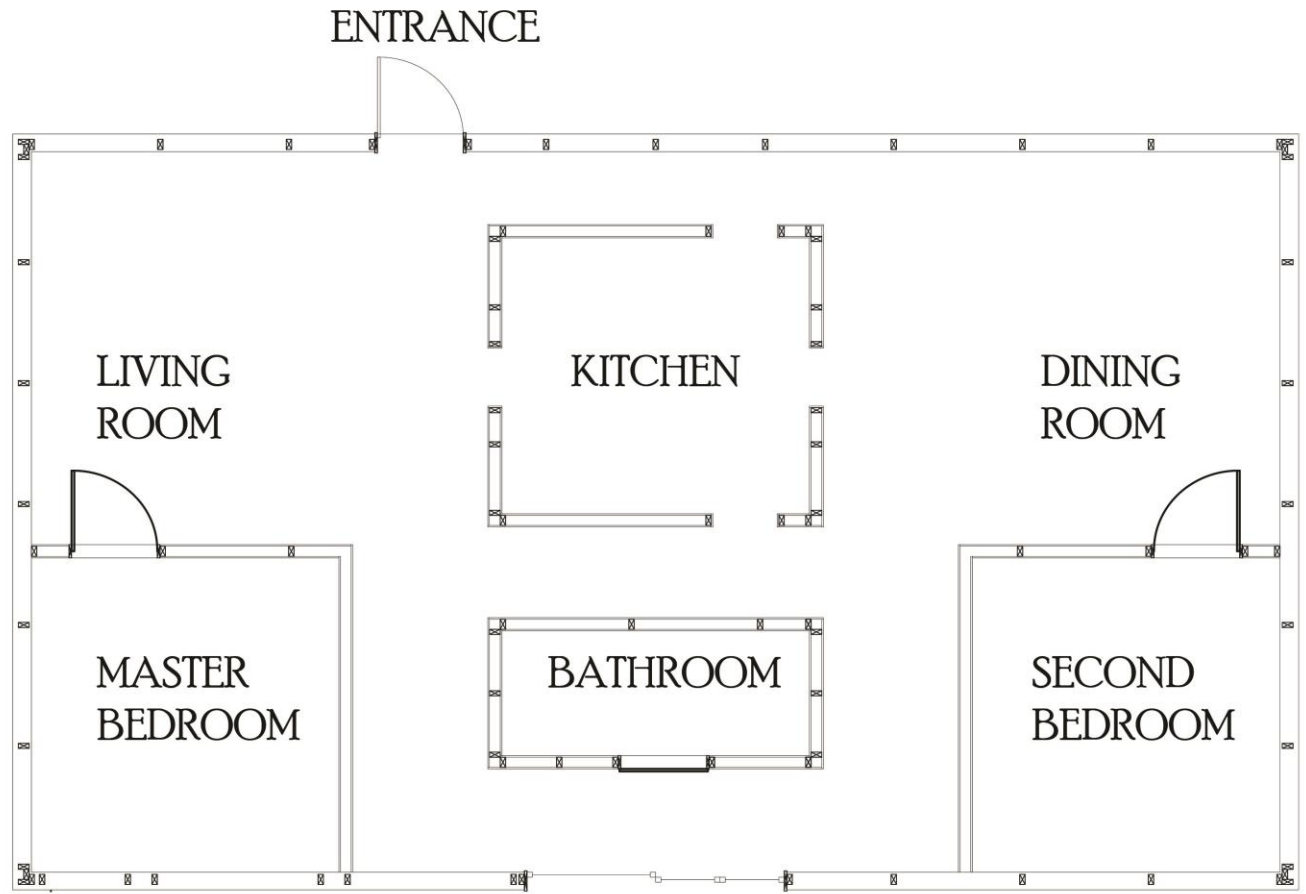

FLOORPLAN WITHOUT
SECOND FACADE

SOUTH ELEVATION

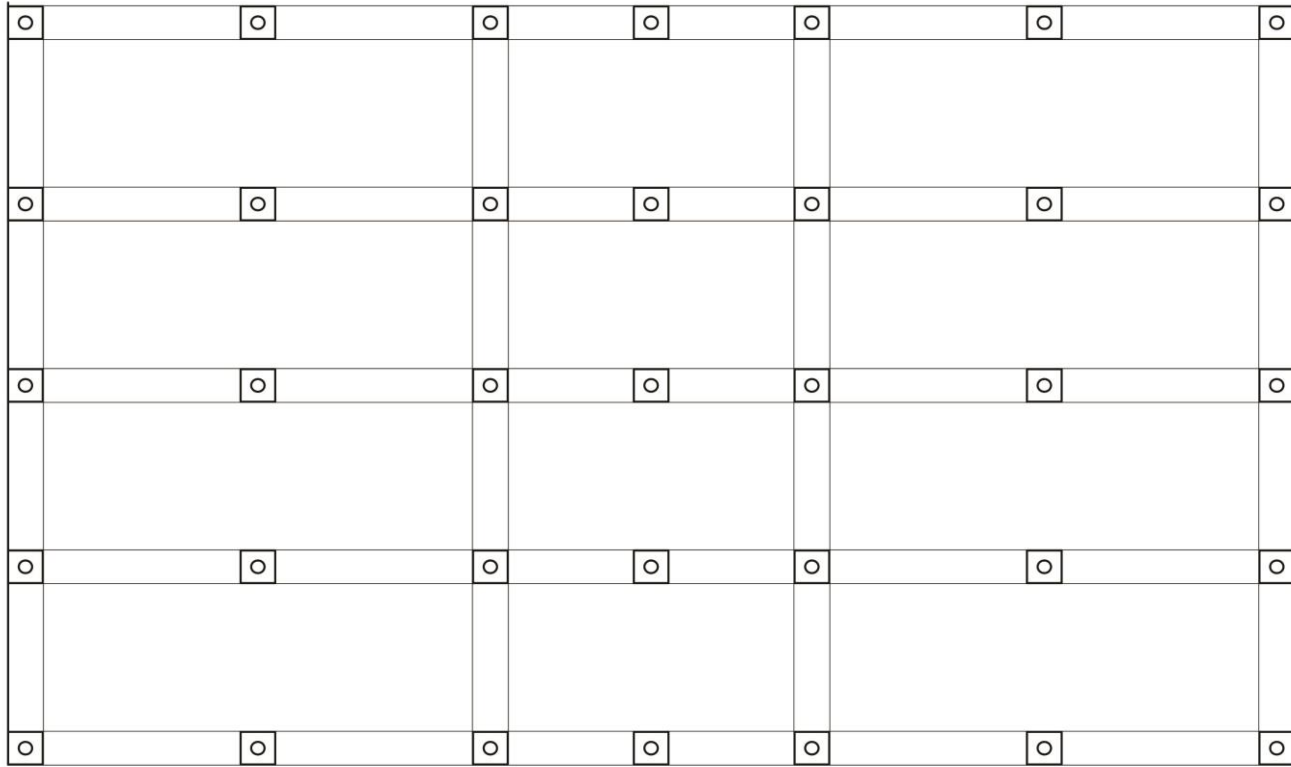

STRUCTURAL PLAN

SOUTH ELEVATION

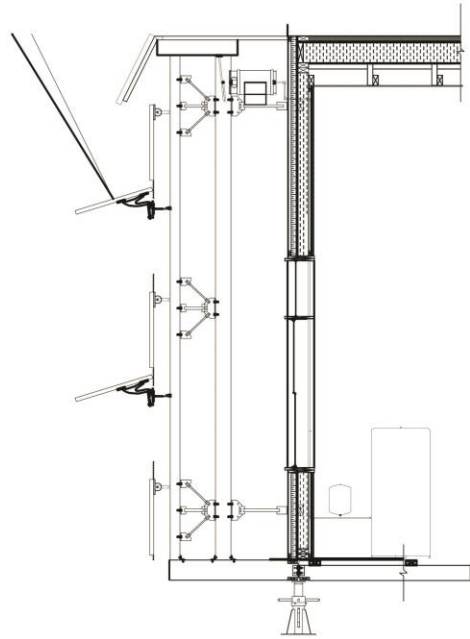

SUMMER SOLSTICE

SCALE: 3/8"=1'

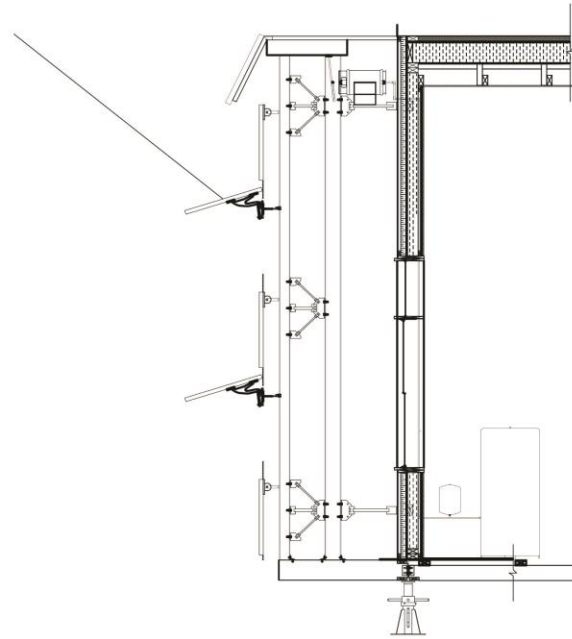

WINTER SOLSTICE

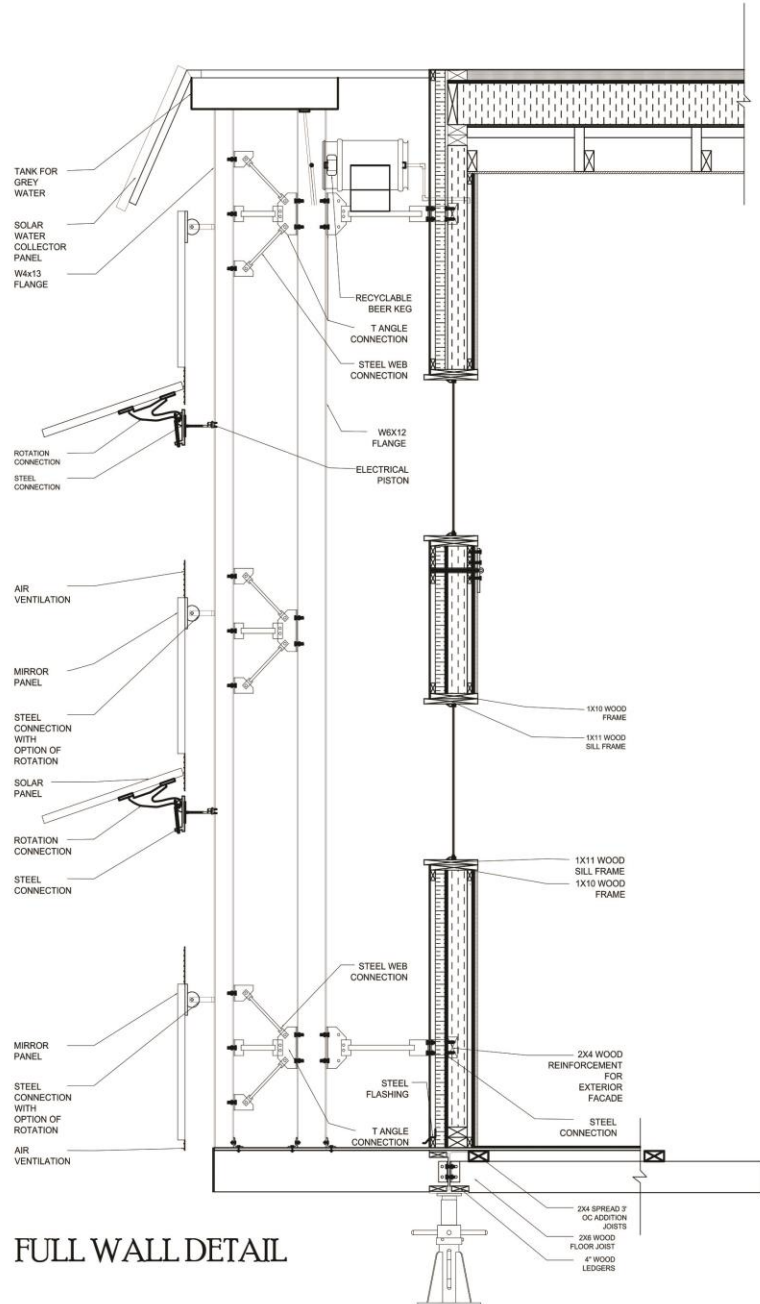

FULL WALL DETAIL

WALL DETAILS

ROOF DETAIL

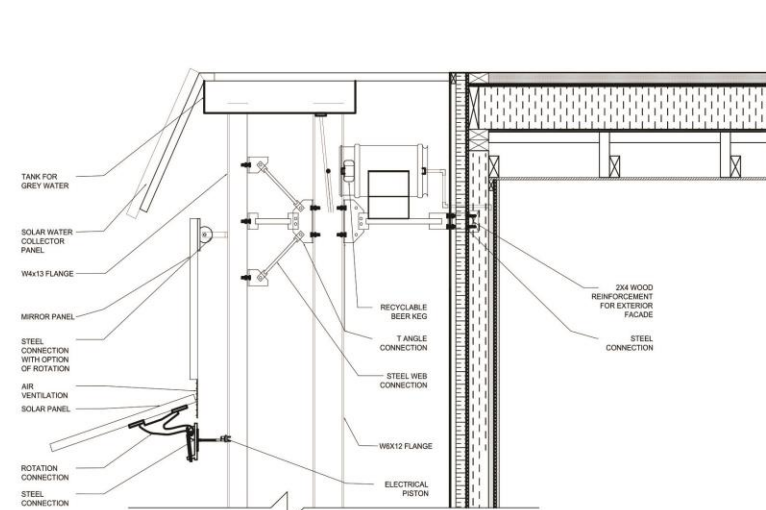

WINDOW DETAIL

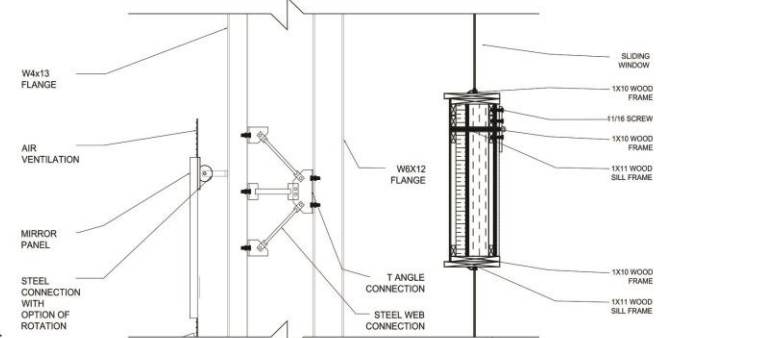

FLOOR DETAIL

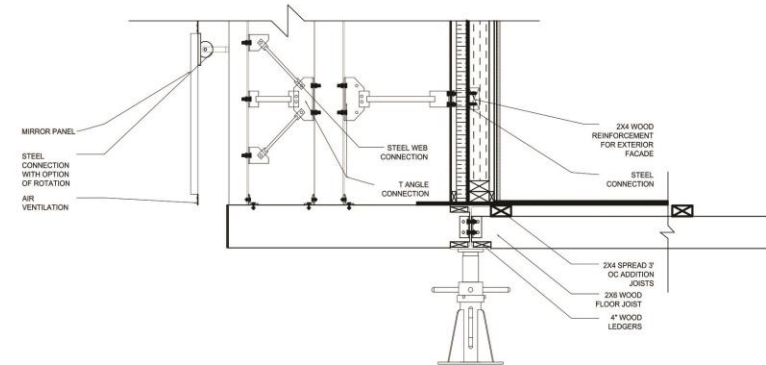

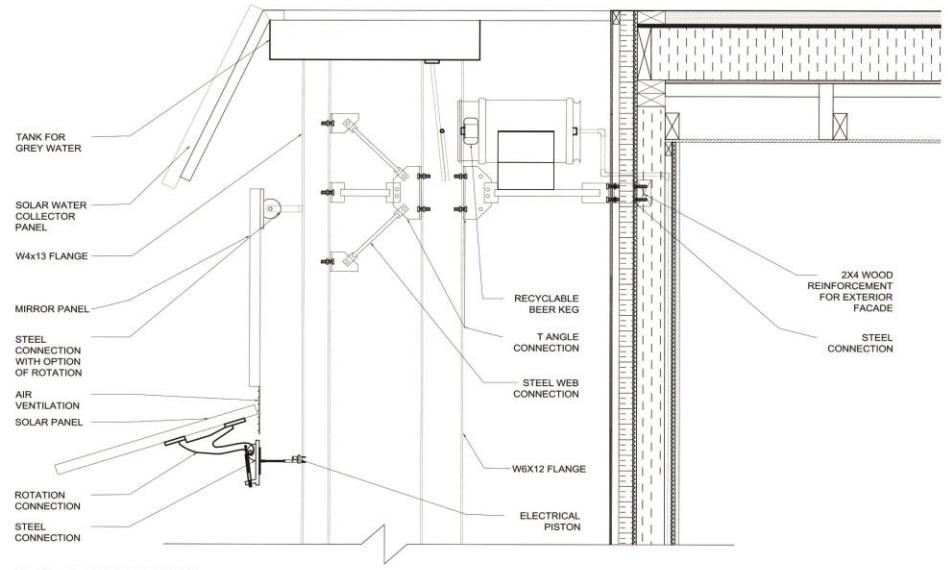

ROOF DETAIL

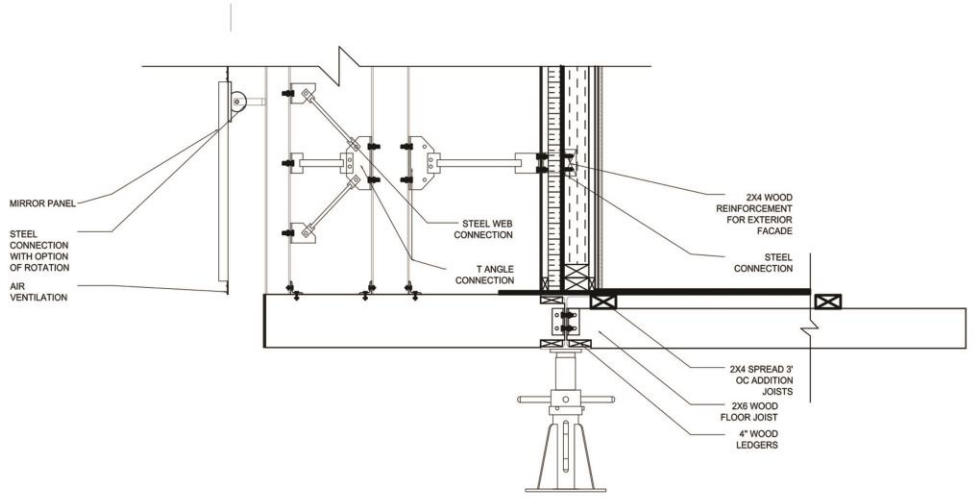

FLOOR DETAIL

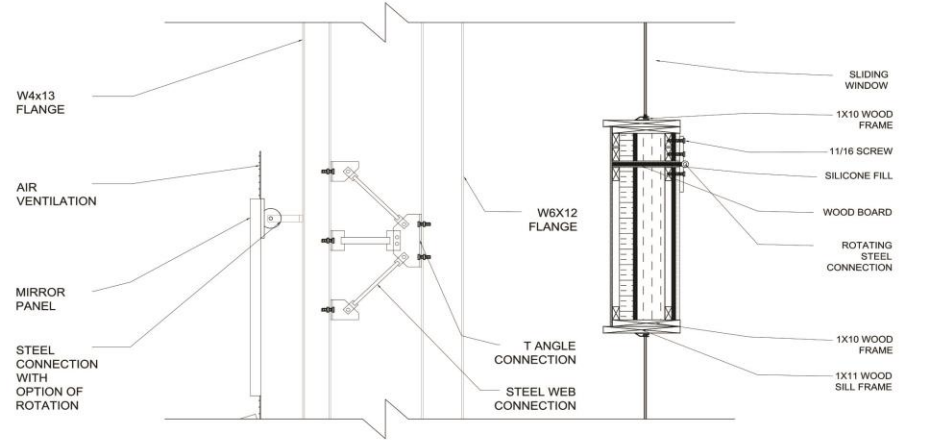

WINDOW DETAIL

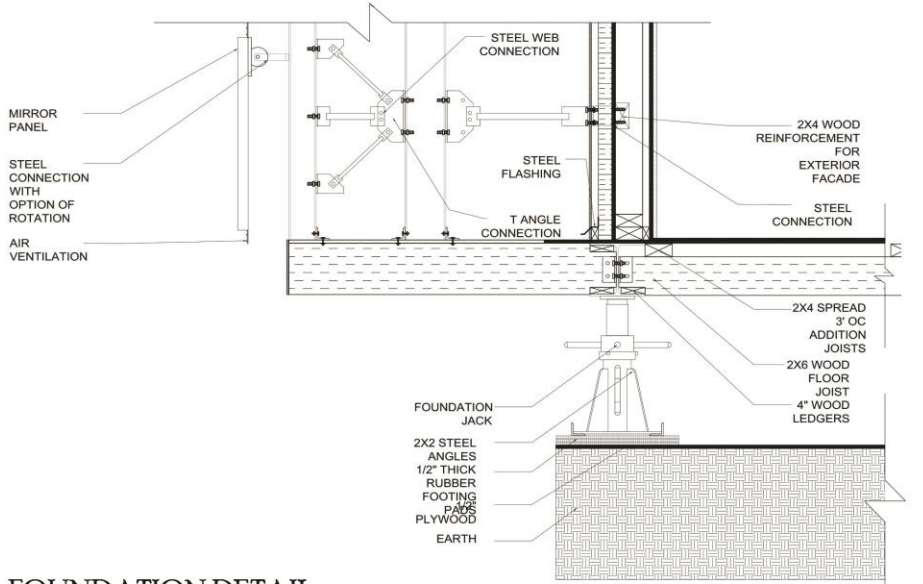

FOUNDATION DETAIL

CALLOUT DETAILS