

solidwork model
- imported surface

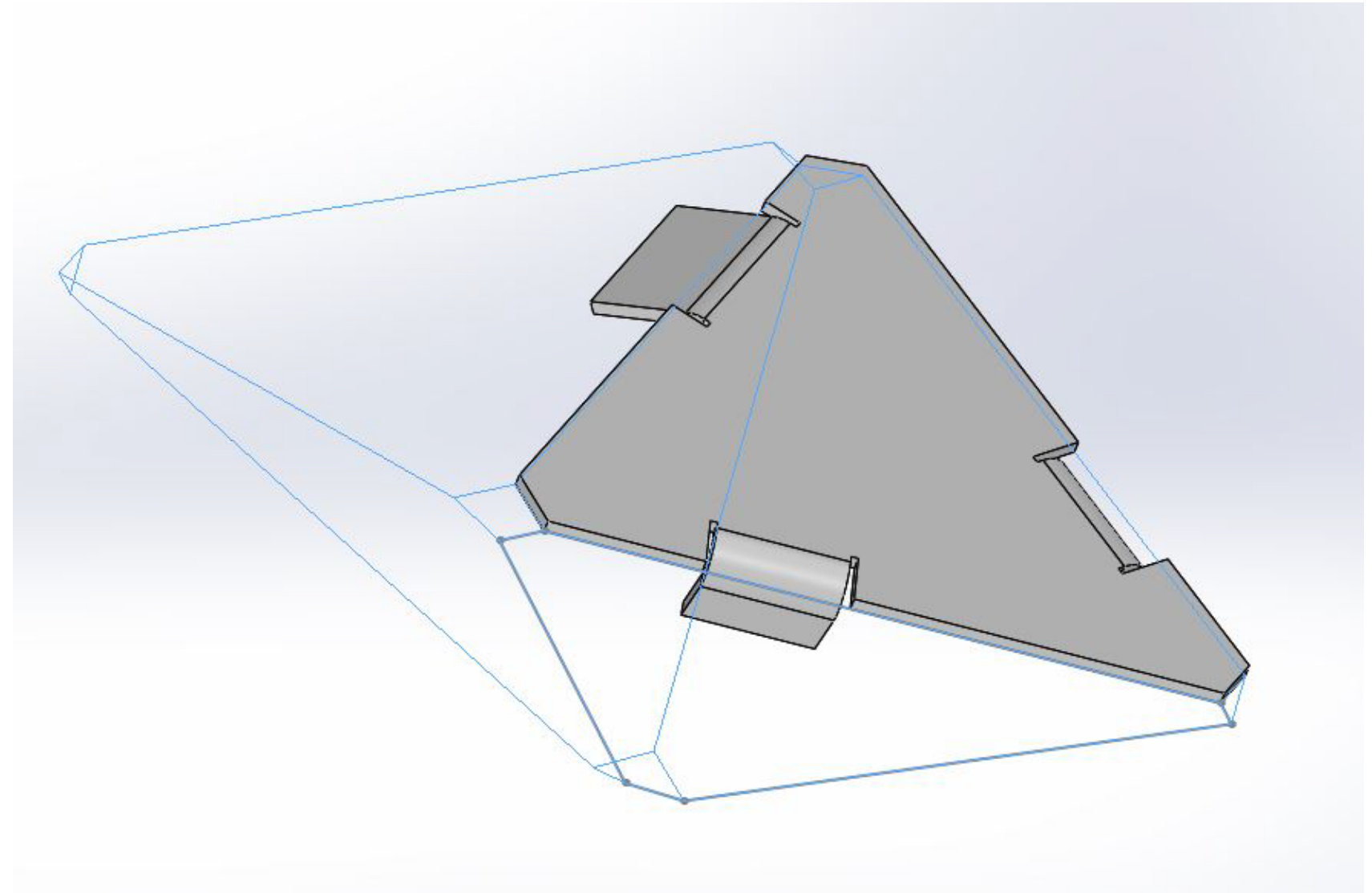

- create sheet metal
- create base flange
- add thickness 1/8"



- add edge frange
- bend

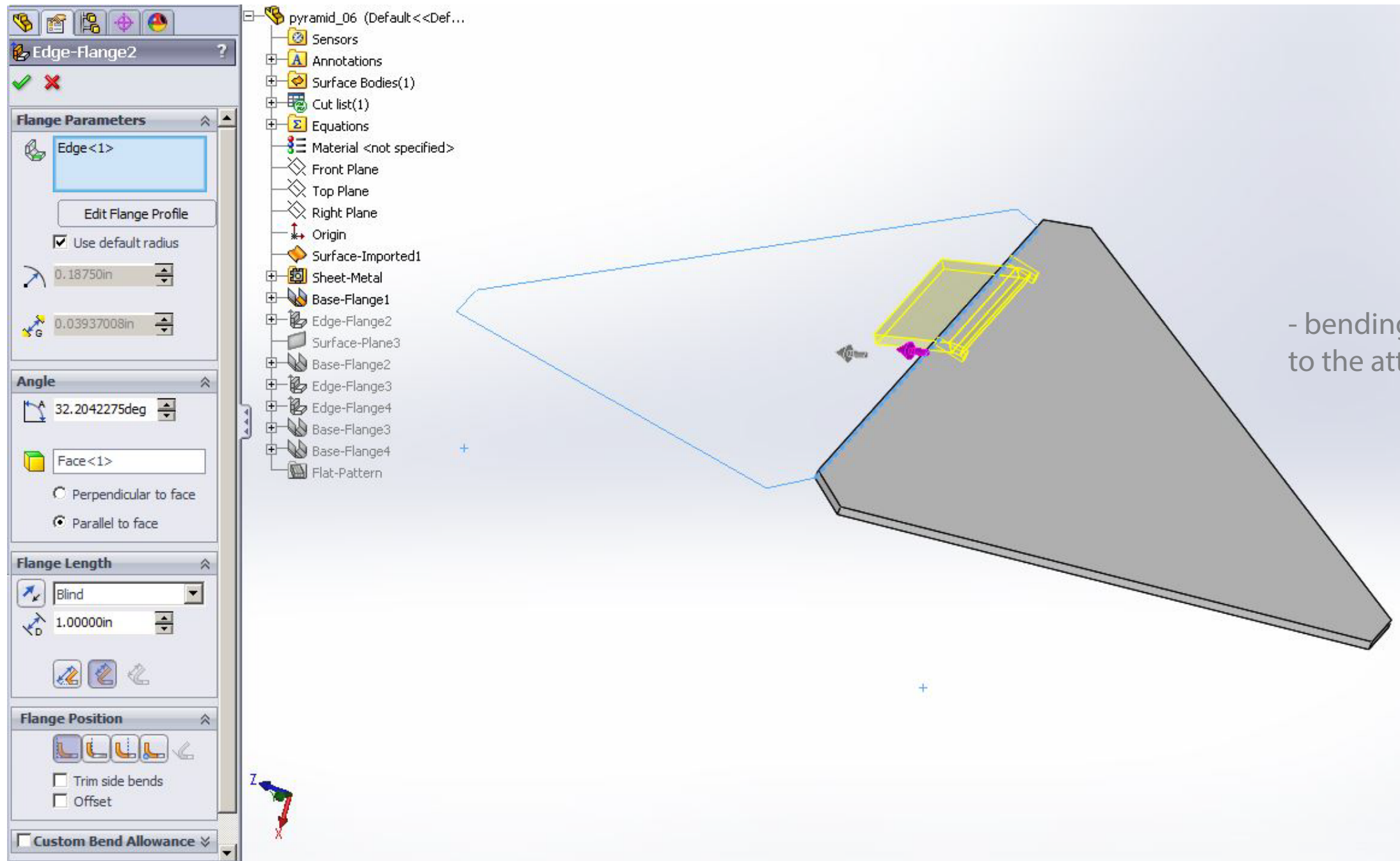

- bending angle is given by using angle **PARALLEL** to the attaching **FACE**

