

MASONRY WALL CONSTRUCTION

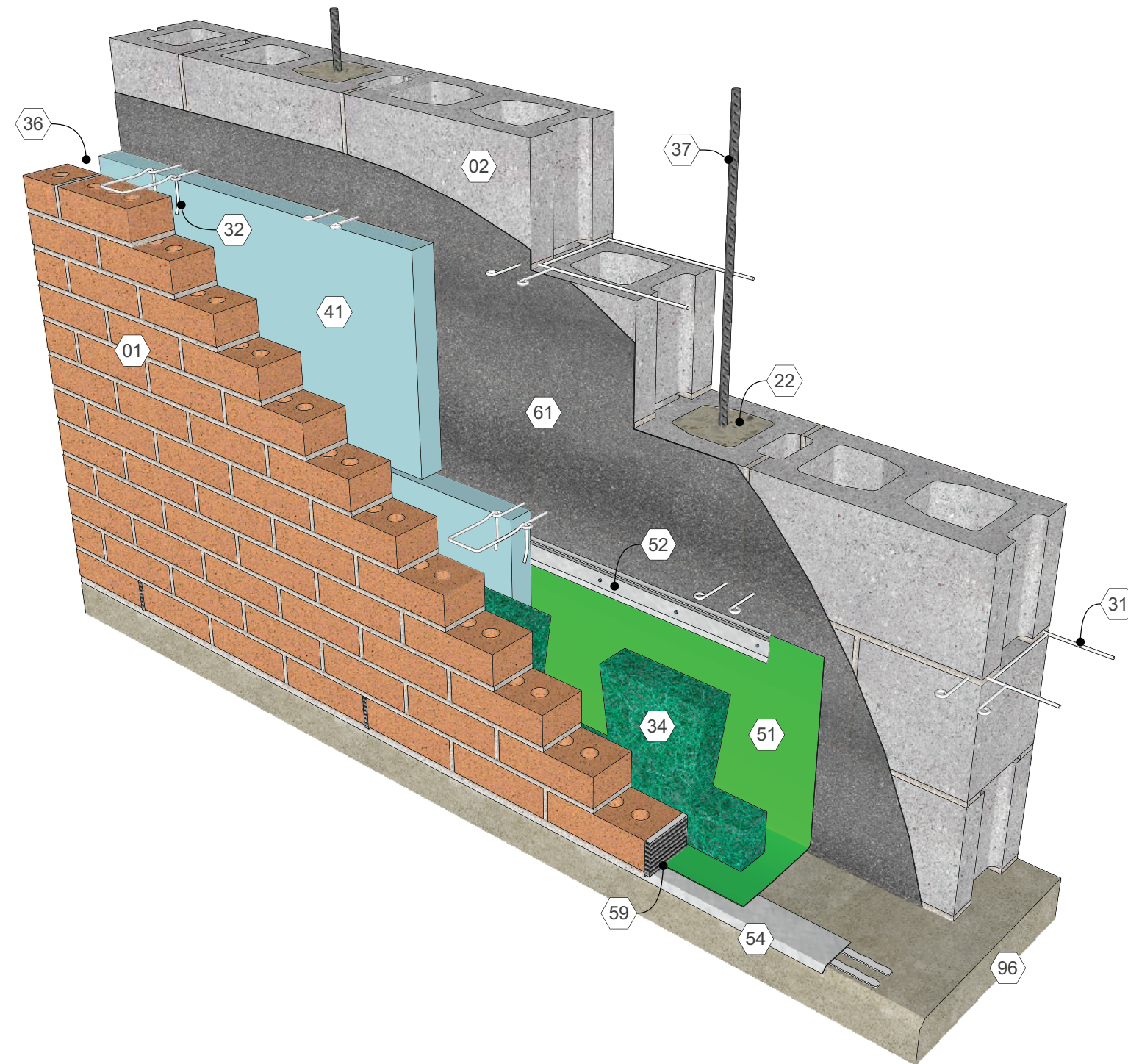

MARCH 24TH, 2020



OLDER BUILDINGS = SOLID MASONRY:

- MASSIVE
- HEAVY
- DURABLE
- VERY LITTLE TENSILE RESISTANCE



NEW BUILDINGS = COMPOSITE MASONRY:

- THINNER
- CHEAPER
- MORE EFFICIENT
- CAN BE REINFORCED TO HANDLE TENSION

TYPES OF MASONRY WALLS



MASONRY LOADBEARING WALLS:

- BRICK, STONE, OR CMU WALLS WHICH CARRY THE STRUCTURAL LOADS OF THE FLOORS AND ROOF TO THE FOUNDATION
- DOUBLE DUTY BY ACTING AS THE STRUCTURE AND THE EXTERIOR WALL AT THE SAME TIME
- TALLEST UNREINFORCED MASONRY BUILDING IN THE WORLD... MONADNOCK BUILDING IN CHICAGO – 16 STORIES W/ 6' THICK WALLS AT BASE



TYPES OF MASONRY WALLS



COMPOSITE MASONRY WALLS:

- BALANCE APPEARANCE AND ECONOMY
- INNER WYTHER OF CMU, OUTER WYTHER OF STONE OR FACE BRICK
- TWO WYTHES BONDED TOGETHER BY JOINT REINFORCING, WALL TIES, OR HEADERS AT THE OUTER WYTHER WHICH ENGAGE THE INNER WYTHER.
- ANY GAPS FILLED WITH MORTAR TO CREATE A SOLID MASS
- BECAUSE THE WALL ACTS AS A SINGLE MASS, THE INNER AND OUTER WYTHER MATERIALS MUST HAVE SIMILAR THERMAL EXPANSION PROPERTIES OR THE WALL WILL START TO CRACK OR BOW

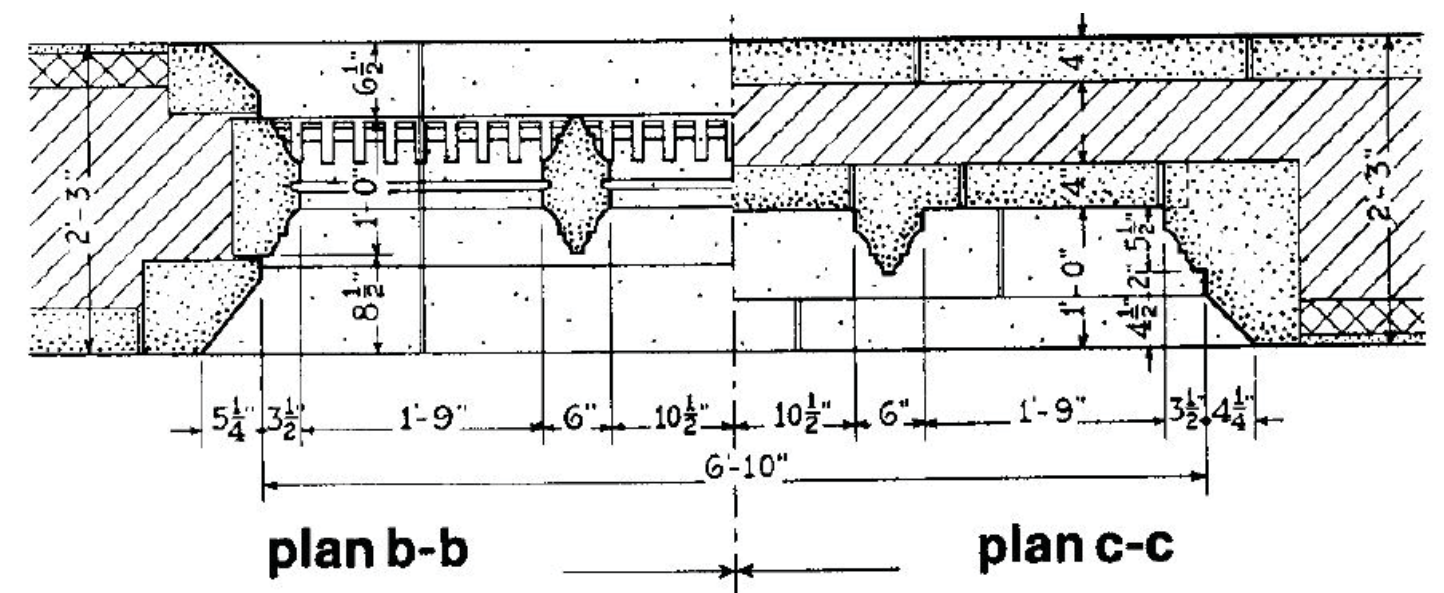

TYPES OF MASONRY WALLS



REINFORCED MASONRY WALLS:

- UNREINFORCED WALLS HAVE REDUCED STRUCTURAL CAPABILITIES, AND CANNOT RESIST LATERAL LOADS (SEISMIC, WIND, EARTH PRESSURE)
- STEEL REINFORCED WALLS CAN BE THINNER, SAVING MATERIAL, LABOR, AND SPACE
- NOW ALL BUT THE SMALLEST MASONRY STRUCTURES ARE REINFORCED

TYPES OF MASONRY WALLS

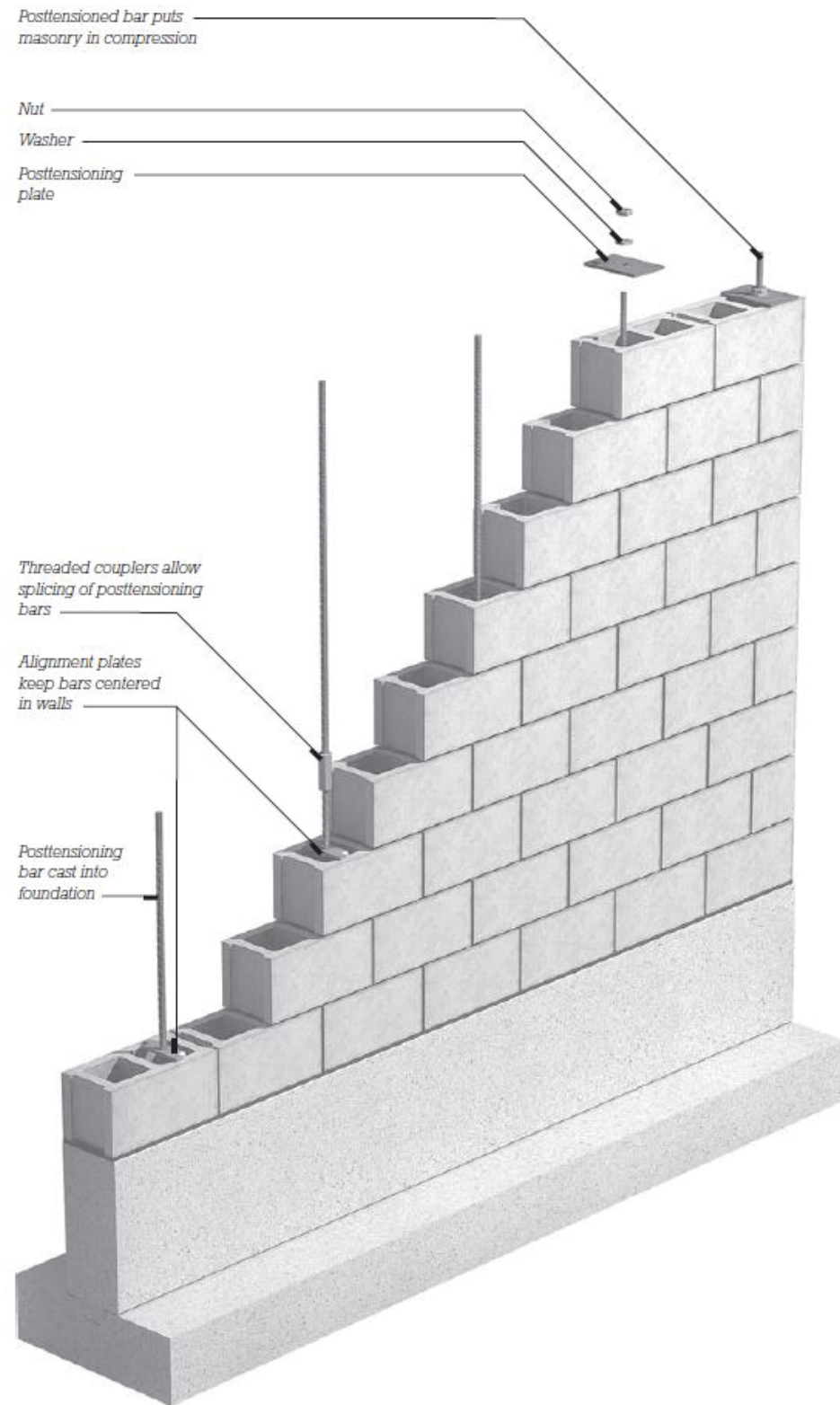

POSTTENSIONED MASONRY WALLS:

- USES HIGH STRENGTH THREADED RODS IN PLACE OF TRADITIONAL REBAR
- RODS ANCHORED INTO FOUNDATION, AND THEN TENSIONED USING STEEL PLATES AND TIGHTENING NUT AT THE TOP OF WALL
- THIS PLACES THE ENTIRE WALL IN COMPRESSION, WHICH STRENGTHENS IT AGAINST TENSILE LOADS (WHICH MASONRY CAN'T HANDLE)
- THIS ALLOWS EVEN THINNER CONSTRUCTION COMPARED TO REINFORCED MASONRY WALLS, USES LESS GROUT FOR THE CORES, AND SAVES LABOR



TYPES OF MASONRY WALLS

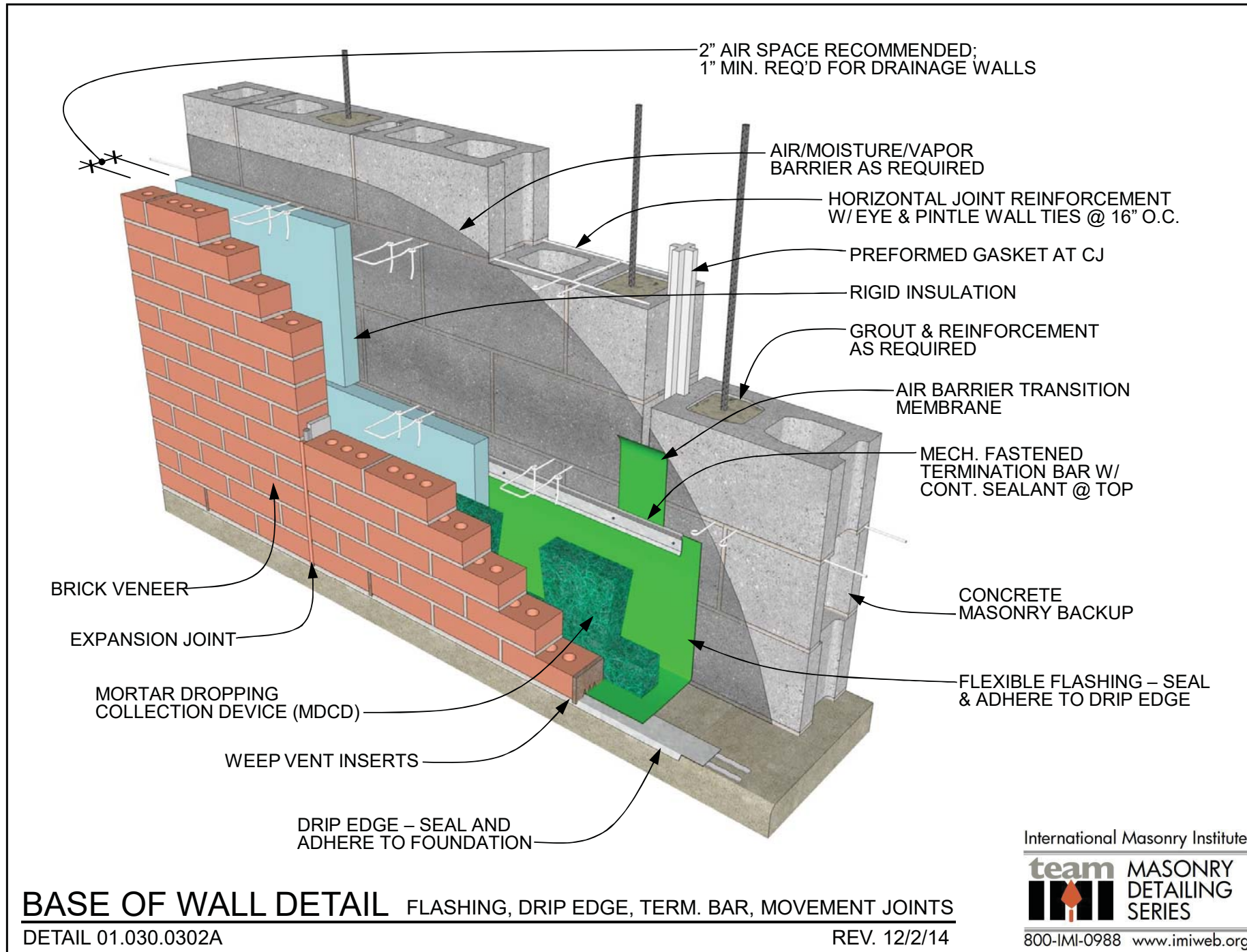

MASONRY CAVITY WALLS:

- MASONRY WALLS ARE POROUS AND ALLOW WATER TO GET THROUGH. CAVITY WALLS ADDRESS THIS BY LEAVING A SPACE BETWEEN THE FRONT AND BACK LAYERS WHICH ALLOWS THE WALL TO SHED WATER BEFORE IT PENETRATES INTO THE BUILDING
- FLASHING AND WEEP HOLES AT THE BASE OF THE WALL SHED WATER BACK OUT
- AIR AND WATER BARRIERS (DAMP-PROOFING) APPLIED TO CAVITY FACE OF INNER WYTHE FOR ADDITIONAL PROTECTION AGAINST MOISTURE
- RIGID FOAM INSULATION CAN BE ADDED TO INCREASE THERMAL BARRIER
- AT LEAST 2" CAVITY RECOMMENDED TO KEEP CLEAR OF MORTAR, CAN BE REDUCED TO 1" MINIMUM
- WEEPS SHOULD BE 24" OC MAX IN BRICK, 32" OC MAX IN CMU
- CAVITY MUST BE KEPT CLEAR TO ALLOW WATER TO PASS THROUGH AND TO AVOID CLOGGING THE WEEPS
- MORTAR NETS AT BASE OF CAVITY HELP ALLEVIATE THIS, THOUGH THEY ARE NOT A SUBSTITUTE FOR CAREFUL CONSTRUCTION

TYPES OF MASONRY WALLS

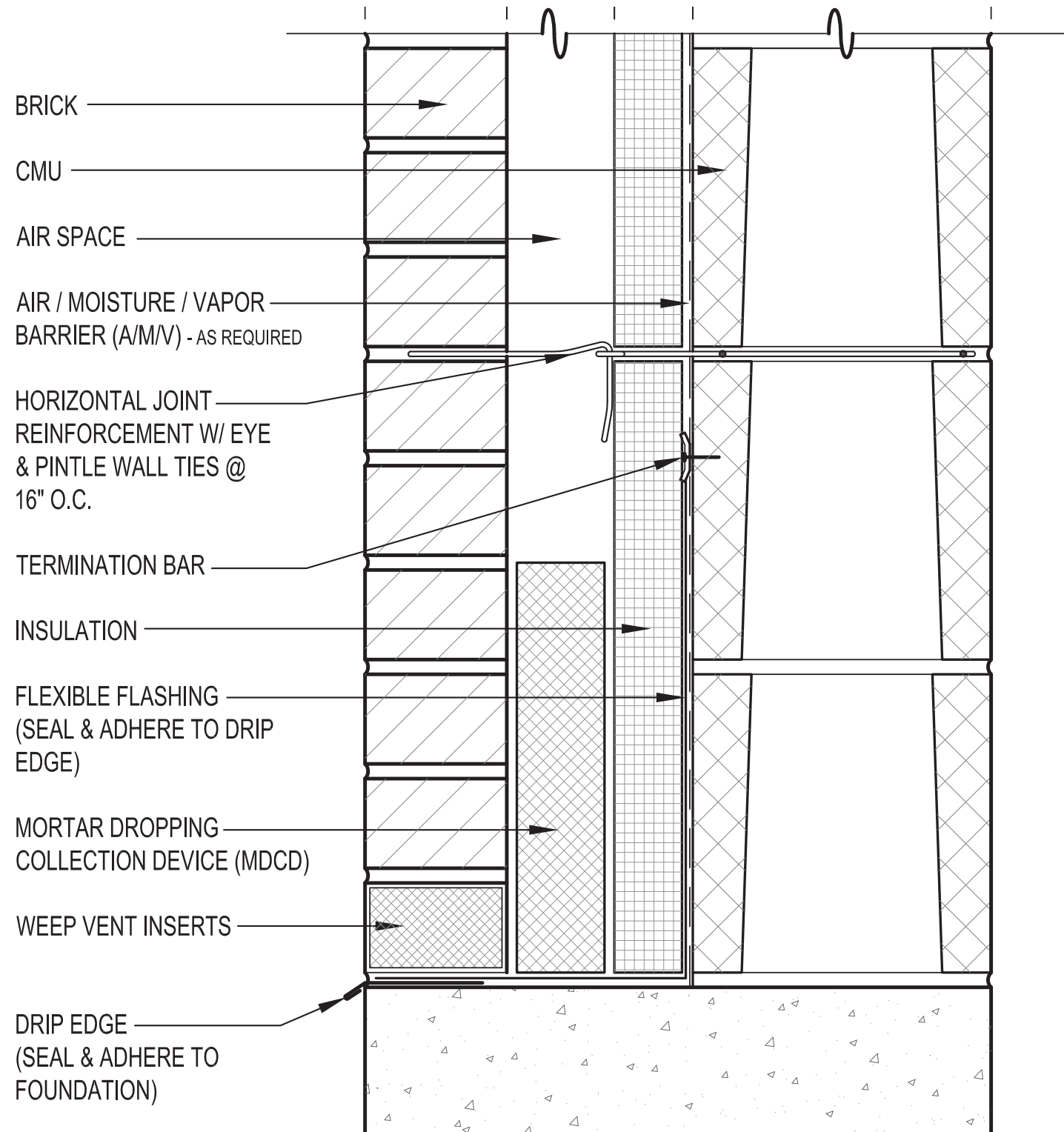

MASONRY CAVITY WALLS:

- IN A LOADBEARING WALL, THE BACK WYTHE CARRIES THE LOAD WHILE THE FRONT WYTHE IS ONLY A VENEER
- IN A NON-LOADBEARING WALL, NEITHER WYTHE CARRIES A STRUCTURAL LOAD, THOUGH THE BACK WYTHE STILL SUPPORTS THE VENEER THROUGH THE METAL TIES WHICH ANCHORS THE VENEER IN PLACE
- CAVITY WALLS DO NOT ALWAYS USE CMU AS THE BACKING. LIGHT STEEL OR WOOD STUD FRAMING IS ALSO COMMON

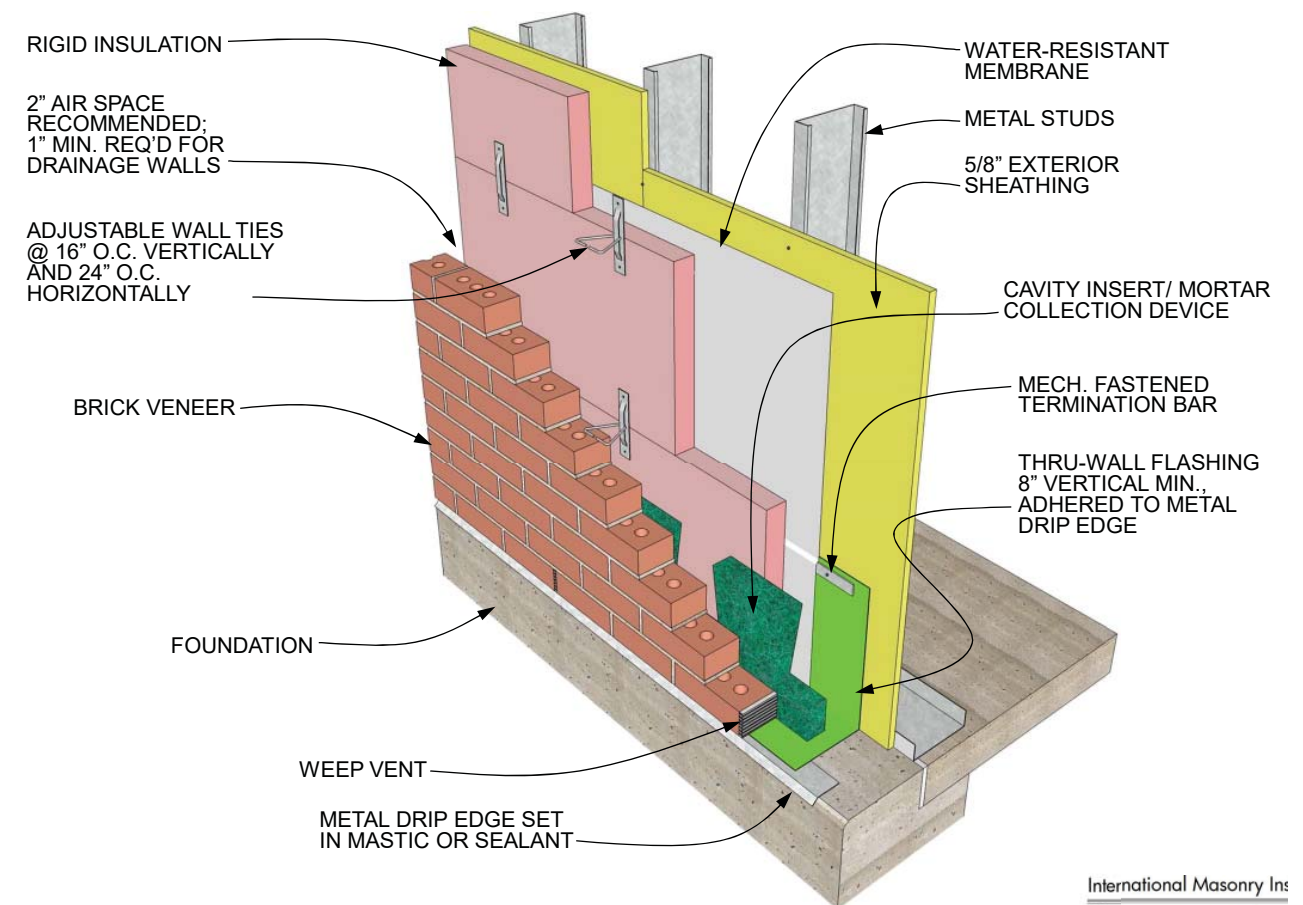

CAVITY WALL DETAILS - MASONRY TIES + JOINT REINFORCING

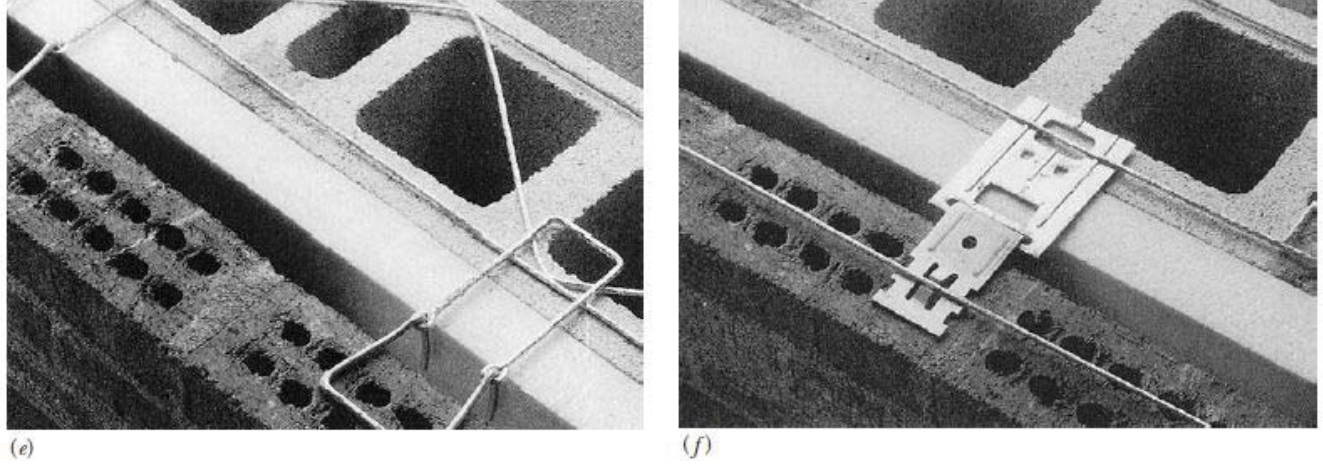
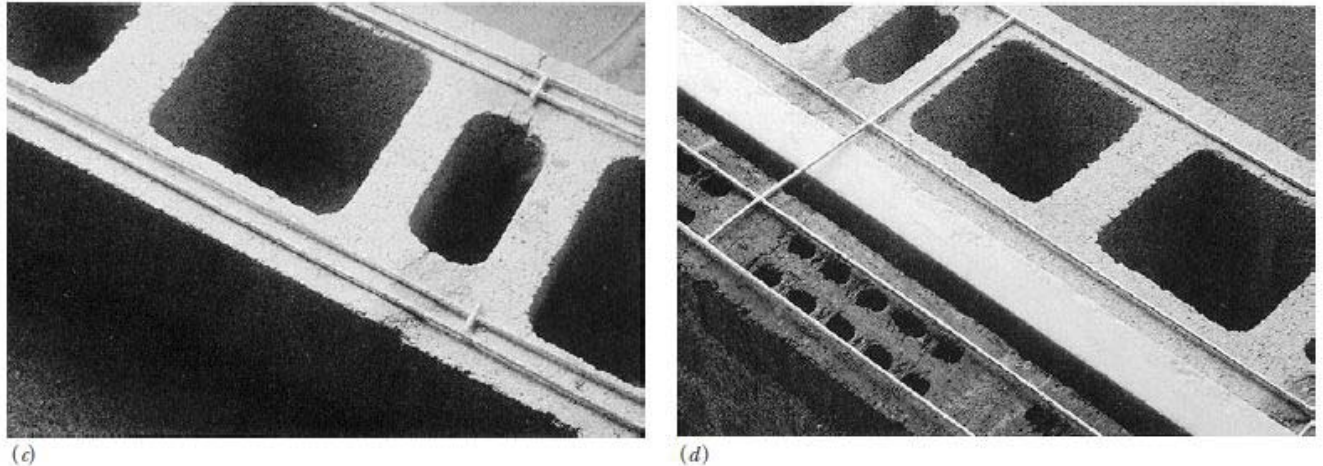
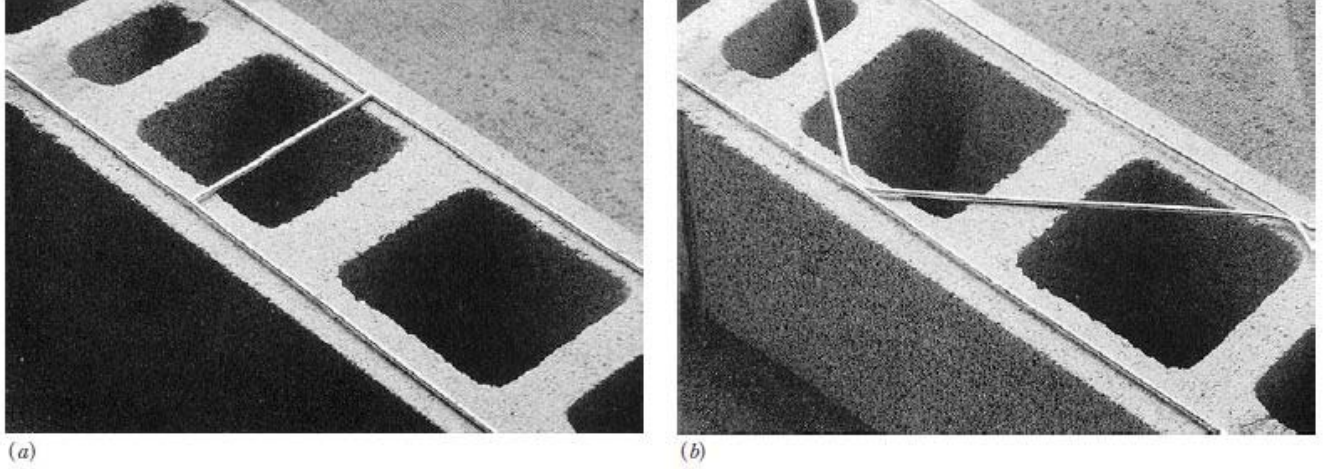
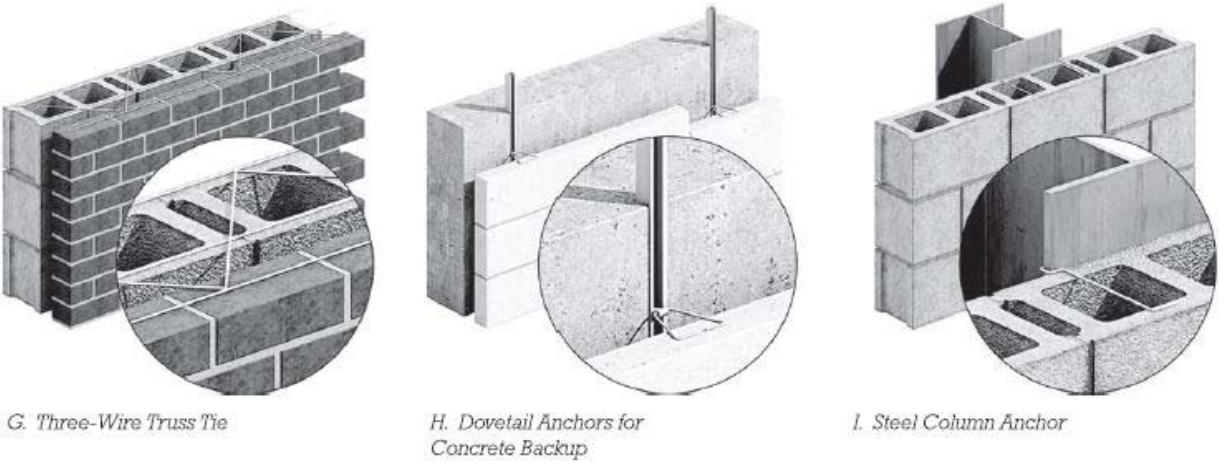
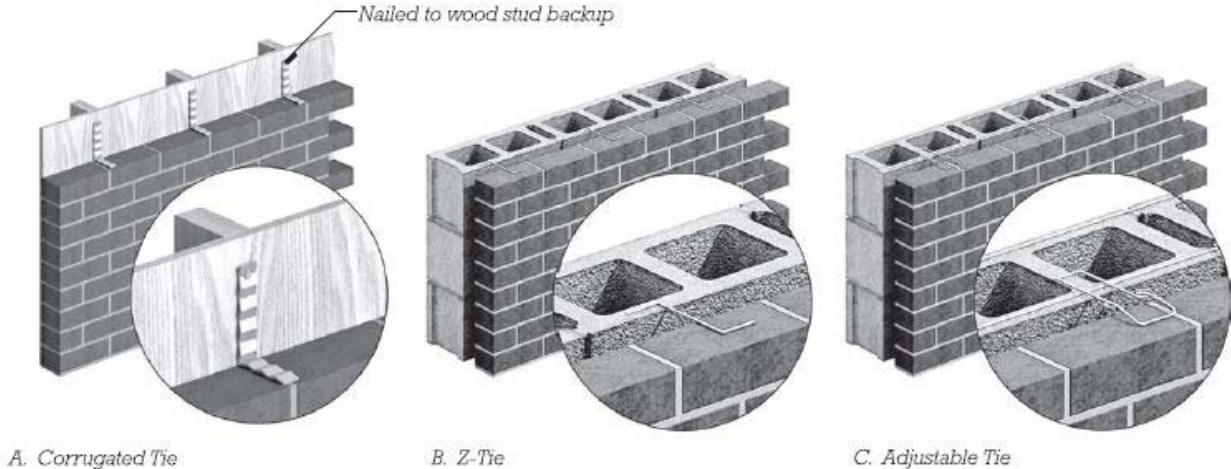

CAVITY WALL DETAILS - FLASHING + WEEPS

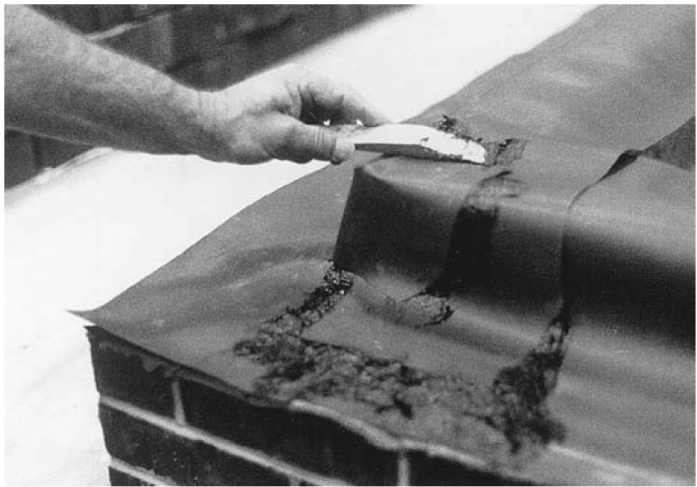

(a)

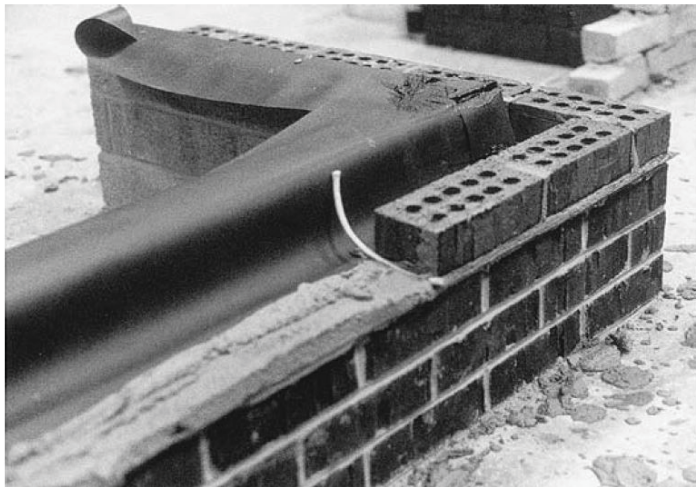

(b)



CAVITY WALL DETAILS - MORTAR NETS

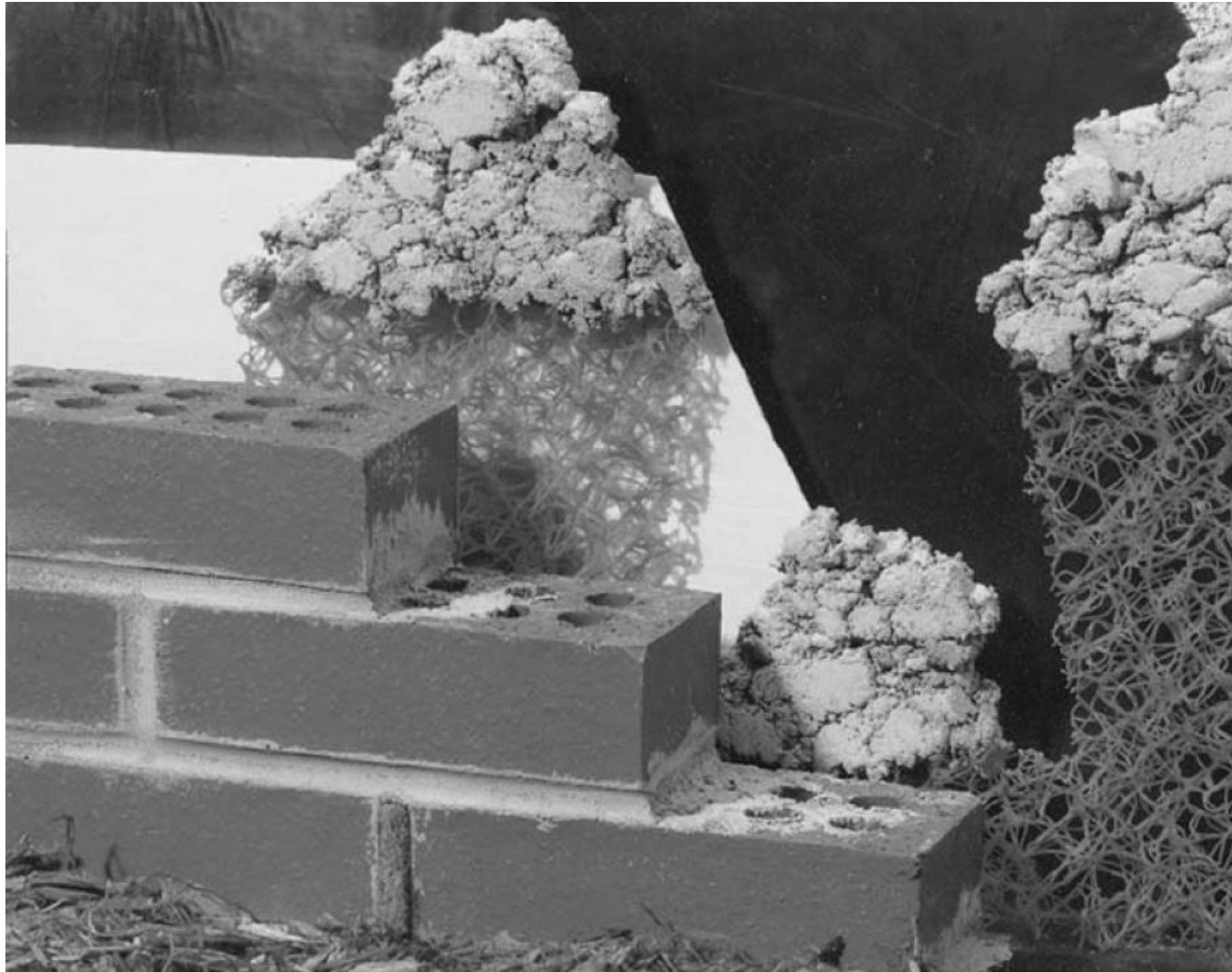

MORTAR NETS AT BASE OF CAVITY HELP KEEP THE WEEP HOLES CLEAR OF MORTAR, THOUGH THEY ARE NOT A SUBSTITUTE FOR CAREFUL CONSTRUCTION . IF MASON IS NOT CAREFUL, MORTAR CAN STILL BUILD UP AT THE BASE AND LIMIT THE FLOW OF WATER.

CAVITY WALL DETAILS - ROOF + SLAB EDGE + BASE

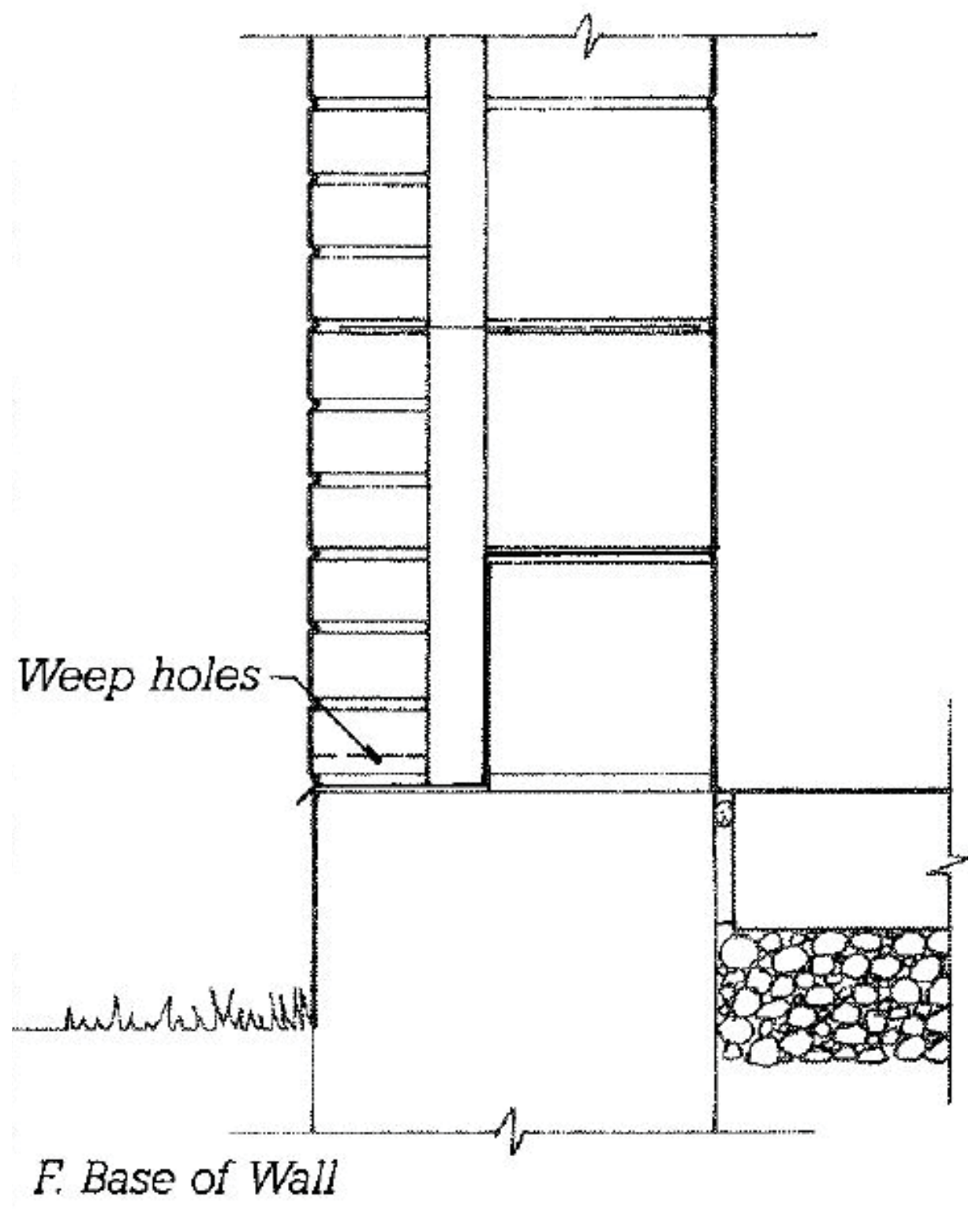
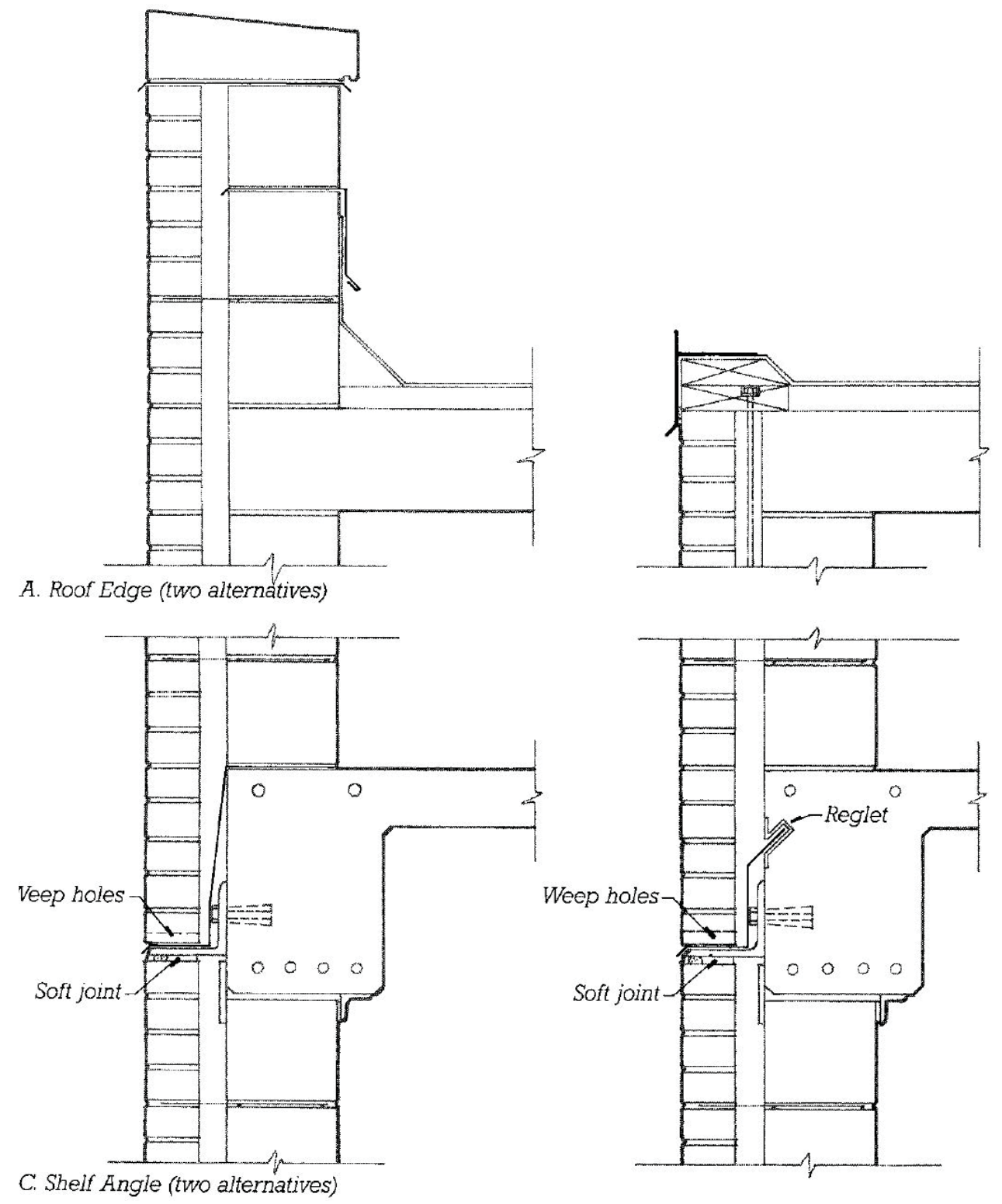
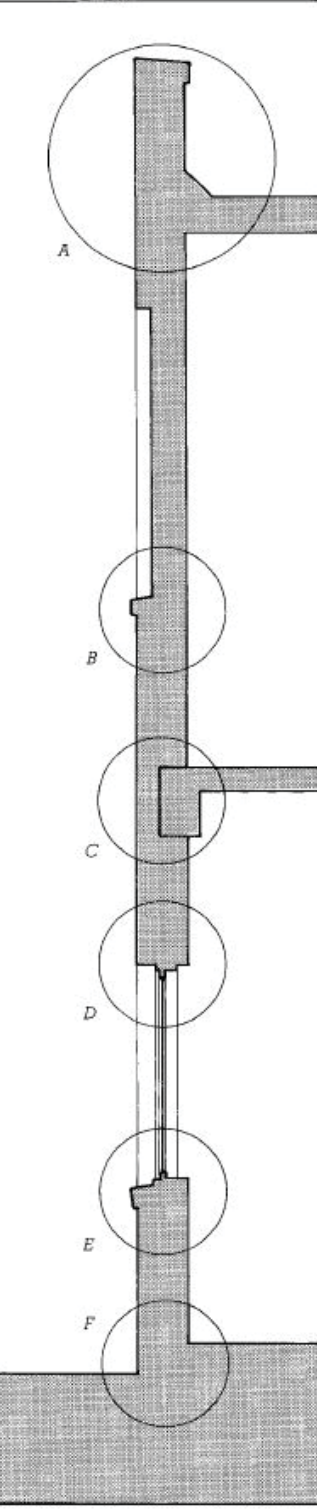

SPANNING SYSTEMS FOR MASONRY BEARING WALLS

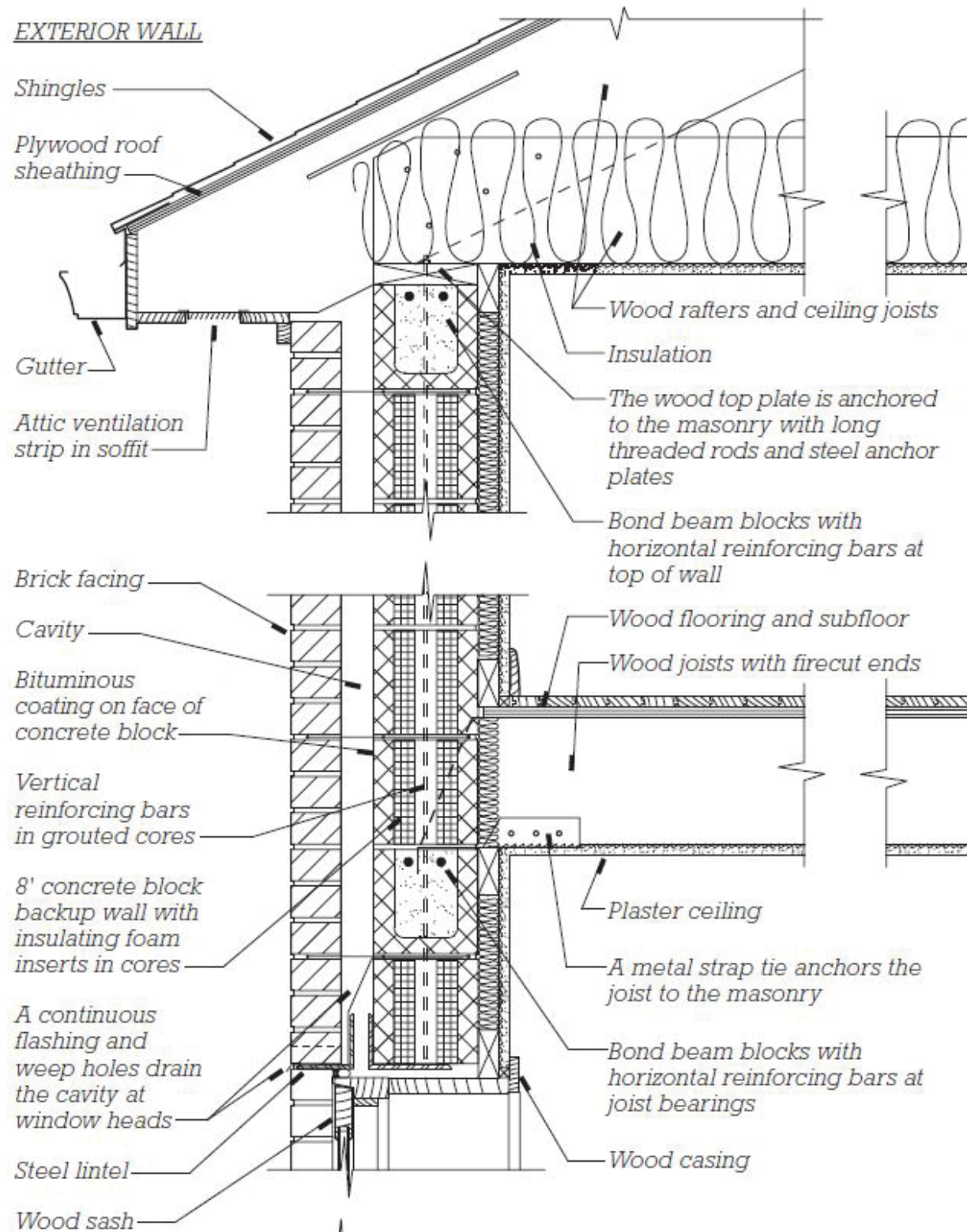

ORDINARY JOISTED CONSTRUCTION:

- FLOORS AND ROOFS FRAMED WITH WOOD JOISTS AND RAFTERS, SUPPORTED BY THE MASONRY WALLS, INTERIOR WALLS FRAMED WITH LUMBER
- VERY COMMON IN THE 1800S
- FIRE CUT ENDS KEEP WALLS FROM GETTING DAMAGED IF FLOOR JOISTS BURN OUT

HEAVY TIMBER / MILL CONSTRUCTION:

- SIMILAR TO ORDINARY CONSTRUCTION, BUT REPLACED JOISTS, RAFTERS, AND SHEATHING/SUBFLOORING WITH HEAVY TIMBER BEAMS AND THICK TIMBER DECKING
- MORE FIRE RESISTANT THAN ORDINARY CONSTRUCTION, THUS LARGER FLOOR AREAS PERMITTED

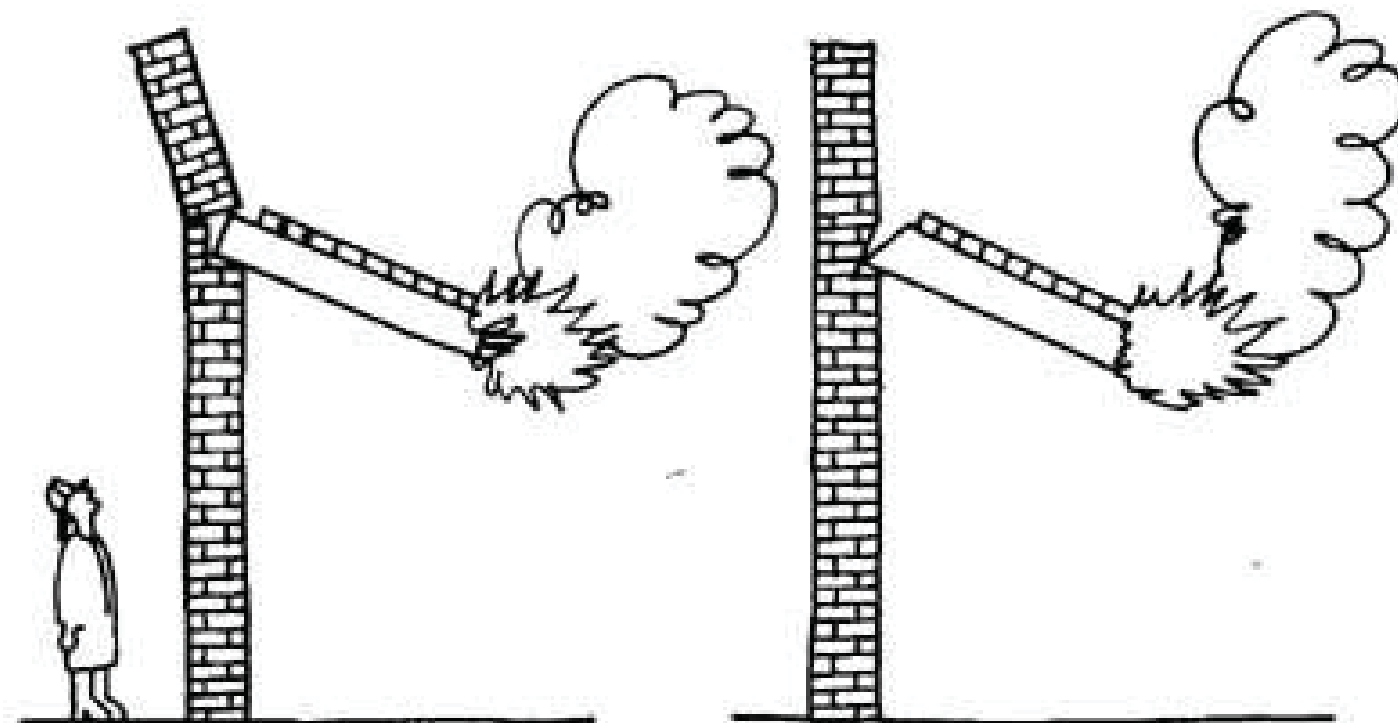

Square-cut beam

Firecut beam

SPANNING SYSTEMS FOR MASONRY BEARING WALLS

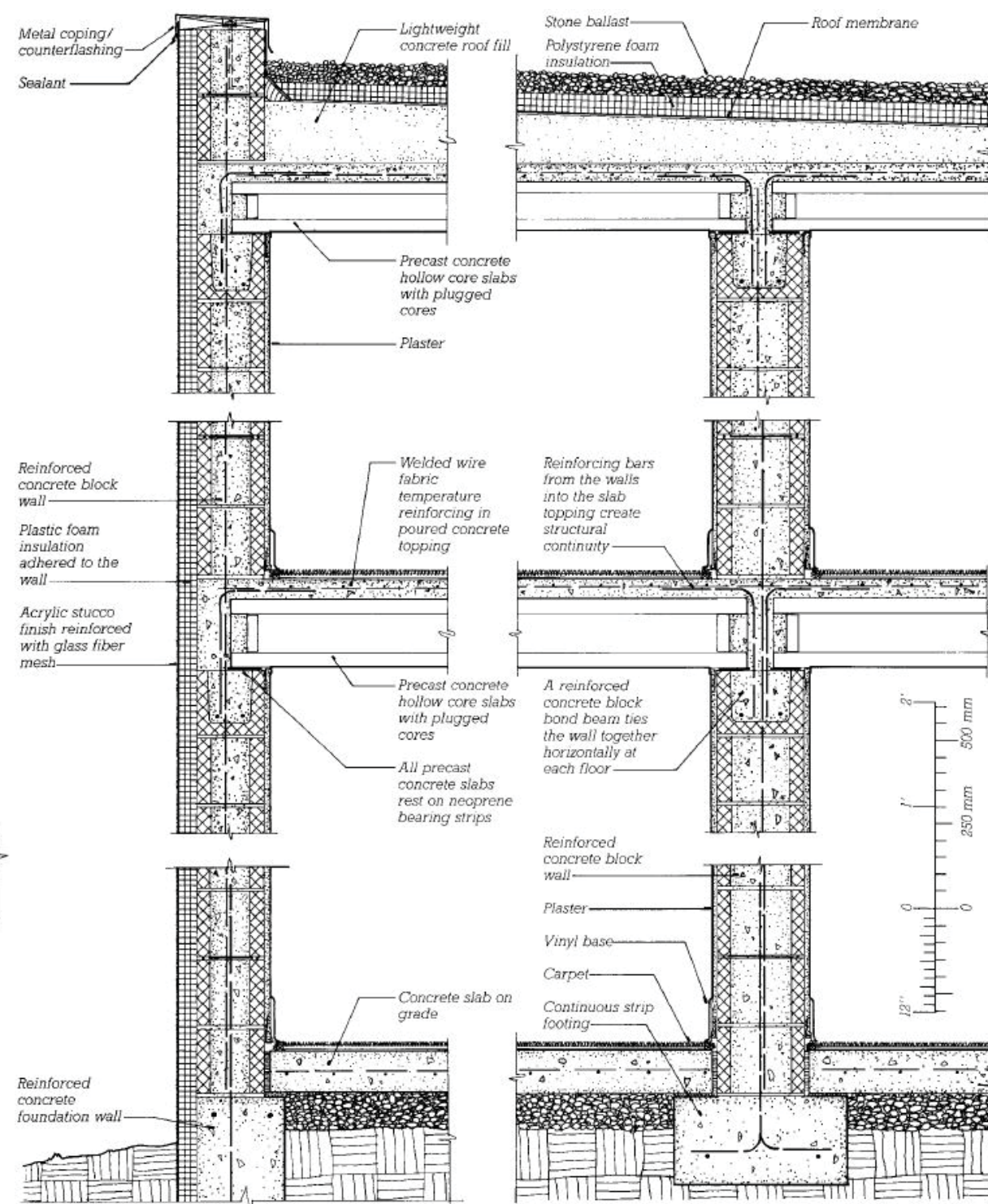
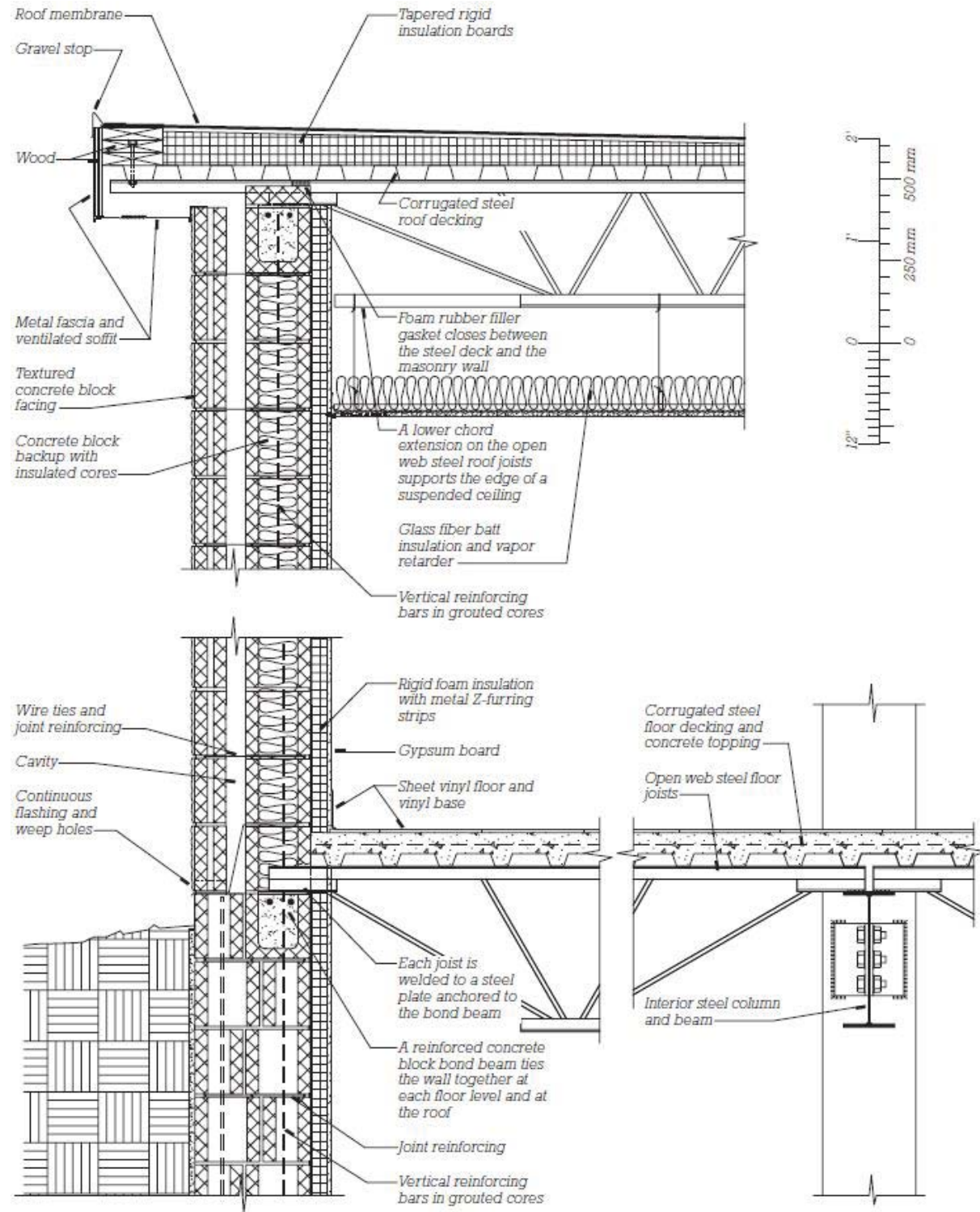

STEEL AND CONCRETE DECKS:

- USES STEEL OR CONCRETE SPANNING SYSTEMS WHICH ARE SUPPORTED BY THE MASONRY BEARING WALL

DETAILING MASONRY WALLS



FLASHINGS AND DRAINAGE:

- TWO TYPES OF FLASHING
- EXTERNAL - KEEPS WATER OUT, INSTALLED AT INTERSECTIONS, USUALLY BASE FLASHING AND COUNTERFLASHING / CAP FLASHING
- INTERNAL (CONCEALED, THROUGH-WALL) - CATCH WATER THAT'S GOTTEN IN AND FORCES IT BACK OUT THROUGH WEEPS . INSTALLED AS THE WALL IS BEING BUILT. NEEDED AT EVERY LOCATION WHERE THE CAVITY IS INTERRUPTED. FLASHING THAT CROSSES THE CAVITY SHOULD BE TURNED UP AND TIED INTO THE BACK WYTHE OR REGLET

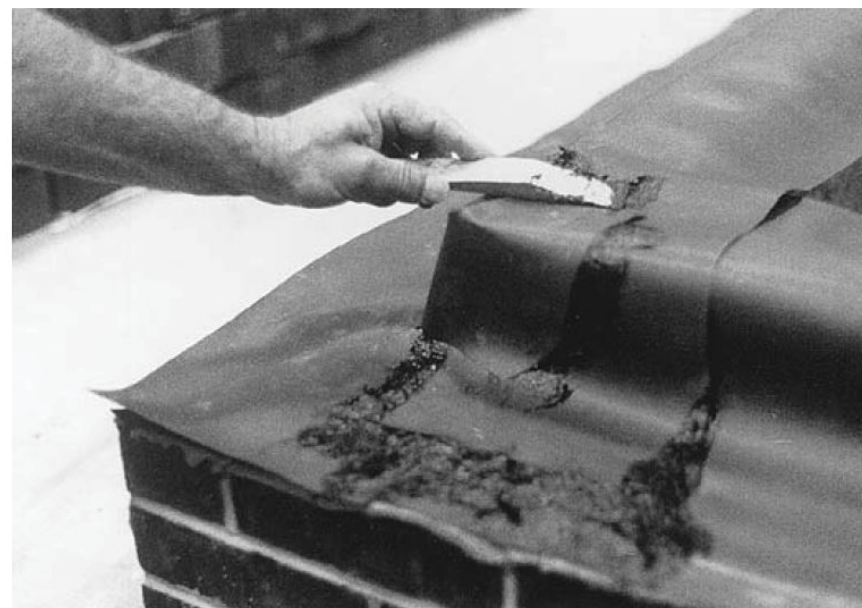

(a)

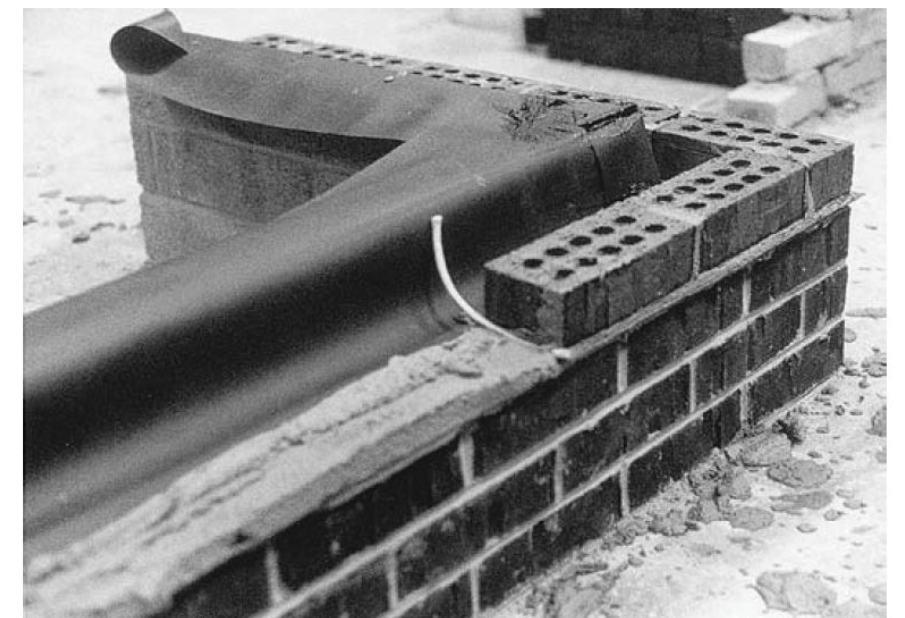

(b)

DETAILING MASONRY WALLS



FLASHINGS AND DRAINAGE:

- FLASHING NEEDS TO EXTEND OUTSIDE OF THE WALL AND DOWN AT A 45 DEGREE ANGLE TO DRIP
- CAN BE MADE OF SHEET METAL, ASPHALT MEMBRANES, PLASTIC, RUBBER, OR COMPOSITES
- SELF-ADHERED FLASHINGS HAVE ADHESIVES ON ONE SIDE AND ARE FLEXIBLE AND EASY TO INSTALL – USUALLY INSTALLED WITH SHEET METAL ON TOP
- PLASTICS AND RUBBER BREAK DOWN TO EASILY AND SHOULD NOT BE USED IN MASONRY WALLS
- FLASHING IS ALMOST IMPOSSIBLE TO REMOVE ONCE THEY'RE INSTALLED, SO IT'S BEST TO USE DURABLE MATERIALS (DON'T CHEAP OUT!!!)
- CORNERS AND UNUSUAL SHAPES ARE TRICKY
- ALL LAPS NEED TO BE SEALED
- HEAD AND SILL FLASHINGS SHOULD TERMINATE IN END DAMS

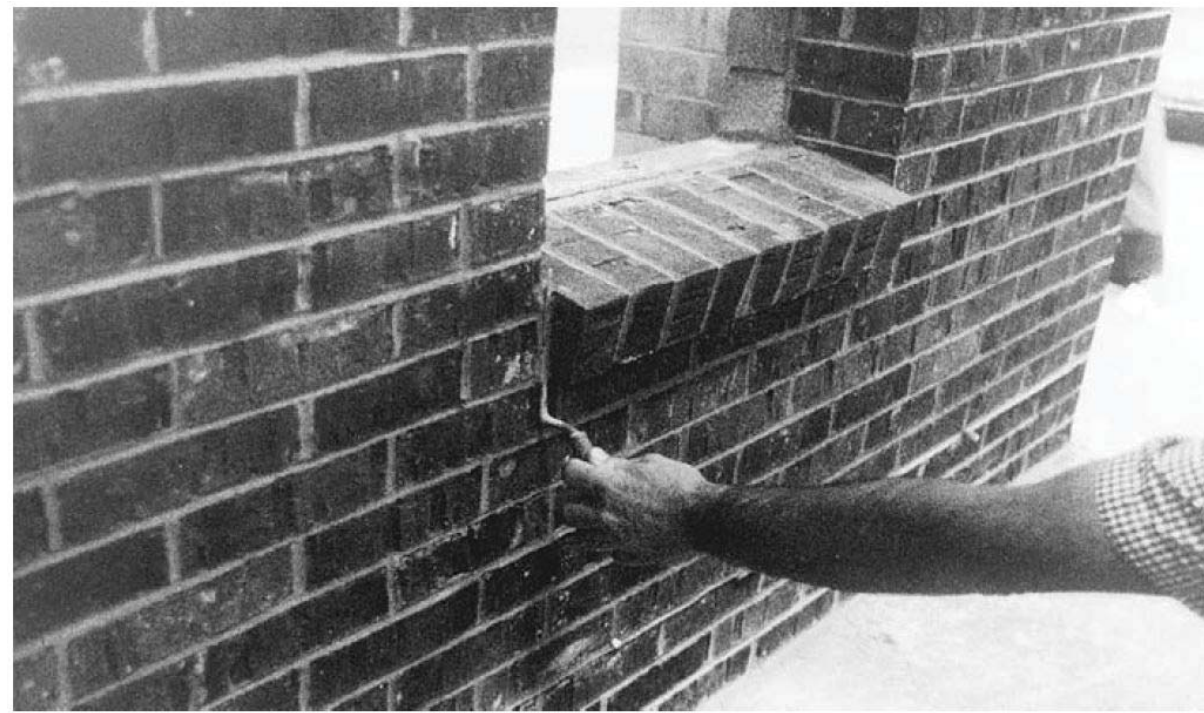
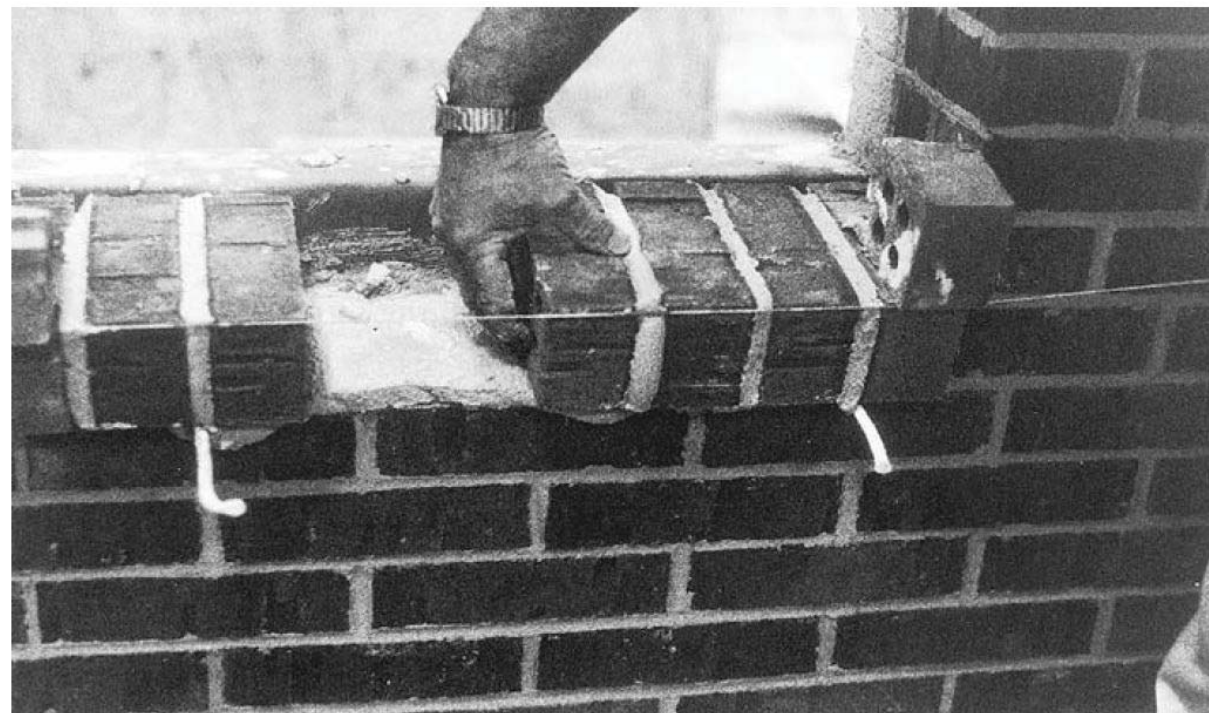

THERMAL INSULATION OF MASONRY WALLS

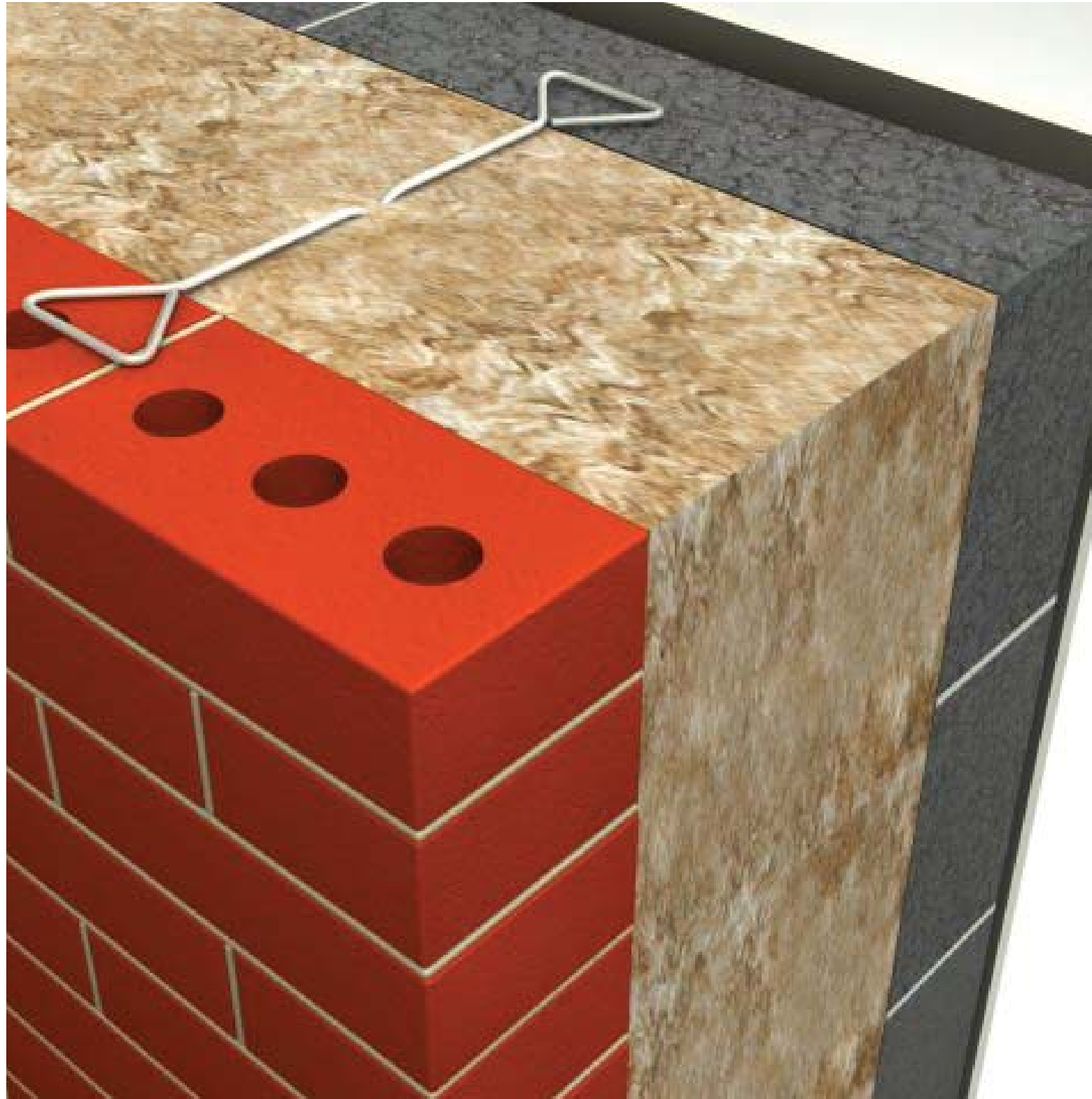

- SOLID MASONRY CONDUCT HEAT = BAD INSULATOR
- IN HOT, DRY CLIMATES, SOLID MASONRY CAN HOLD HEAT AND RELEASE IT AT NIGHT WHEN THE TEMPERATURES DROP
- IN OTHER CLIMATES, WE MUST INCREASE THE THERMAL RESISTANCE OF MASONRY WALLS

3 TYPICAL WAYS OF DOING IT:

- INSULATION ON EXTERIOR
- INSULATION WITHIN WALL
- INSULATION AT INTERIOR

THERMAL INSULATION OF MASONRY WALLS

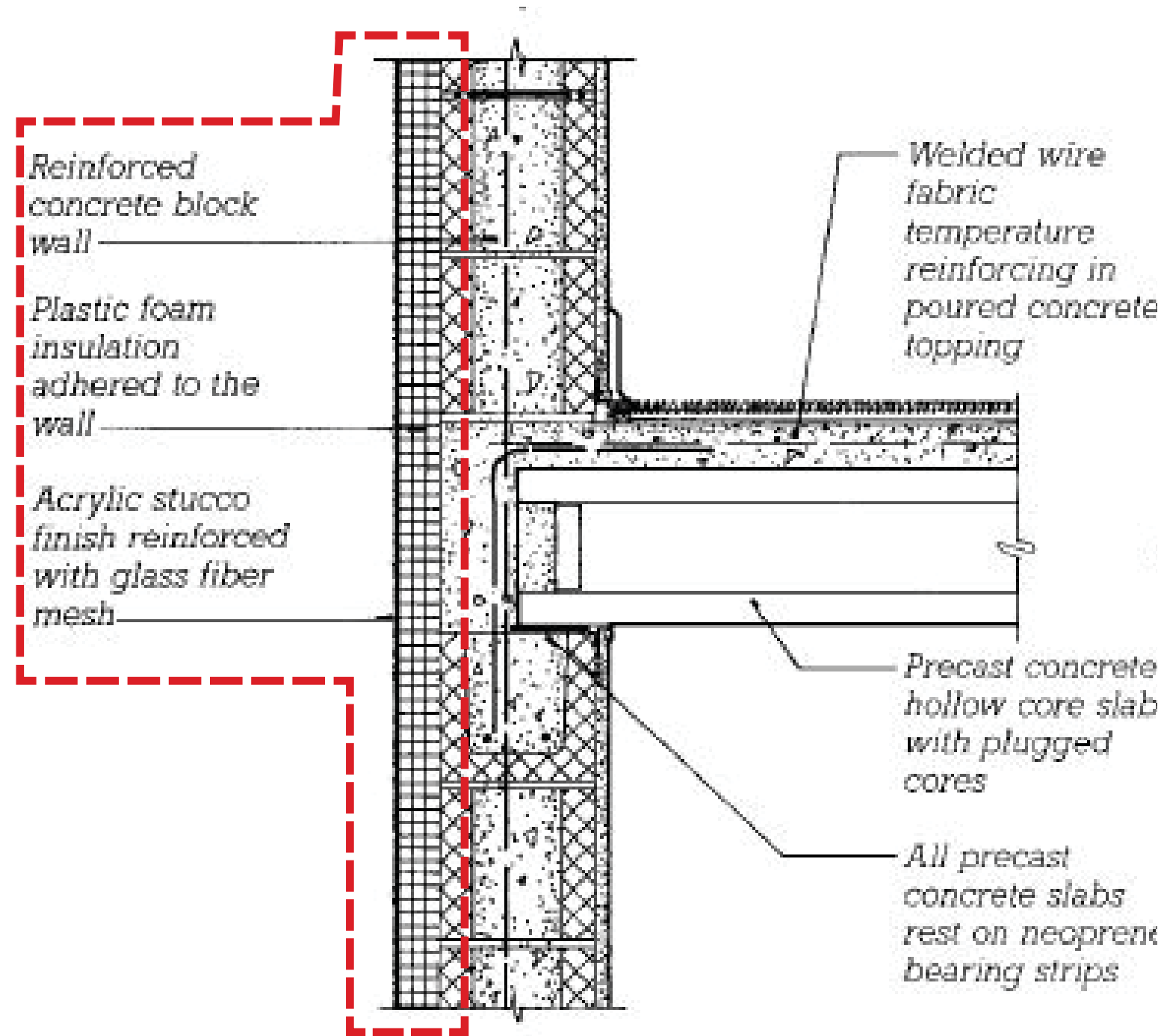

INSULATION ON EXTERIOR:

- USUALLY EIFS – CONTINUOUS INSULATION WITH STUCCO LOOKING FINISH
- MASONRY DOES NOT HAVE TO LOOK GOOD, AND IS PROTECTED FROM LARGE TEMPERATURE CHANGES
- EIFS IS NOT A VERY RESILIENT MATERIAL, AND IS SUSCEPTIBLE TO WATER LEAKAGE



THERMAL INSULATION OF MASONRY WALLS

INSULATION WITHIN WALL:

- RIGID INSULATION IN CAVITY
- CORES OF CMU CAN BE FILLED - BEST TO COMBINE WITH RIGID TO CREATE AN UNBROKEN THERMAL BARRIER

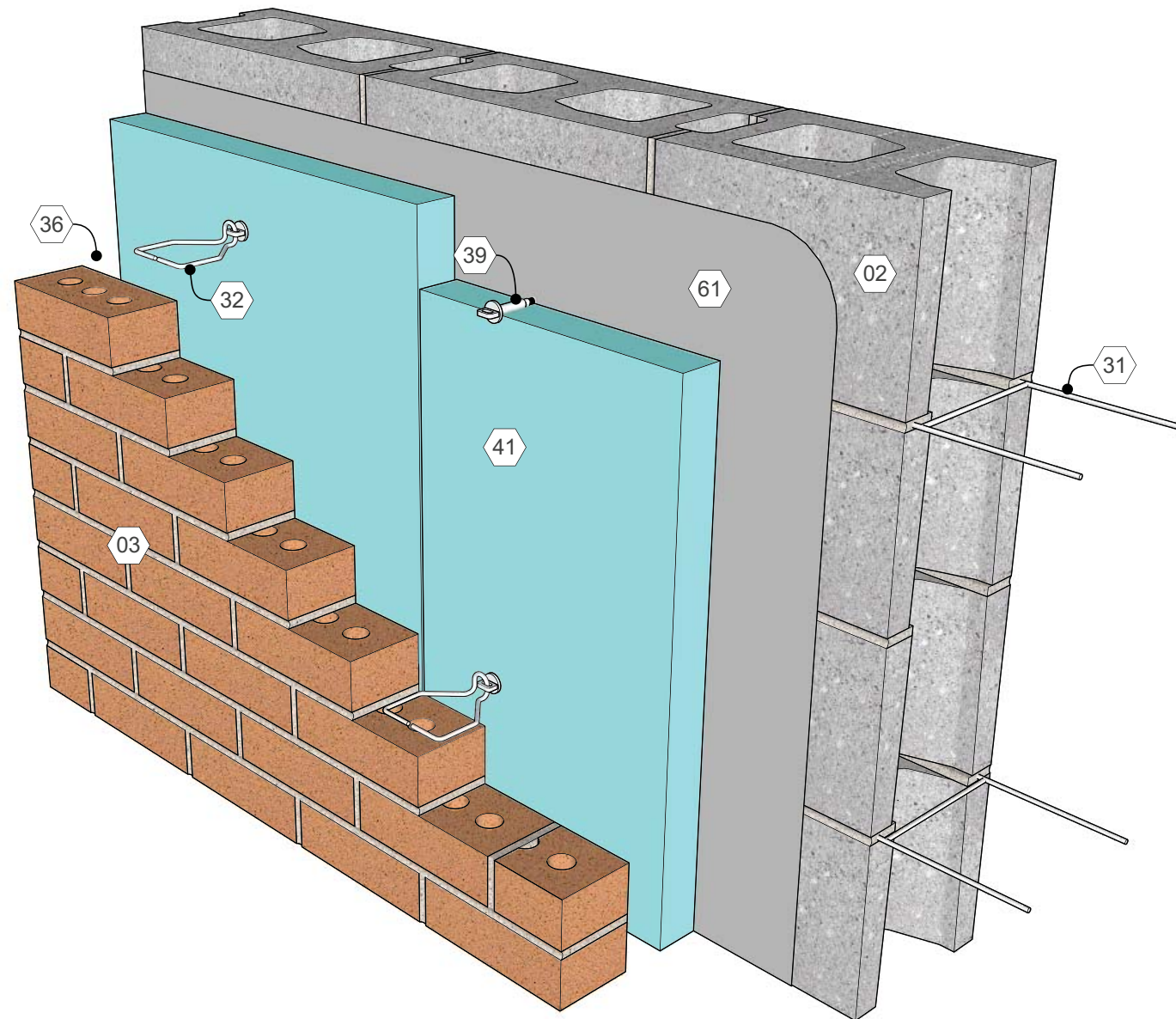

THERMAL INSULATION OF MASONRY WALLS

INSULATION AT INTERIOR:

- WOOD OR METAL FURRING WITH INSULATION
- REQUIRES INTERIOR FINISH MATERIAL OVER FURRING
- ADVANTAGE OF HAVING PLUMBING AND ELECTRICAL AND ELECTRICAL RUN IN THE STUD WALL



SPECIAL PROBLEMS OF MASONRY CONSTRUCTION

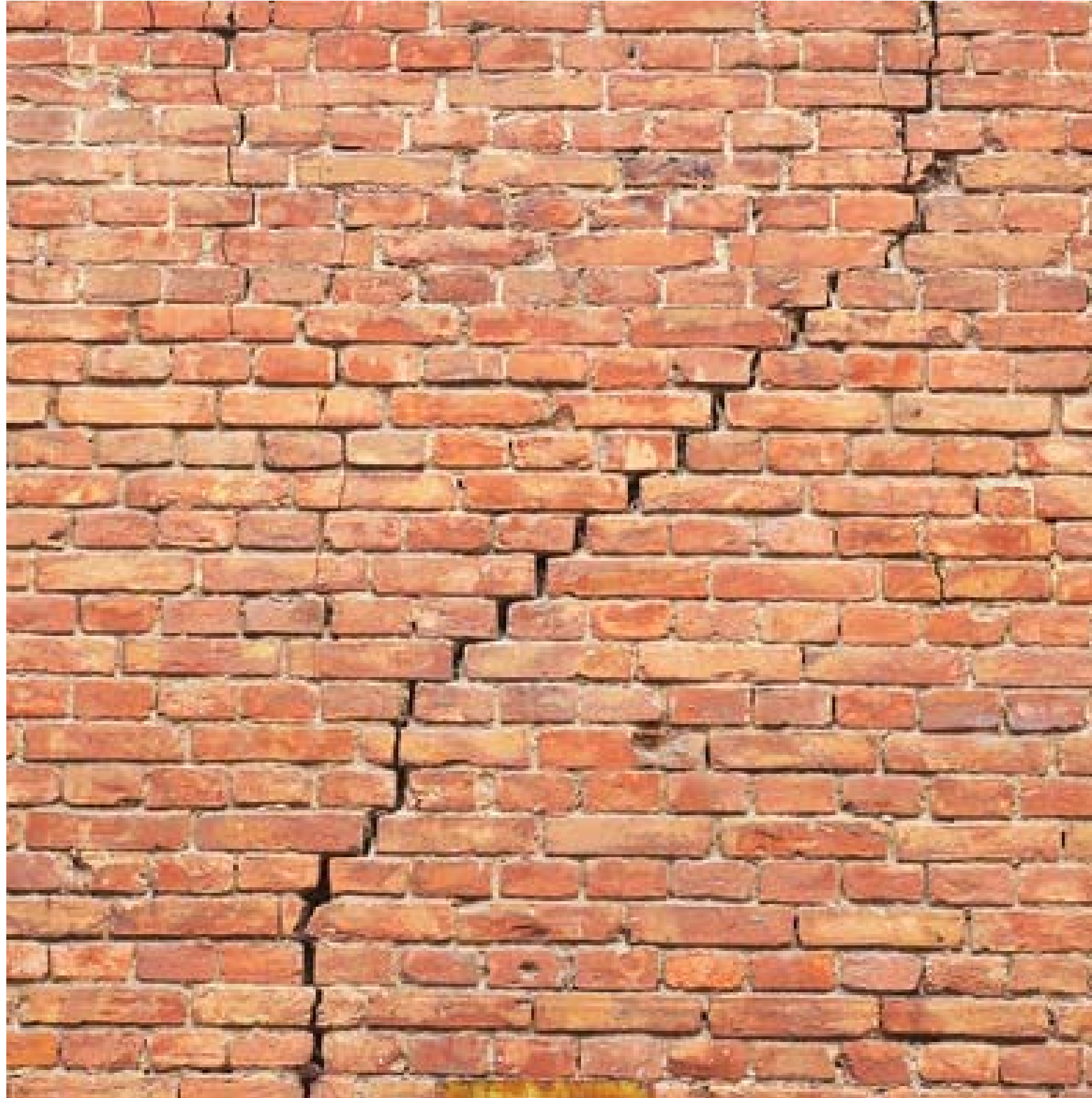

EXPANSION AND CONTRACTION:

- MASONRY WALLS (ALONG WITH EVERY OTHER MATERIAL) EXPAND AND CONTRACT BASED ON TEMPERATURE AND MOISTURE
- EXPANSION AND CONTRACTION IS RELATIVELY SMALL IN MASONRY COMPARED TO WOOD AND METAL, BUT MUST STILL BE ACCOUNTED FOR WITH SURFACE JOINTS

3 TYPES OF SURFACE JOINTS

- EXPANSION JOINTS - SLOTS THAT CAN CLOSE SLIGHTLY TO ACCOMMODATE EXPANSION
- CONTROL JOINTS - INTENTIONALLY CUT CRACKS IN THE MATERIAL THAT CAN ABSORB SHRINKAGE
- ABUTMENT (ISOLATION) JOINTS - SEPARATE DIFFERENT MATERIALS SO THAT THEY CAN EXPAND AT DIFFERENT RATES

SPECIAL PROBLEMS OF MASONRY CONSTRUCTION

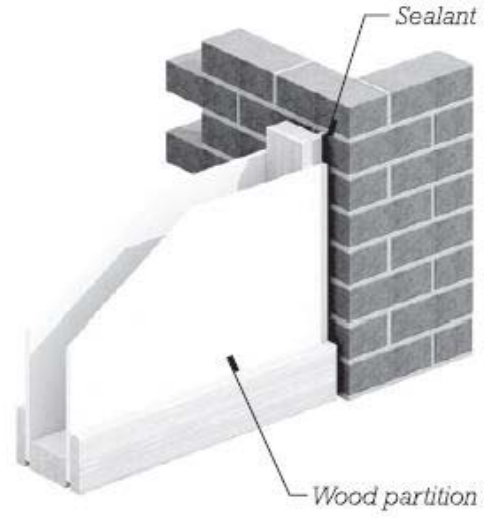
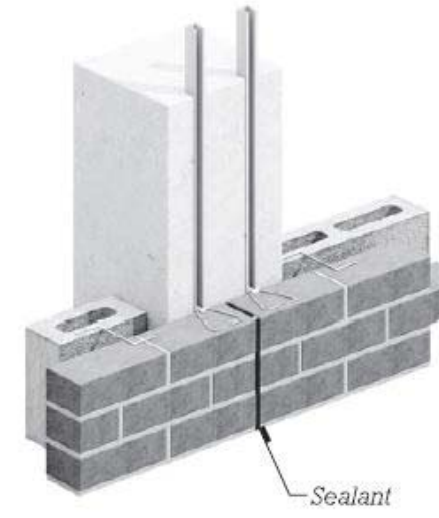
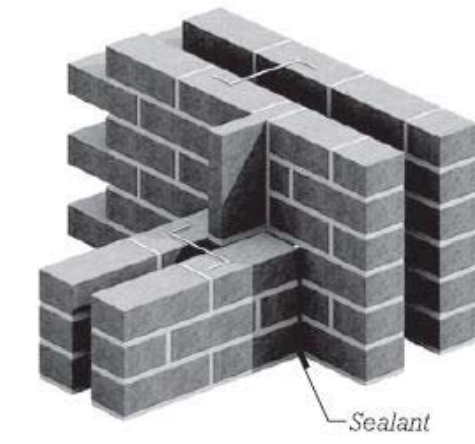
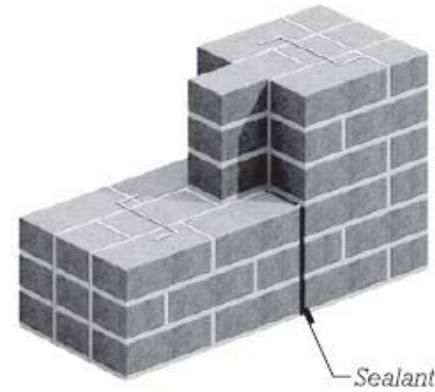
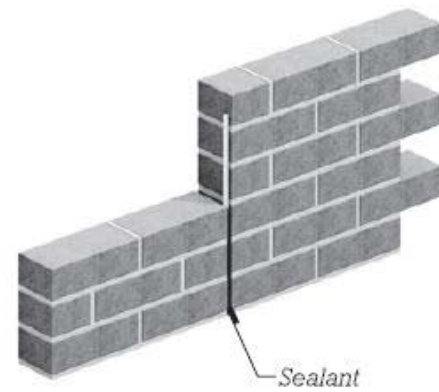
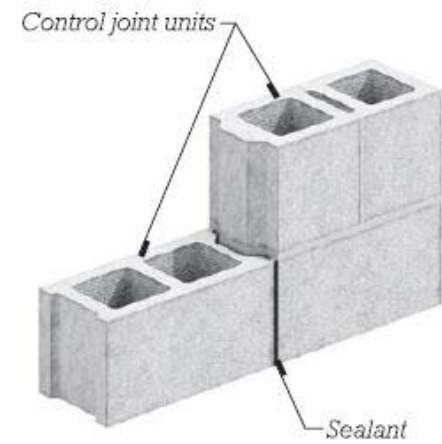
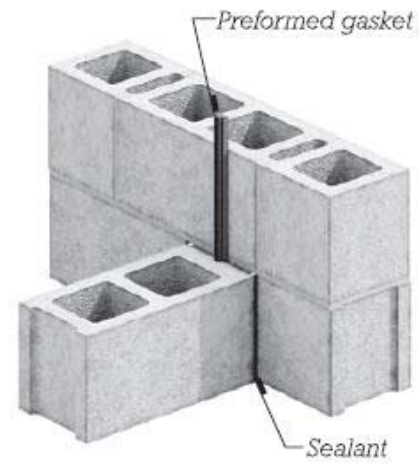
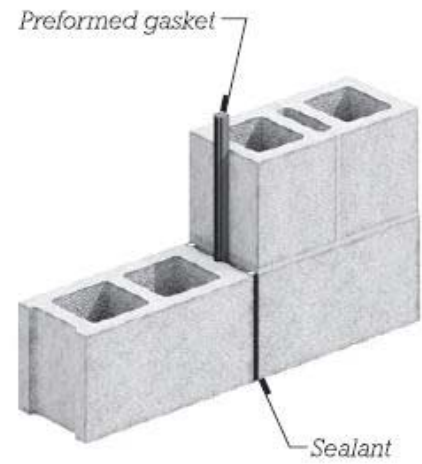
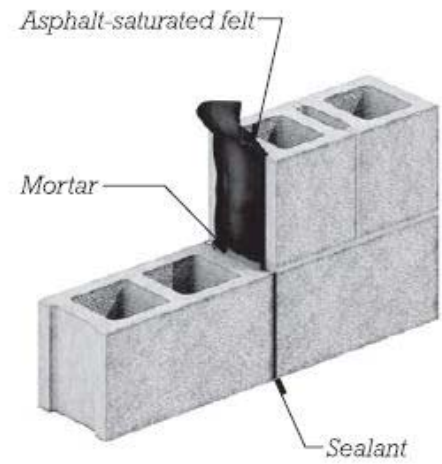

MOVEMENT JOINTS IN BUILDINGS:

- ALLOW PARTS OF THE BUILDING TO MOVE INDEPENDENTLY TO ALLEVIATE INTERNAL STRESSES
- JOINT REINFORCING MUST BE INTERRUPTED AT MOVEMENT JOINTS
- JOINTS MUST BE SEALED WITH FLEXIBLE SEALANTS

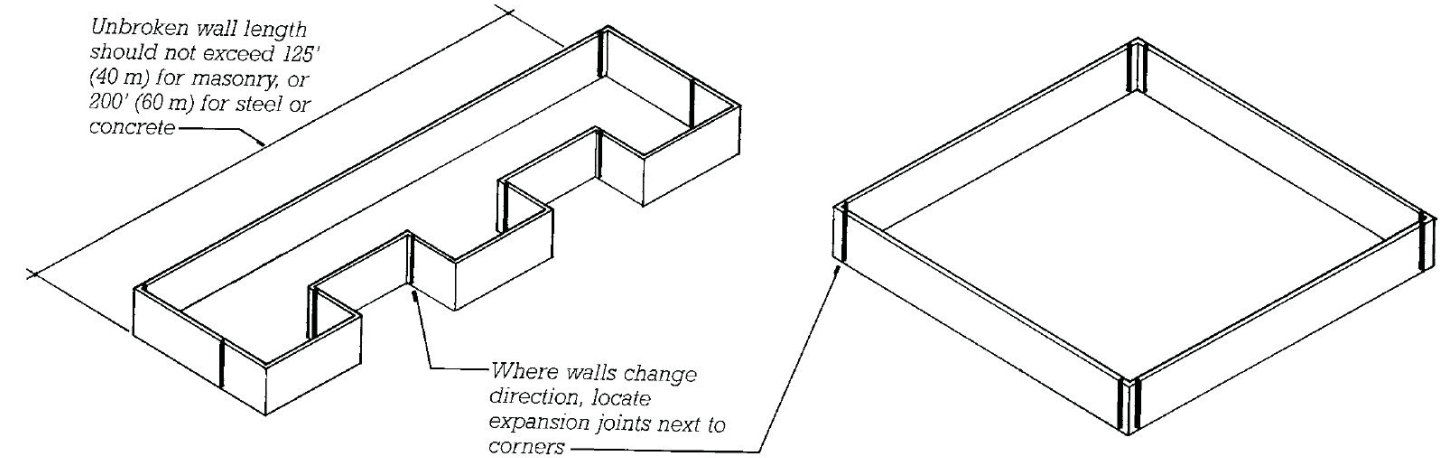

SPECIAL PROBLEMS OF MASONRY CONSTRUCTION

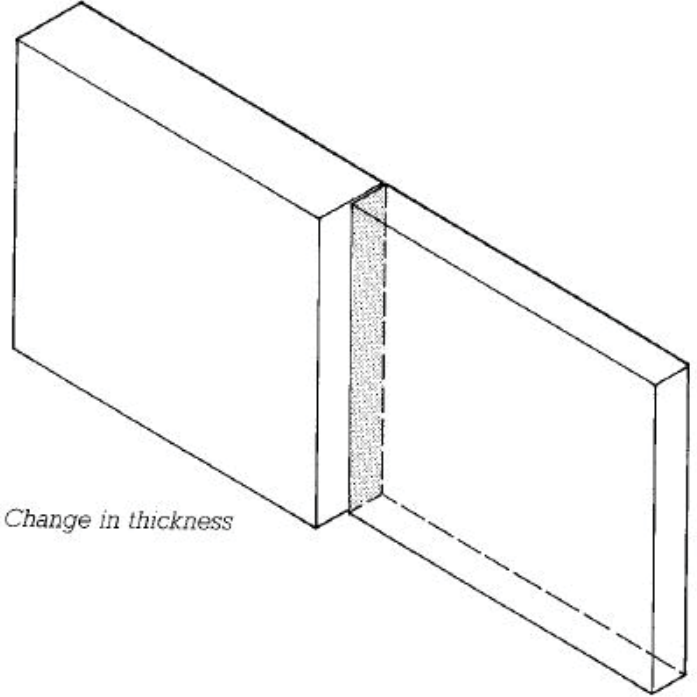
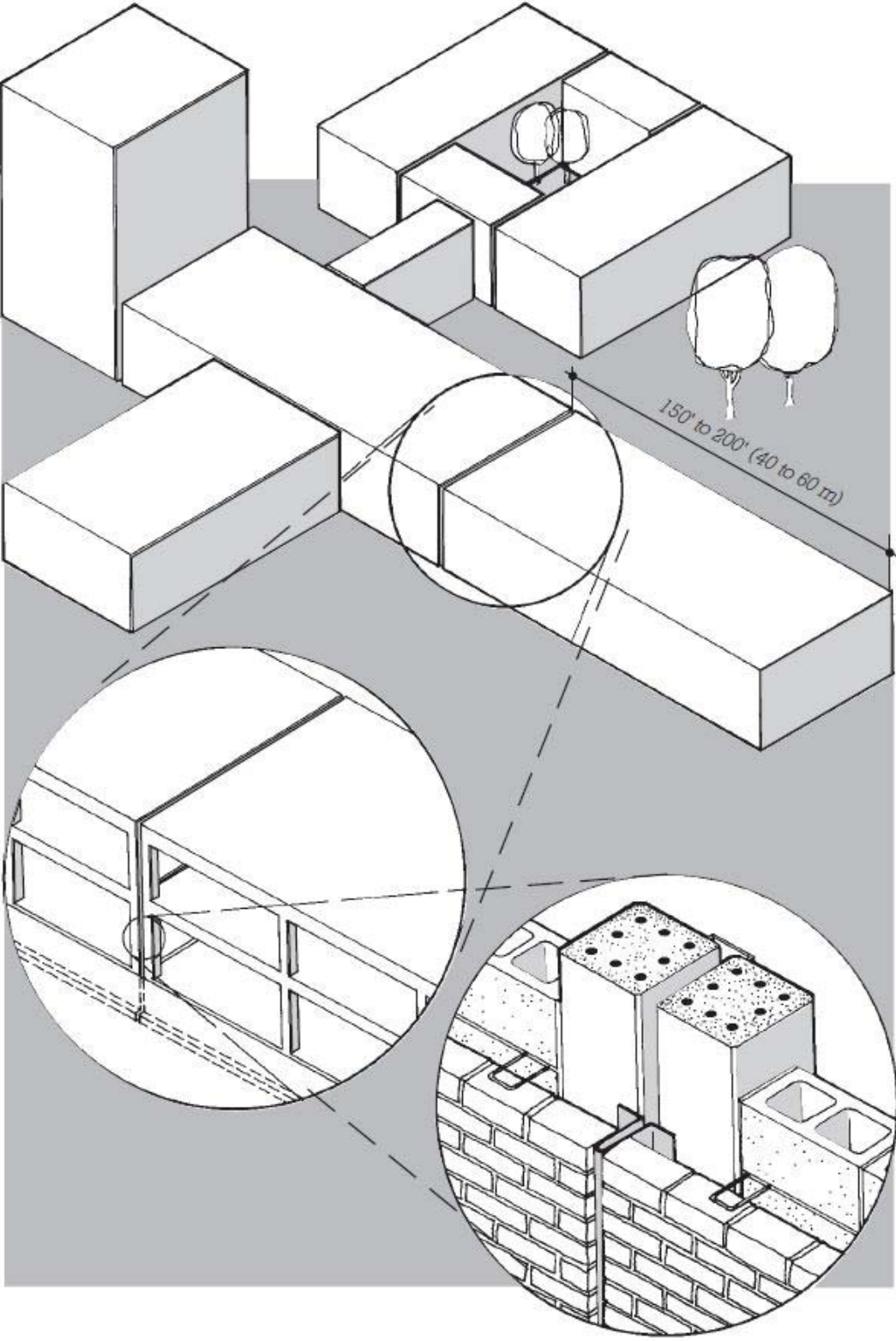

Change in thickness

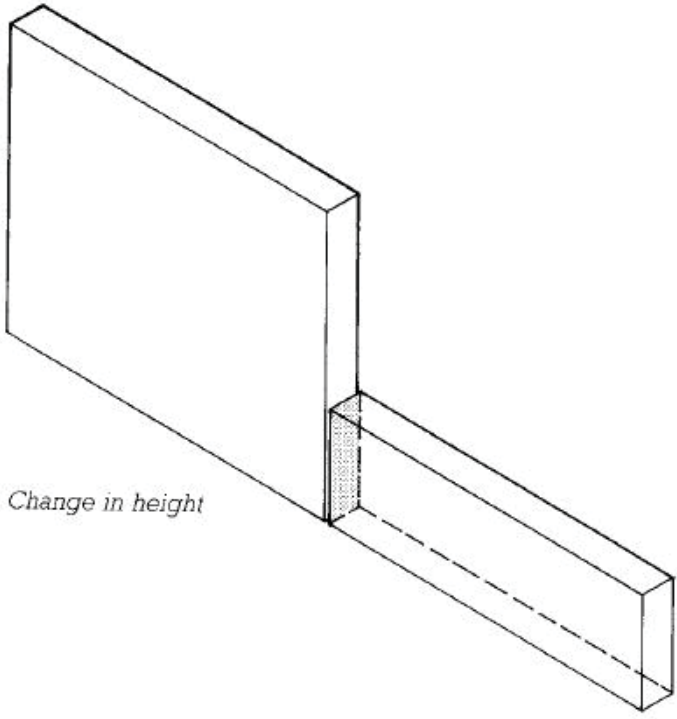

Change in height

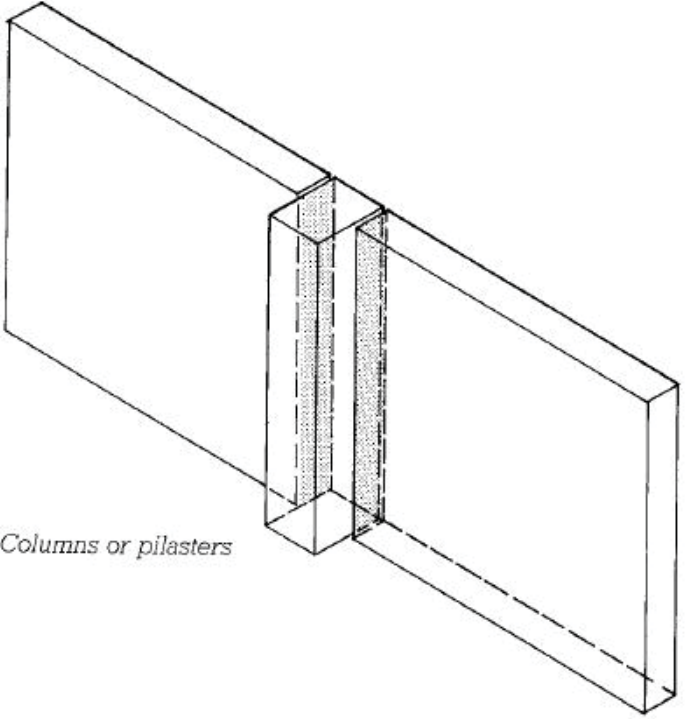

Columns or pilasters

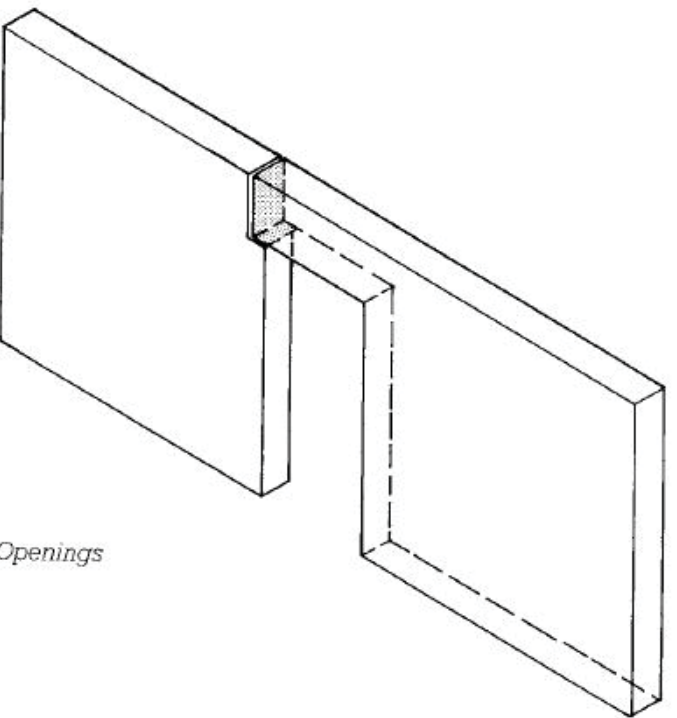

Openings

SPECIAL PROBLEMS OF MASONRY CONSTRUCTION



EFFLORESCENCE:

- SALTS PRESENT IN THE BRICK OR MORTAR THAT SEEPS OUT WHEN THE BRICK ABSORBS WATER
- CHOOSE MATERIALS THAT HAVE BEEN TESTED AND APPROVED

SPECIAL PROBLEMS OF MASONRY CONSTRUCTION



MORTAR JOINT DETERIORATION:

- MORTAR IS THE WEAKEST PART OF THE MASONRY WALL AND DETERIORATES THE QUICKEST
- WEATHER RESISTANT MORTAR SHOULD BE USED AND PACKED TIGHT
- REPOINTING (TUCKPOINTING) SHOULD BE DONE REGULARLY TO MAINTAIN THE WALL

SPECIAL PROBLEMS OF MASONRY CONSTRUCTION



MOISTURE RESISTANCE OF MASONRY:

- MASONRY IS POROUS AND ALLOWS WATER IN
- WATER CAN GET THROUGH MORTAR JOINTS AND CRACKS
- WALLS SHOULD BE SHIELDED FROM EXCESSIVE WATER WHERE POSSIBLE
- CAVITY WALLS SHOULD BE USED
- PAINT, STUCCO, OR CLEAR SEALANTS CAN HELP PREVENT WATER PENETRATION
- BELOW GRADE MASONRY SHOULD BE PARGED AND COVERED WITH A WATERPROOFING MEMBRANE



SPECIAL PROBLEMS OF MASONRY CONSTRUCTION

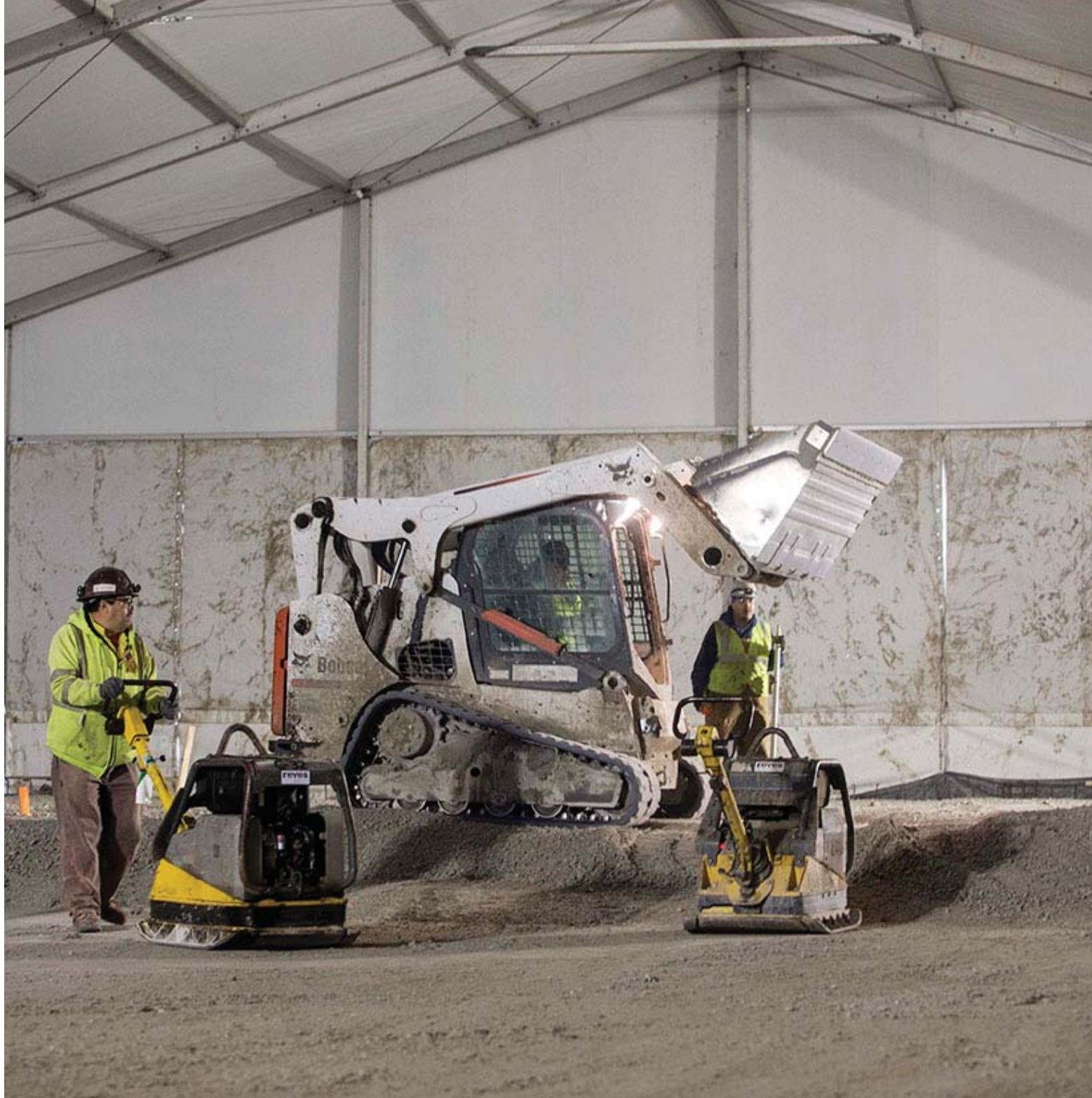

COLD AND HOT WEATHER CONSTRUCTION:

- MORTAR CANNOT FREEZE BEFORE IT CURES OR ITS STRENGTH AND WATER RESISTANCE WILL BE REDUCED
- IF TOO HOT, MORTAR CAN DRY BEFORE IT CURES – ALSO PROBLEMATIC
- TEMPORARY ENCLOSURES FOR 2-3 DAYS AFTER INSTALL FOR CURING

MASONRY AND THE BUILDING CODES



- MASONRY IS NON-COMBUSTIBLE, SO IT CAN BE USED IN MANY TYPES OF BUILDINGS
- CAN ALSO BE USED IN FIRE SEPARATION PARTITIONS
- BECAUSE OF MASS, GOOD AT ABSORBING SOUND AS WELL

UNIQUENESS OF MASONRY



- REMINISCENT OF BUILDINGS FROM THE PAST – POSITIVE ASSOCIATIONS, PERMANENCE / SOLIDITY
- MANY COLORS / TEXTURES / PATTERNS POSSIBLE
- NON-COMBUSTIBLE AND FIRE-RESISTANT
- ECONOMICAL
- LABOR INTENSIVE – BUT CAN BE DONE WITH A SINGLE TRADE (LESS COORDINATION)
- GENERALLY REQUIRES SMALL, CHEAP EQUIPMENT
- USES STANDARDIZED MATERIAL UNITS, SO GENERALLY DOES NOT REQUIRE A LOT OF PREP WORK