



AV System Design for LSS

Alejandro Suquisupa

Background of LSS

- Stage Lighting Super Saturday is a lighting convention
- 2019 & 2020 event held at City Tech
- This year was its 15th year
- Presenters such as
 - Ken Billington
 - Jennifer Tipton
 - Natasha Katz
 - Chip Scott
 - John Huntington

Role

- AV system design – Designing the system flow for both systems
- Lead AV crew – Being the one in charge and leading the crew to completion
- FOH Mixer – Mixing the event between presenters and host



Deliverables

- AV signal flow
- Input/Output list
- Inventory list
- Com design
- Fully functional system

Calendar for January & February

Sunday	Monday	Tuesday	Wednesday	Thursday	Friday	Saturday
			1	2	3	4
5	6	7	8	9	10	11
12	13	14	15	16	17	18
	LSS Meeting: 11am – 12pm		Video System Test			
19	20	21	22	23	24	25
				Video System test with John Huntington 5:30pm – 7pm 03	LSS AV Work call 10am – 6pm	
26	27	28	29	30	31	1
		AV Tech Production: Inform crew of AV signal flow		AV Tech Production: Label cables, test inputs, run com	LSS Load In: Set up video station, prep mics, test RF mics with Scott	LSS Event: 7am – 6pm, video Strike
2	3	4	5	6	7	8
		AV Tech Production: Strike Rio 3224, com, RF, projector cables				

Challenges

- Understanding video systems
- Leading a crew for the first time
- Inventory changes
- Resolution issues

Audio Process

- Digital system using Dante
- Stagebox downstage to Rio 3224 in Upstage left room
- Talkback, host, podium, and headset mics
- Used Dugan Automixer for talkback
- RCF Line array donation



Audio Signal Flow

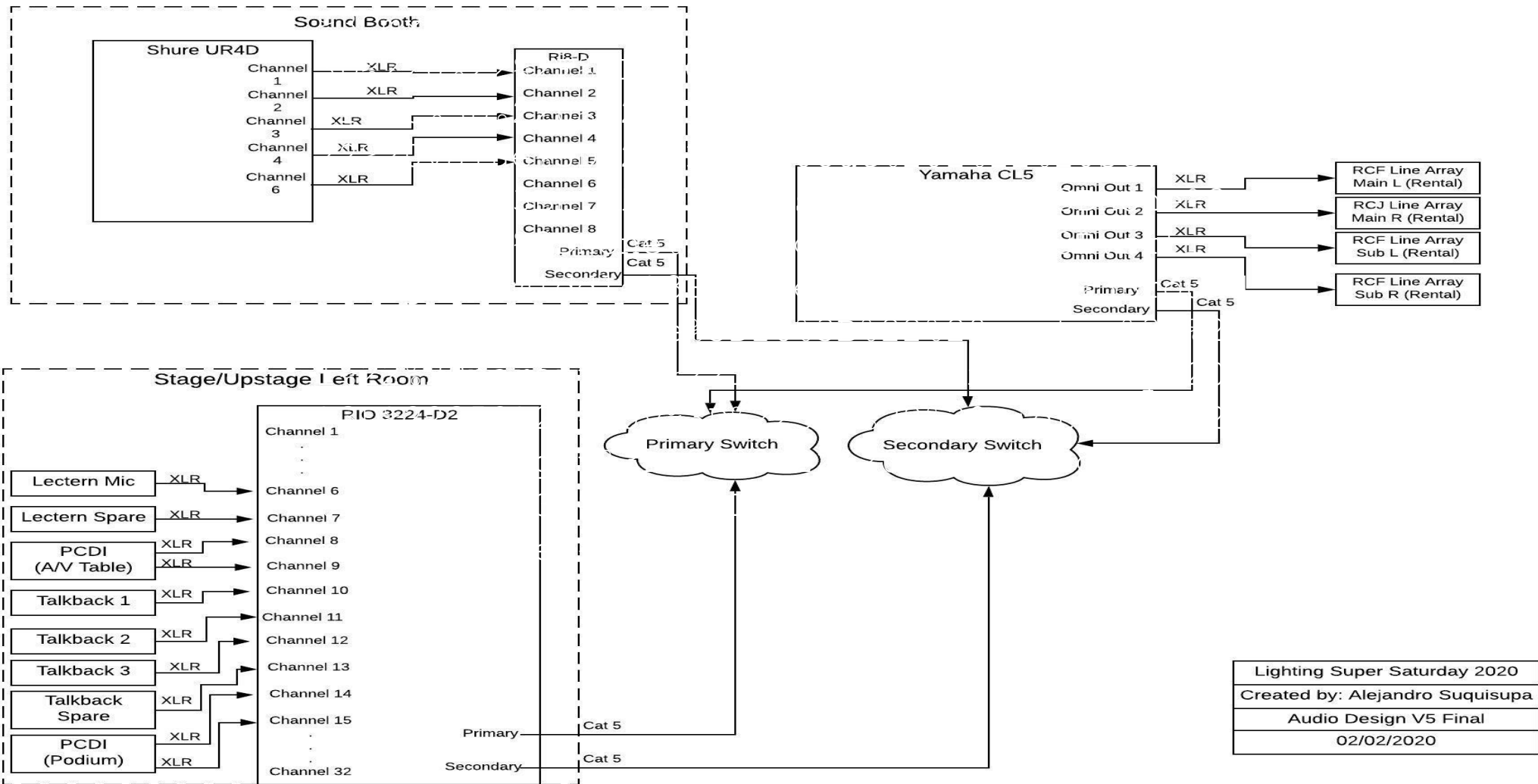

Lighting Super Saturday 2020
Created by: Alejandro Suquisupa
Audio Design V5 Final
02/02/2020

Video Process

- Used ATEM Television Studio HD
- Switched between presenter laptop and our computer
- Lumantex helped us scale to ATEM resolution
- HDMI splitter for ATEM and monitor
- Panasonic projector rental from WorldStage



Video Signal Flow

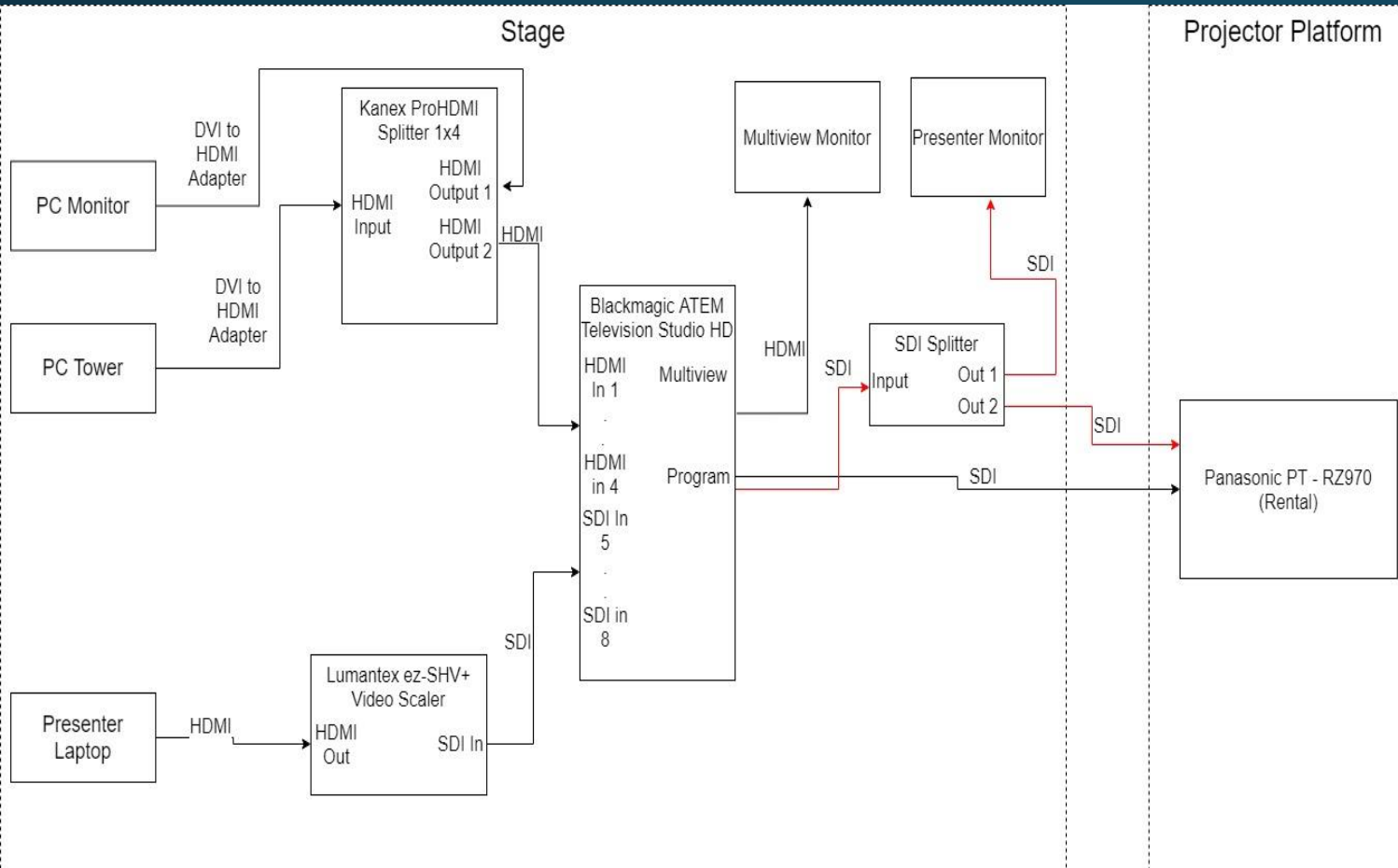

Lighting Super Saturday 2020
 Created by: Alejandro Suquisupa
 Video Design V7 Final
 05/08/2020

Learning Outcomes

- Better understandings of video systems
- Delegating a crew
- Learning the Dugan
- Working with a line array
- A1, Production Audio/Crew Lead, System Design
- Conference/corporate experience

Recommendations

- Monitor by presenter to see their presentation
- If on schedule, to come later the day before the event
- Bigger table for video

Acknowledgements

- ENT Department
- John Huntington
- AV Tech Production Crew
- Volunteer Crew
- RCF
- World Stage