



Lighting Super Saturday AV System Design

Alejandro Suquisupa – AV Designer

Department of Entertainment Technology

Introduction

Lighting Super Saturday is a lighting convention that has been going on for 15 years. It hosts many different people in the lighting industry such as designers, vendors, and others. For this event what they need from us are a few mics, a projector, and a video switcher to project the presenter laptop and our computer which has a logo of the event between presenters or on break. The role that I will play for this event is AV designer, leading the AV crew, and being FOH mixer for this event.

Deliverables

- Inventory list
- Input list
- Output list
- Audio diagram
- Video diagram

The Process

In order for the event to happen there needs to be documentation. The documentation that is provided for the event is an inventory list, AV diagram, and an input/output list. What was followed after was testing the video system. Me and Professor Huntington came in one day during the winter break to test the video system and realized some flaws with the switcher. The switcher could only be set to one resolution which meant if one laptop/computer has a higher/lower resolution than the other then it would not be able to be projected. So we had to get some scalars that would adjust its resolution so that it could be projected. After that then it was time to set up the event with the help of some volunteers and the AV crew.

Audio System Flow

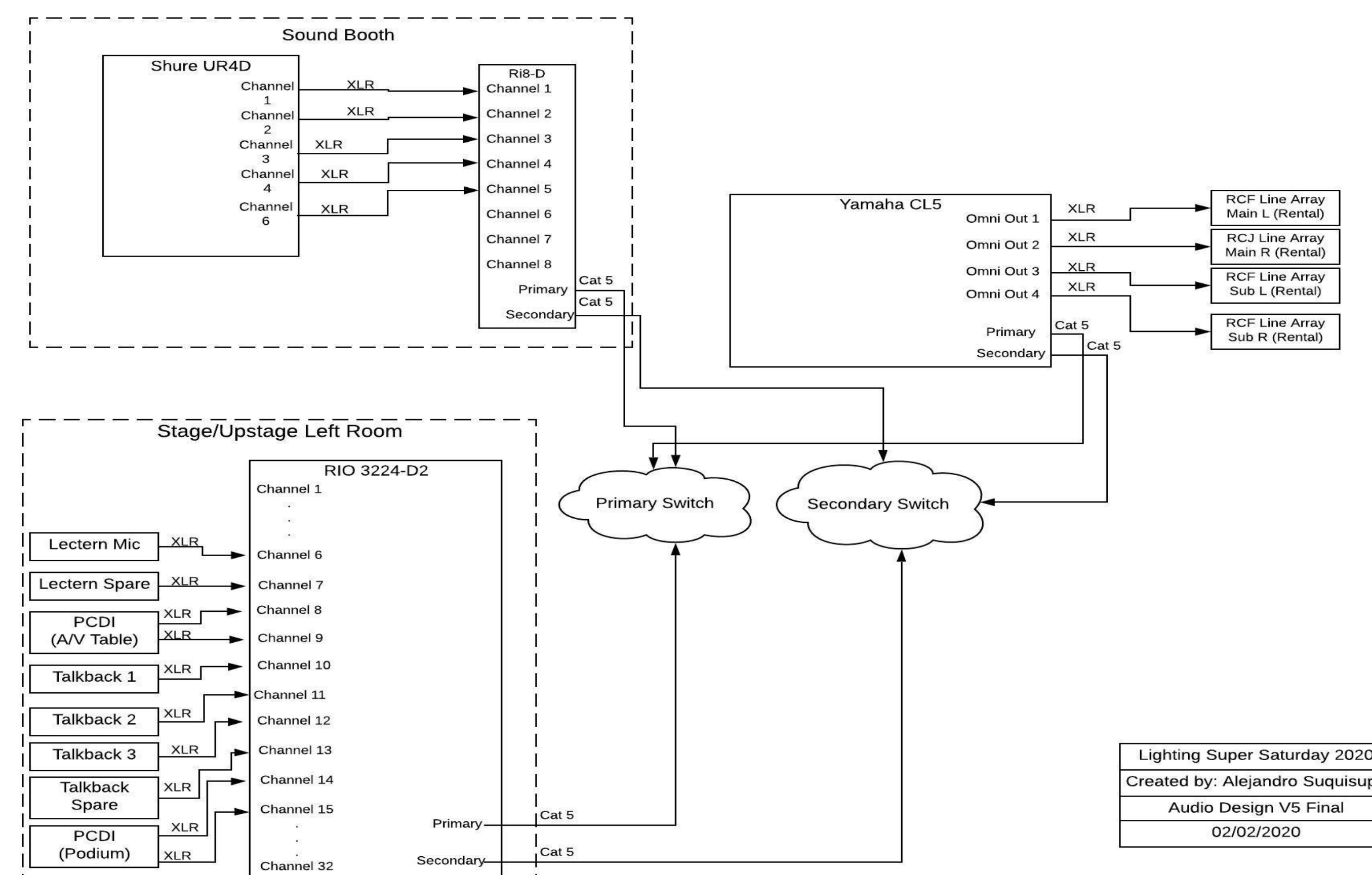

Conclusion

Lighting Super Saturday was a great experience. It gave me the chance to design an AV system and a chance to lead the crew. Later on down the road I would like to be the one to lead a crew or just have someone ask me questions about the system and being able to help them would be a gratifying moment for me. This is definitely a step in the right direction. The event ran smoothly, Scott the host of the event seemed very pleased with how the event went. There were some changes along the way such as we were able to rent a really nice projector that World Stage provided. I changed the video design a bit but it wasn't anything terrible. It was a great opportunity to be able to design this event.

Video System Flow

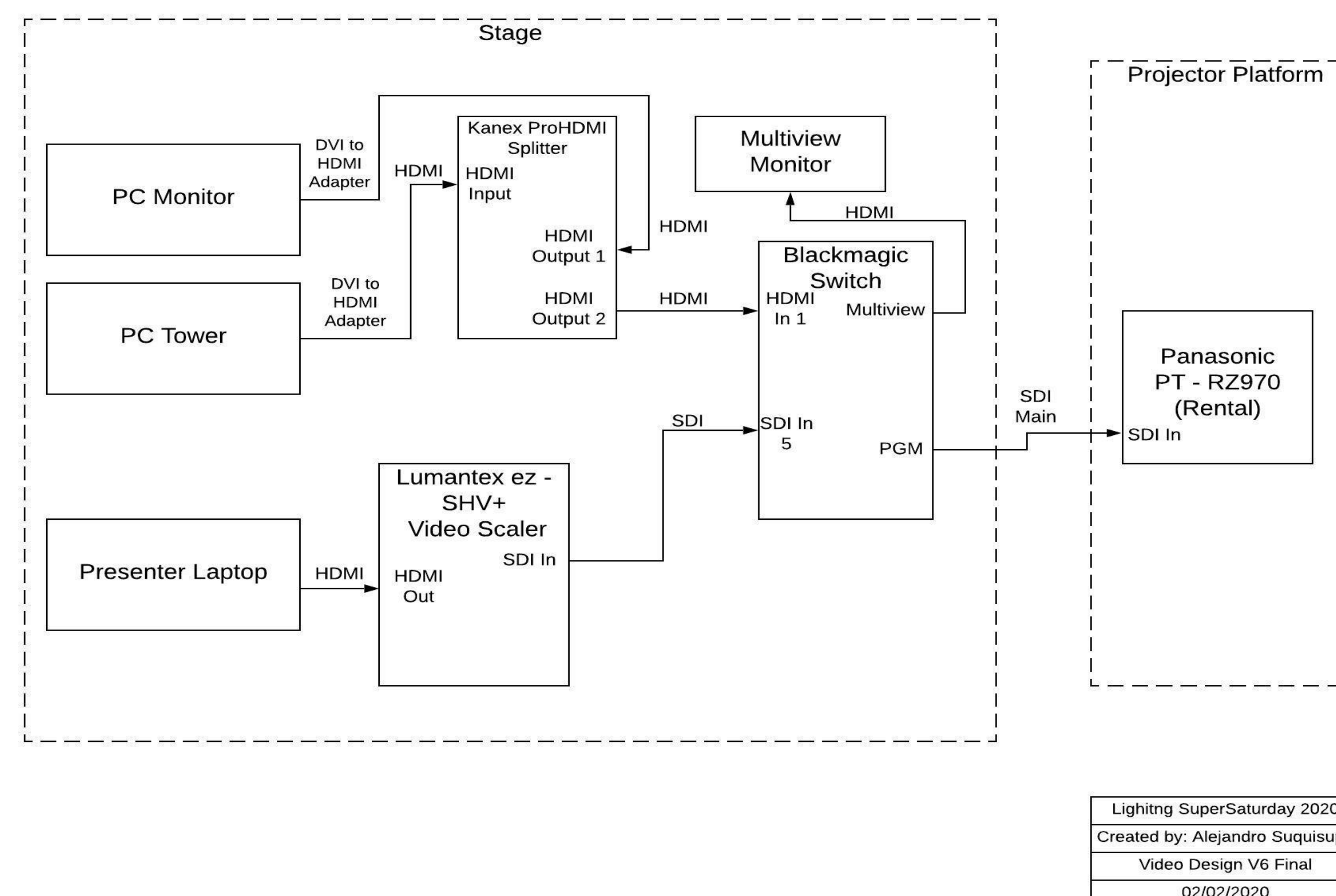

Acknowledgements

- John Huntington
- ENT Department
- World Stage
- RCF
- AV Tech Production Crew