

COLLAGES AND MODELS

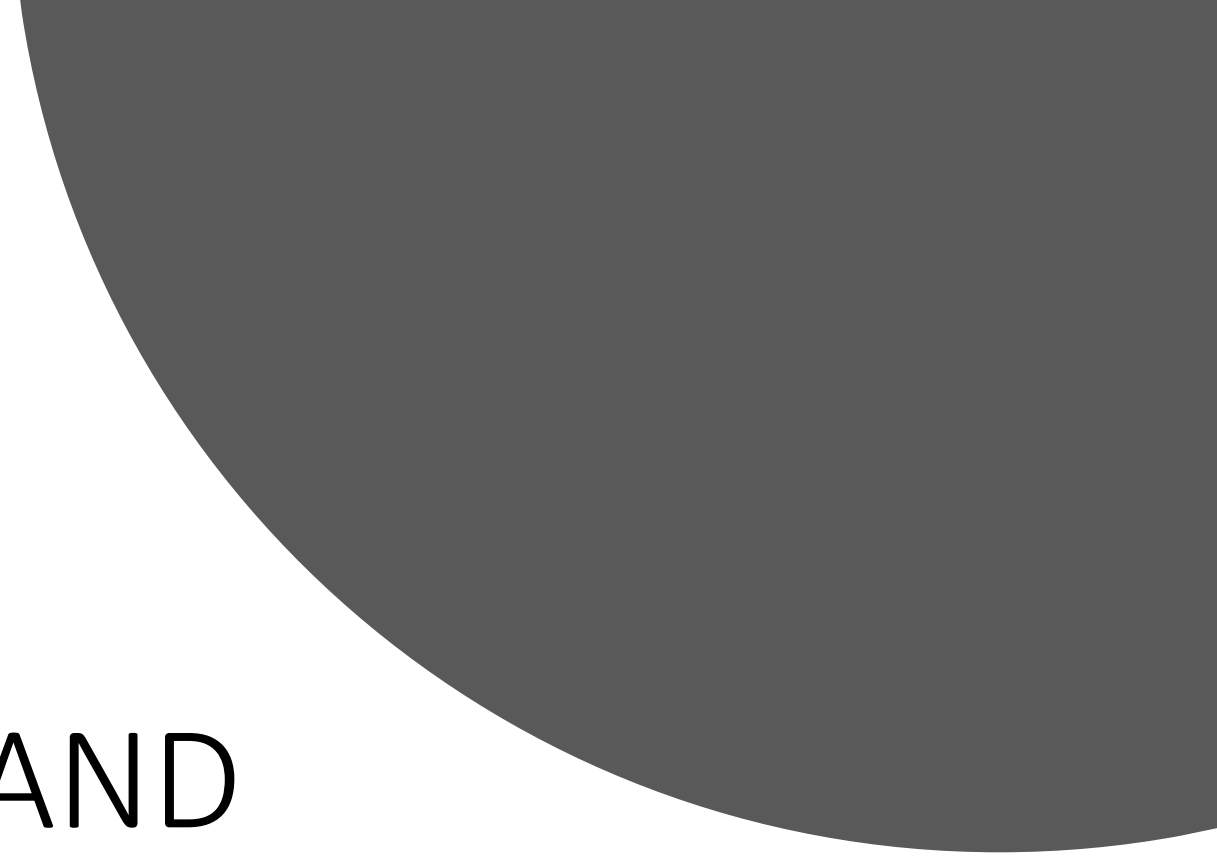

ASSOCIATED MODELS

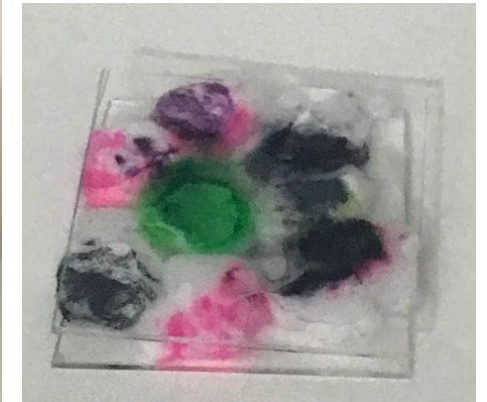
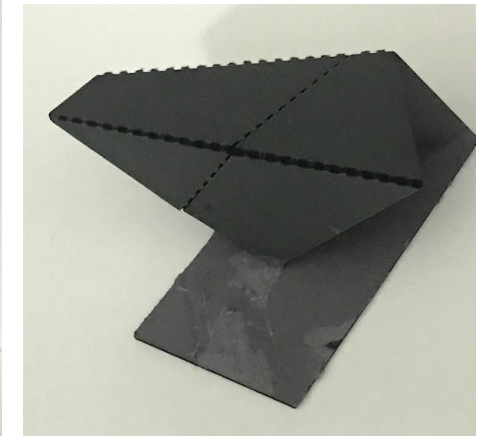

SITE INTERPRETATION

Disappointment hit me hard when I arrived on the site for the first time. I was aware that there was the canal running through the area and that brought excitement but seeing how polluted and smelly it was felt like wasted potential. The bridge was unstable and walking on it felt like I was going to fall off at any minute and it wasn't like I would be falling into clean water. Overall the experience was a bit scary, and the day we went it was cold and dreary outside. Yet, there is great potential still for the site, signified by the colour within an otherwise dark area. Just a clean canal would make a huge impact.

ASSOCIATED MODELS

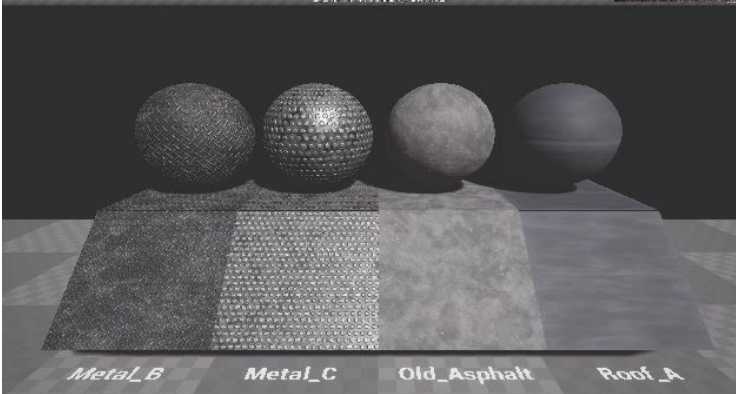
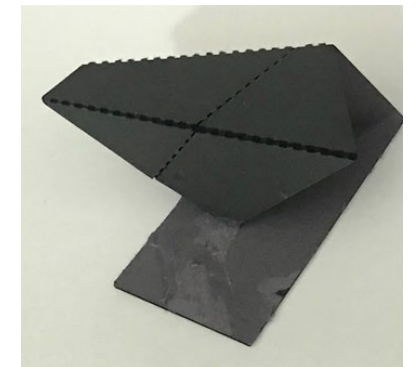
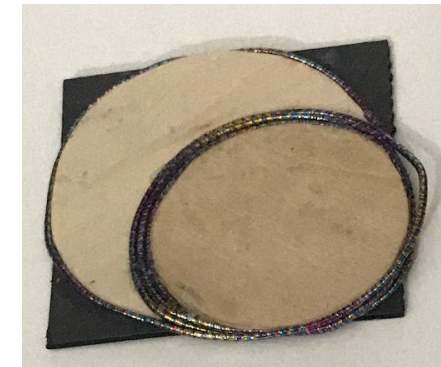
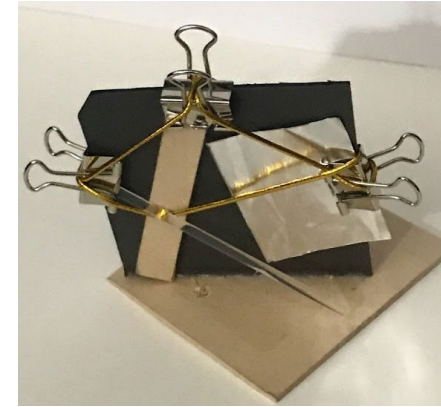

MATERIALS

Gowanus has a historic, industrial, and artistic feel from its materials. There are many brick exterior walls but many of them, nearest the site especially, are covered in graffiti. There is also steel and dark-to-grey toned materials like steel, concrete etc.



ASSOCIATED MODELS

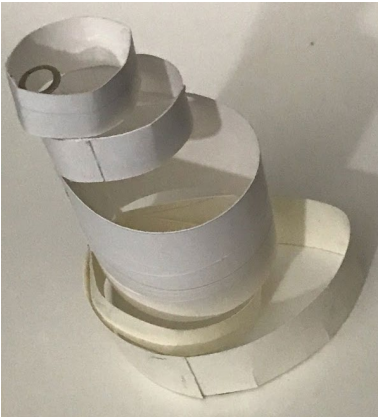
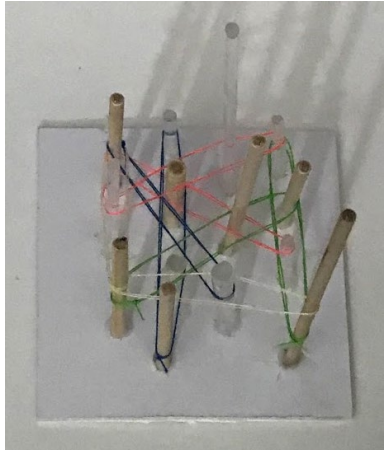

THEME

Grenadian carnival is form of artistic expression and fun. It is rich in bright colours, fashion, dance, music and so much more. There is also something pure and peaceful about it all. It is a form of expression for the people; a chance to enjoy their homeland. Movement plays a huge role in the festivities and energy bounces from person to person and bodies move all over the place.

MASSING DIAGRAM

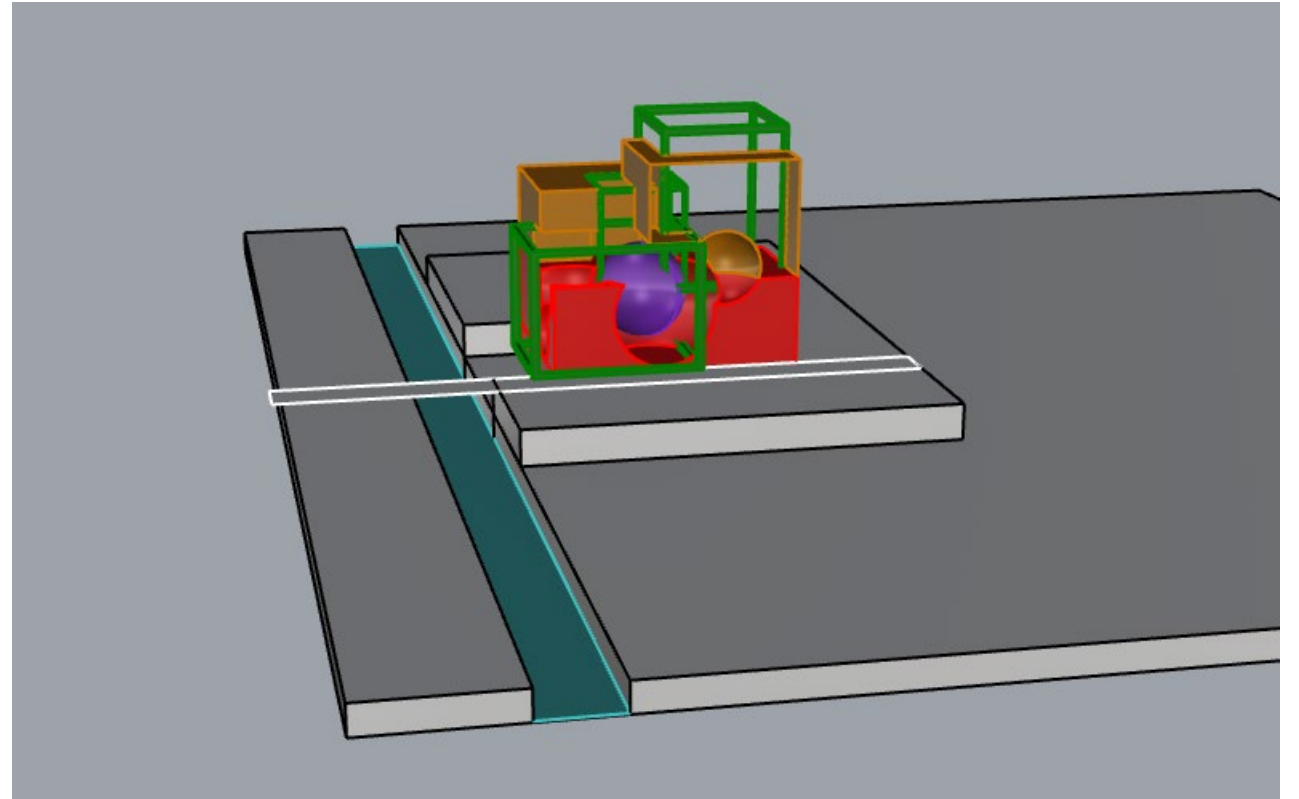
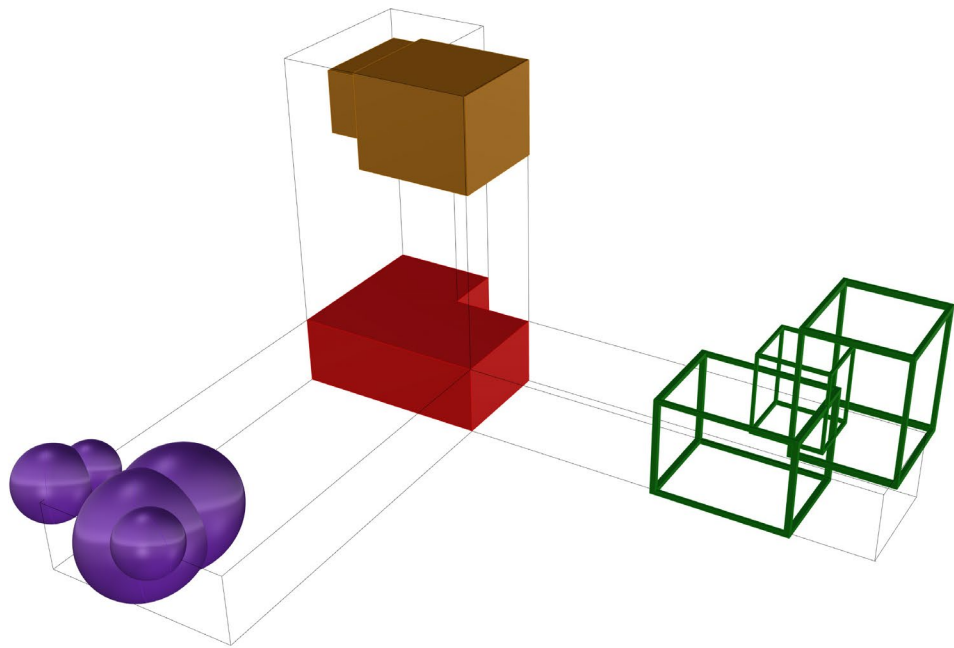

HYBRID MODEL

