

# PRELIMINARY FAÇADE MATERIALS PRESENTATION

OUSMANE CAMARA

BTECH III

ARCH: 2431

PROFESSOR: SHERMAN

SPRING 2020

GROUP: DOLMA, ALBIJON AND DRE-NICA

**OPAQUE FAÇADE/METAL CLADDING PANEL**

**GUGGENHEIM MUSEUM BILBAO**



# HOW DOES IT FUNCTION STRUCTURALLY?

Metal cladding is a type of exterior cladding made of metal. Exterior cladding is basically the protective outer covering on buildings. It's a term used to describe exterior surfaces on things like walls, windows, doors, and trims.

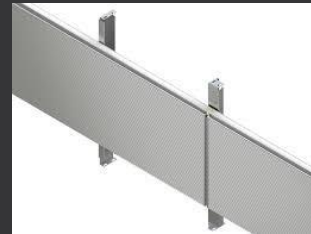

Cladding systems are external surfaces attached to a building's façade, generating an airtight structure. Their main goal is to protect buildings from weather conditions such as strong winds and heavy snow.

# HOW DOES IT PROVIDE THERMAL RESISTANCE?

Assessing thermal performance of built-up metal roof and wall cladding systems using rail and bracket spacers

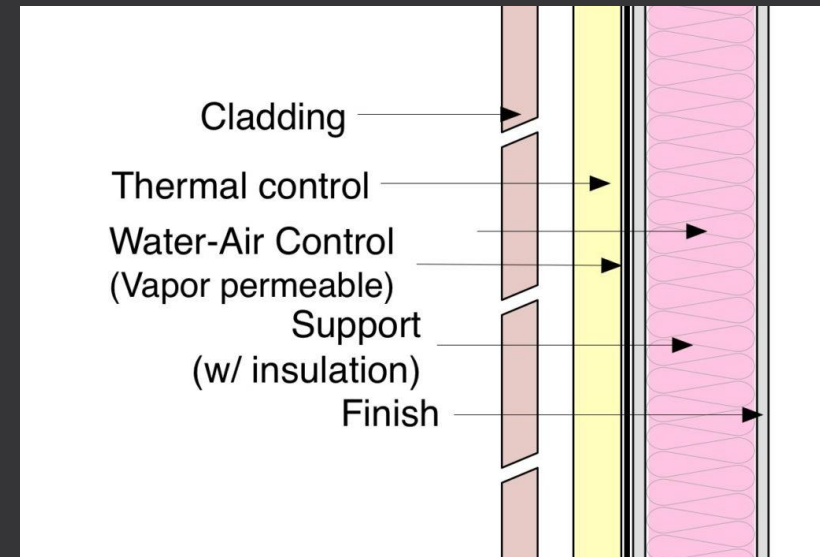
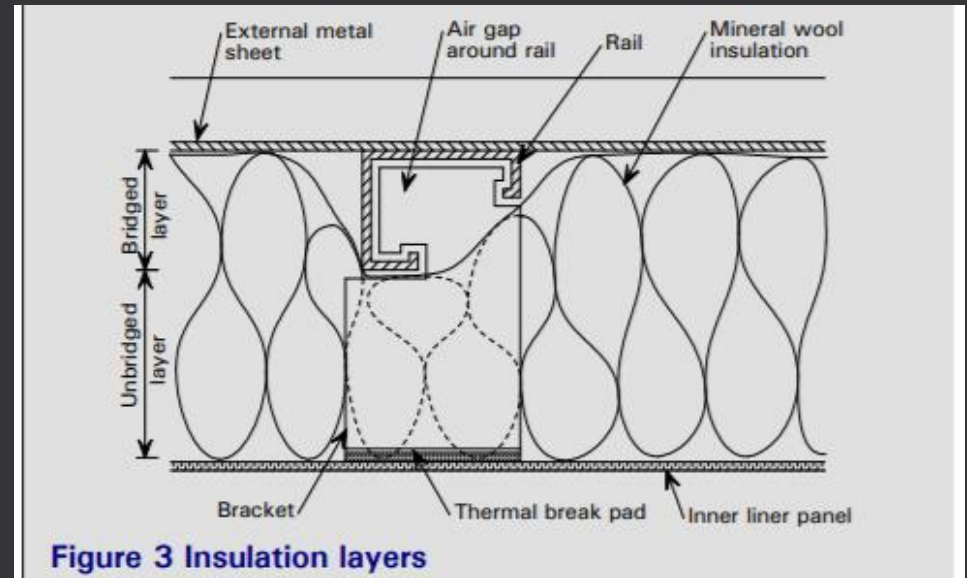
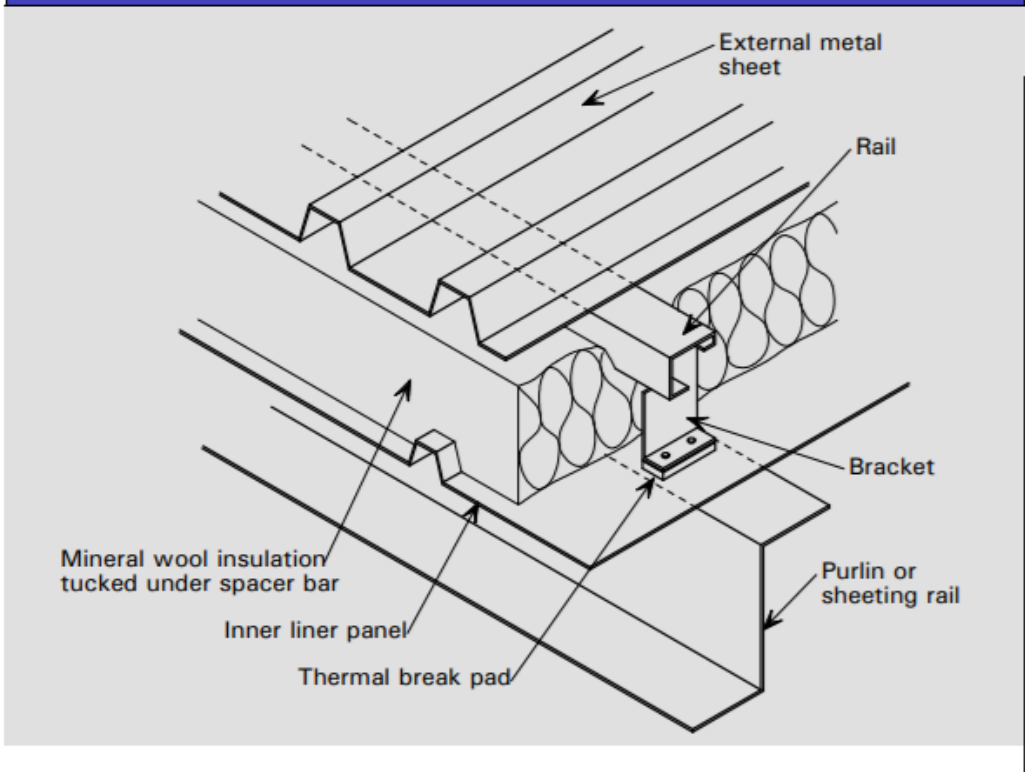

# HOW DOES IT WATERPROOF THE BUILDING?

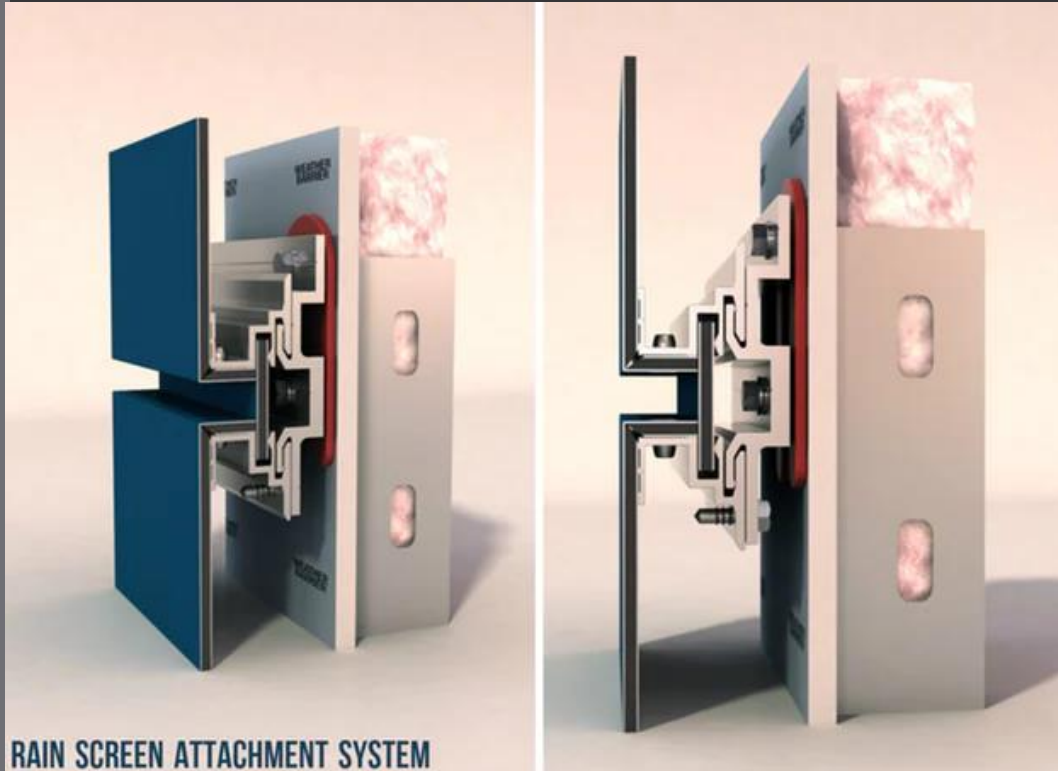

Rainscreen cladding is a form of weather cladding designed to protect against the elements, but also offers thermal insulation. The cladding does not itself need to be waterproof, merely a control element: it may serve only to direct water or wind safely away in order to control run off and prevent its infiltration into the building structure. Cladding may also be a control element for noise, either entering or escaping. Cladding can become a fire risk by design or material.



# CURTAIN WALL/GLASS CABLE WALL

Gardenia, Tropical Garden, Helsinki, Finland



# HOW DOES IT FUNCTION STRUCTURALLY?

## Glass Systems

Glass can be used to create building interiors which connect occupants with the external environment, combining unbroken views of the surrounding nature and high level of natural light with the comfort and safety of the internal environment.



### Advanced Glazing Systems

- Insulating laminated glass units serve as roof
- Laminated glass fins serve as beams
- Vertical rods take the load from the fins
- Vertical rods transfer load to cables which in turn transfers it to steel trusses
- Vertical rods take the load from the fins
- Vertical rods transfer load to cables which in turn transfers it to the steel trusses
- Upward arching cables provide wind uplift resistance
- The glass wall obtains additional stiffness where the cable system is tied to adjacent columns.



# HOW DOES IT PROVIDE THERMAL RESISTANCE?

Low-e glass reduces the heat loss of the building by:

(1) **Reflecting** the energy emitted by room heaters and surfaces back into the room (long wave radiation).

(2) **Allowing high transmission** of the solar radiation (short wave radiation) through the glass to benefit from passive solar heat gain through the glass.

During the winter, low-emissivity (low-e) glass can reduce heat loss while allowing high levels of valuable free solar gain to heat buildings with no significant loss in natural light.

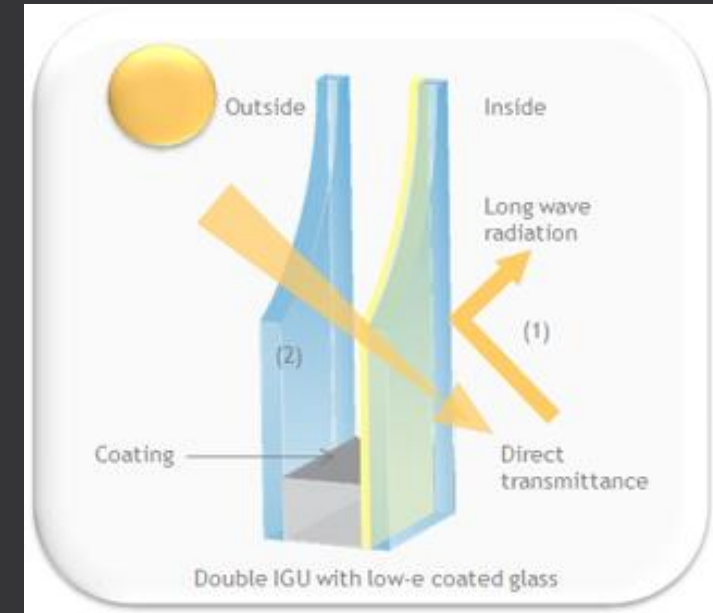

Pilkington Low-E 4th Surface Technology allows double-glazed insulated glass units to achieve better thermal performance. Applying two pyrolytic low-e lites in an insulated glass unit reduces the center-of-glass u-factor by 45%, compared to a unit with two panes of standard clear glass.

- In cold weather conditions, the pyrolytic low-e coating on the #2 surface reduces room heat from transferring across the airspace toward the outside. By adding a second low-e coating to the #4 surface the thermal insulation is improved.
- A low-e coating on the #4 surface reflects room heat, back inside in cold weather conditions. This reduces the radiant heat loss and improves the overall insulation of the unit.



# HOW DOES IT WATERPROOF THE BUILDING?

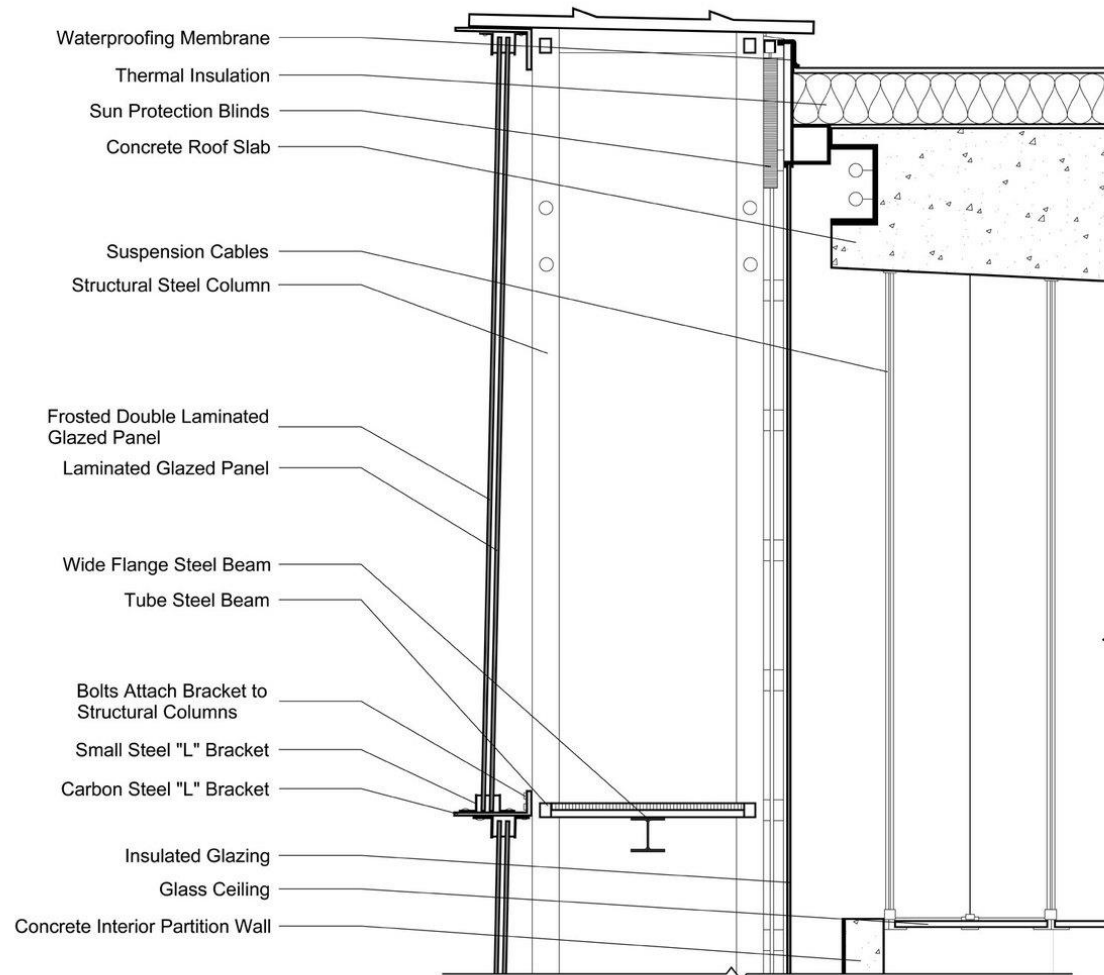

The waterproof type building wall is characterized by comprising a bearing wall body, a vacuum glass layer, inner decorative glasses, a wire channel, a water pipe channel and fixing racks. The outer side of the bearing wall body is fixedly connected with the waterproof layer, the inner side of the bearing wall body is fixedly connected with the vacuum glass layer, the top end of the bearing wall body is provided with the wire channel, and the bottom end of the bearing wall body is provided with the water pipe channel; the inner decorative glasses are fixedly connected with the vacuum glass layer through the fixing racks. Compared with the prior art, the waterproof, heat preservation and insulation and noise reduction type building wall has the advantages of waterproofness, heat preservation, thermal insulation, noise reduction, simple operation and cleaning convenience.

# SOURCES

<https://www.hendrickcorp.com/architectural/products/arch-cladding/>

<https://www.pilkington.com/en/us/products/product-categories/glass-systems/pilkington-planar>

<https://www.youtube.com/channel/UCk92doIPWzchb4rtxscTBww>

<https://www.youtube.com/watch?v=NWwiGGSBErY>