

Structure, Thermal, Waterproofing

Hubert Szpin
Building Technology 3
Prof. King
Spring 2020

Material Selection

Opaque Material

Name: Concrete Skin

Manufacturer: RIEDER

Glass Curtain Wall

Name: 1600UT System 1 Curtain Wall

Manufacturer: KAWNEER



Concrete Skin

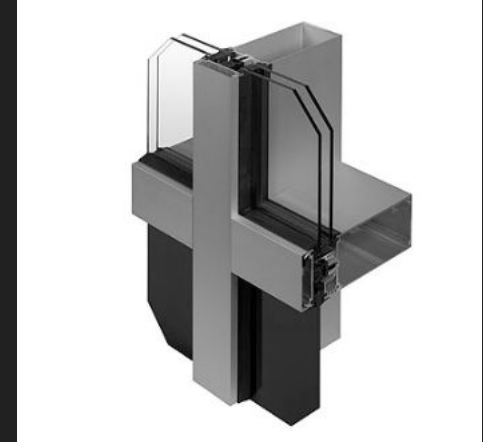

1600UT Sys. 1

Opaque - Concrete Skin

Concrete Skin is a panel that is applicable to exterior building facades.

Performance: The manufacturer claims the panels can “withstand extreme loads with enormous panel sizes.”

Mounting: These panels are suspended or hung on a “ventilated facade system” with the benefits of building physics, ecology, economy.

This material is Fireproof and Sustainable.

This product's greatest selling point is multi color array of options as well as material textures, providing architects with endless possibilities of exterior facade combinations

Opaque - Case Study

University of Ottawa / KWC Architects + Diamond Schmitt



Structural Performance

The facade is designed to work as a ventilated rainscreen. Panels are joined together with a metal clip that is hung on horizontal rails which allow different panel sizes to be moved and re-orientated.

These horizontal members attach to vertical posts by the usage of L brackets

Vertical members are connected to the load bearing wall through the usage of the same L bracket but first come in contact with a thermal break between structural wall and bracket. All members are screwed together using appropriate material screws or connectors.

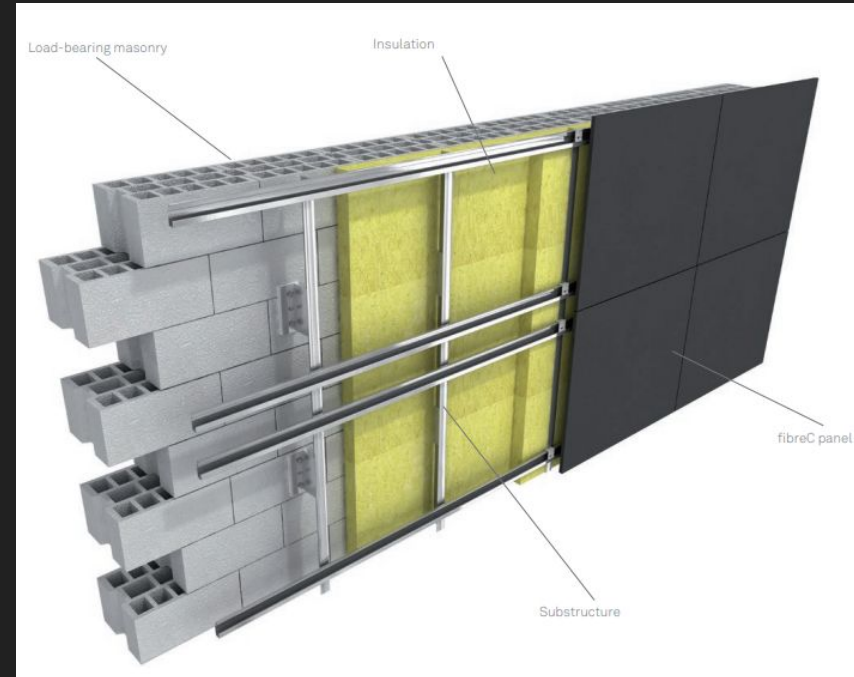

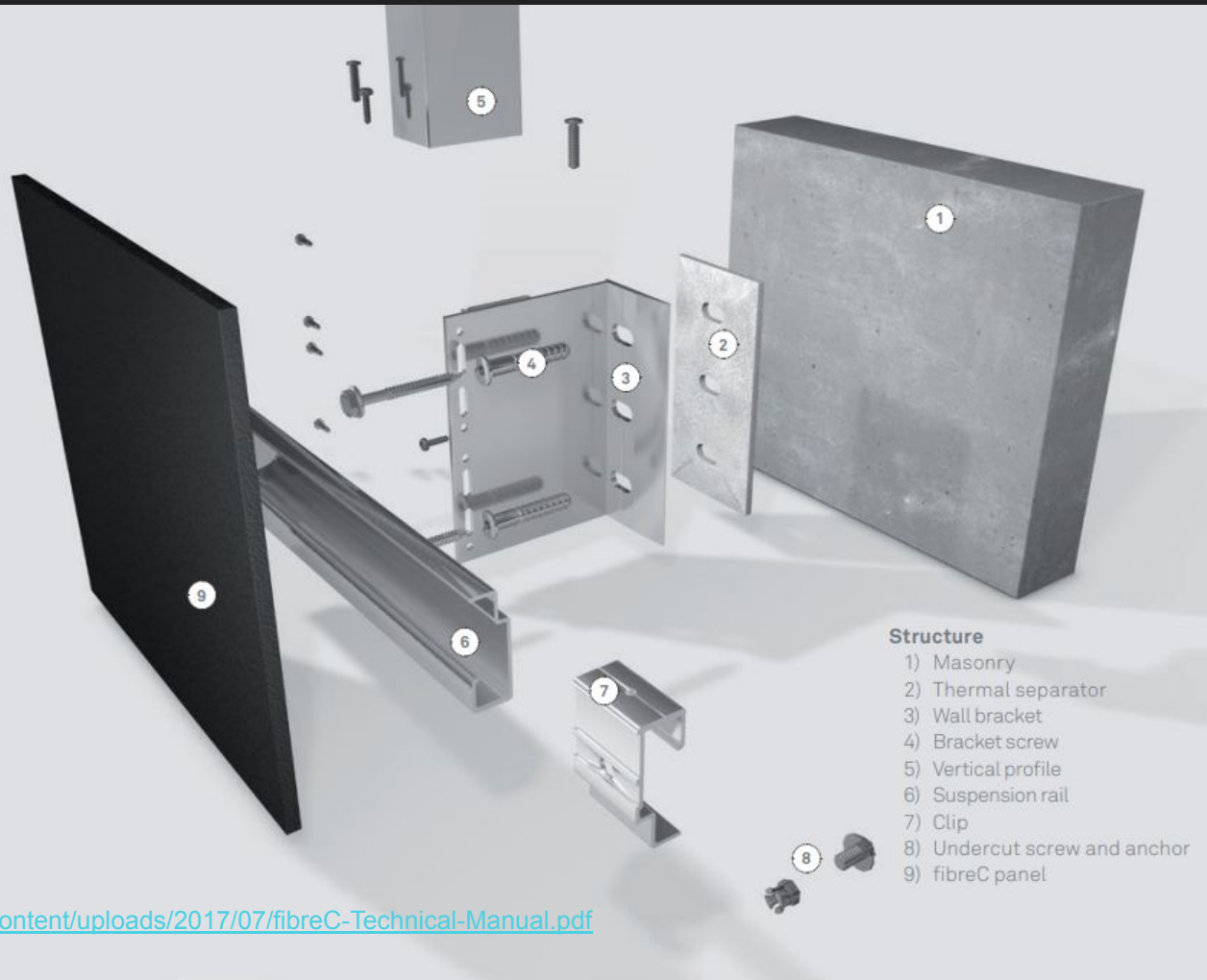

Structure

- 1) Masonry
- 2) Thermal separator
- 3) Wall bracket
- 4) Bracket screw
- 5) Vertical profile
- 6) Suspension rail
- 7) Clip
- 8) Undercut screw and anchor
- 9) fibreC panel

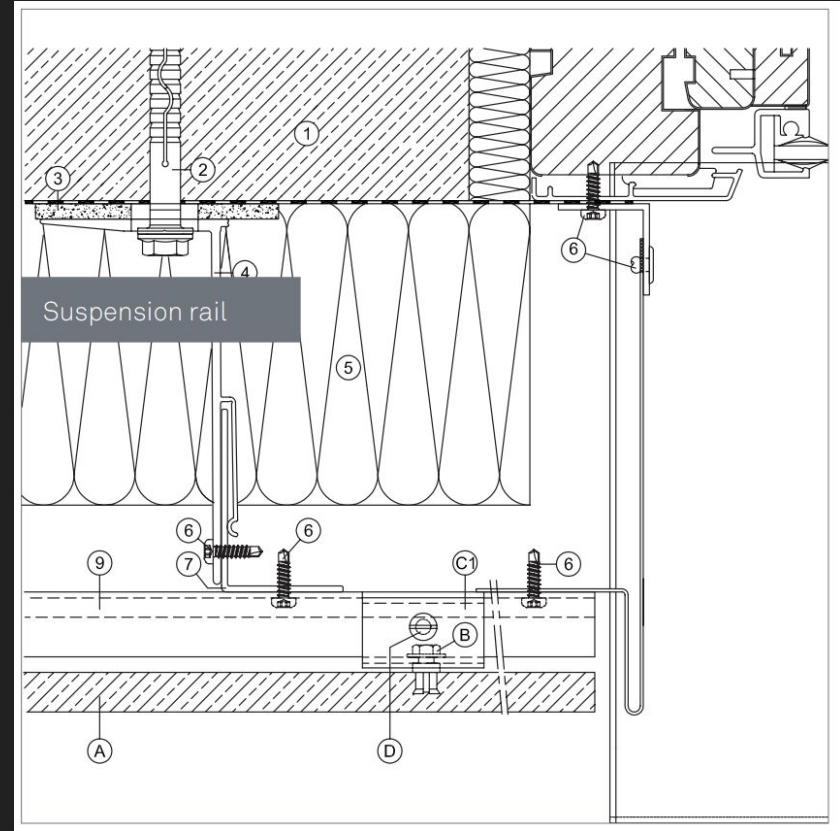
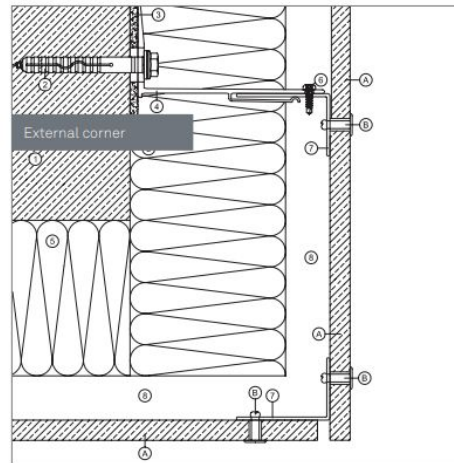
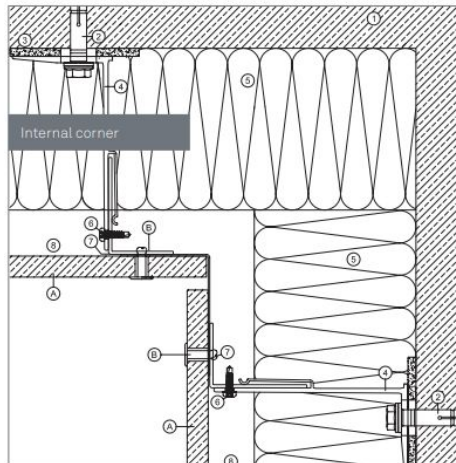
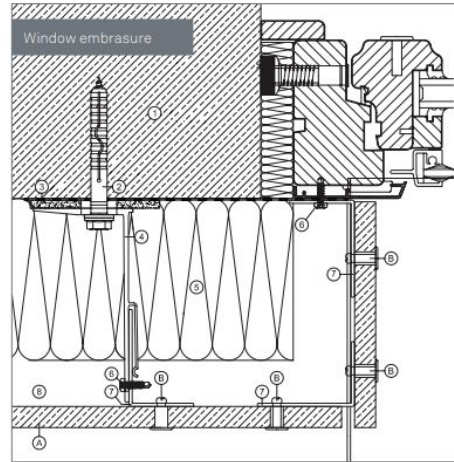
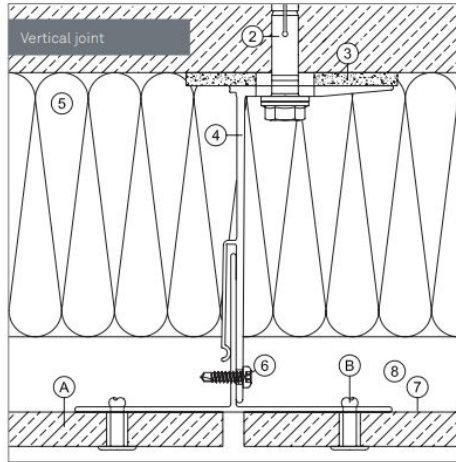

Opaque - Thermal

FibreC panels are fire resistant up to classification A1 per DIN, the panel is incombustible and has a temperature stability up to 350 degrees celsius without any coatings.

Thermally the assembly is intended to have insulation such as rockwool which is an all around waterproof, fireproof and soundproof type of B.A.T.T insulation inserted between the connection of masonry wall and and the vertical mounting post

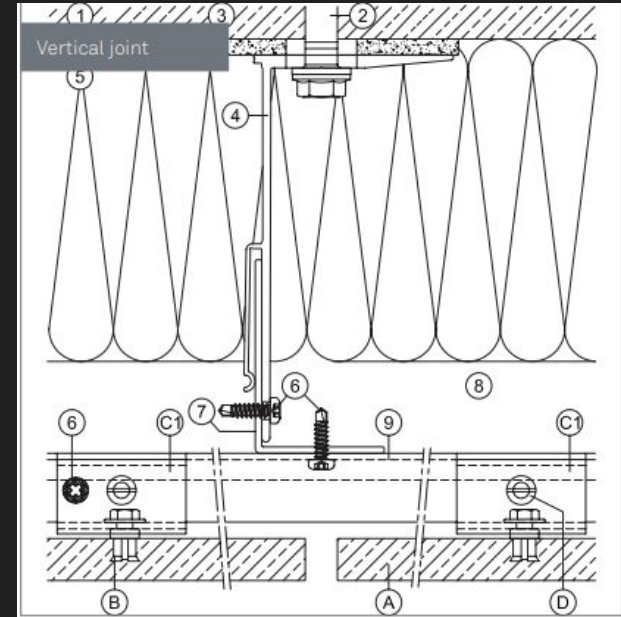

Opaque - Waterproofing

The manufacturer claims the panels are weather resistant, this would include rain, wind, sleet and snow etc. This is because the material is composed of a Glassfibre reinforced concrete, which includes “natural” and “raw” materials that create a “concrete-like” surface.

I’m presuming the material has some kind of natural additive so the panel stays fairly waterproof but if water were to get in, since there is a ventilation area it will evaporate. There are 8mm joints that are closed with bracket so there is no way water gets in but it provides that textured or extruded panel like look.

Curtain Wall - 1600UT (KAWNEER)

1600UT or Ultra Thermal is a curtain wall system manufactured by KAWNEER, This model is a development on the previous 1600 system in which the thermal resistance has been upgraded. 1600UT features high performance double and or triple glazed panels. This allows the panels to endure greater thermal performance without being susceptible to thermal fatigue.

All in all this is a high tech advanced curtain wall that focuses on maximum thermal performance for low to mid-rise applications.

Curtain Wall - Case Study

ProMedica Health and Wellness Center Sylvania, Ohio

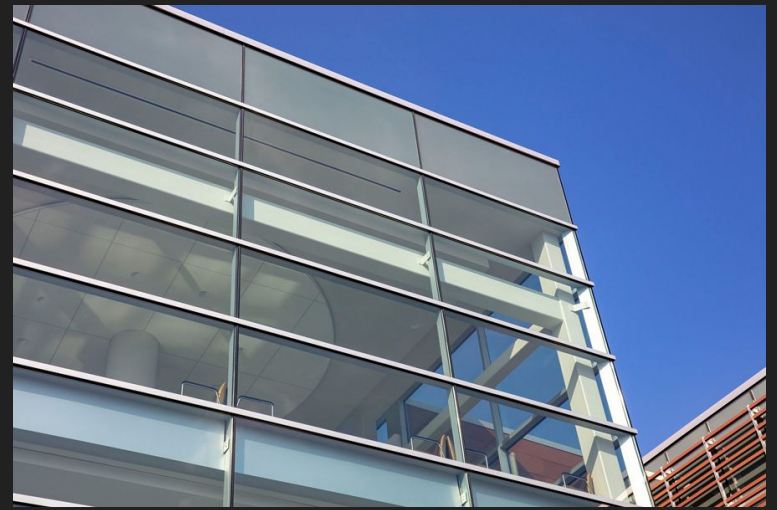



Curtain Wall - Structure

Curtain Walls are typically installed by mounting steel brackets that are bolted into concrete slabs, once these brackets are installed mullions proceed to go over them in the vertical connection, horizontal mullions are joined with the vertical mullion as well though the usage of brackets.

once the mullion itself is mounted and joined with the slab the glass segment is inserted inside the mullion or hung onto it, KAWNEER specifically allows the members to snap or click in place.

All joints are either bolted, screwed or clicked into place respectfully.

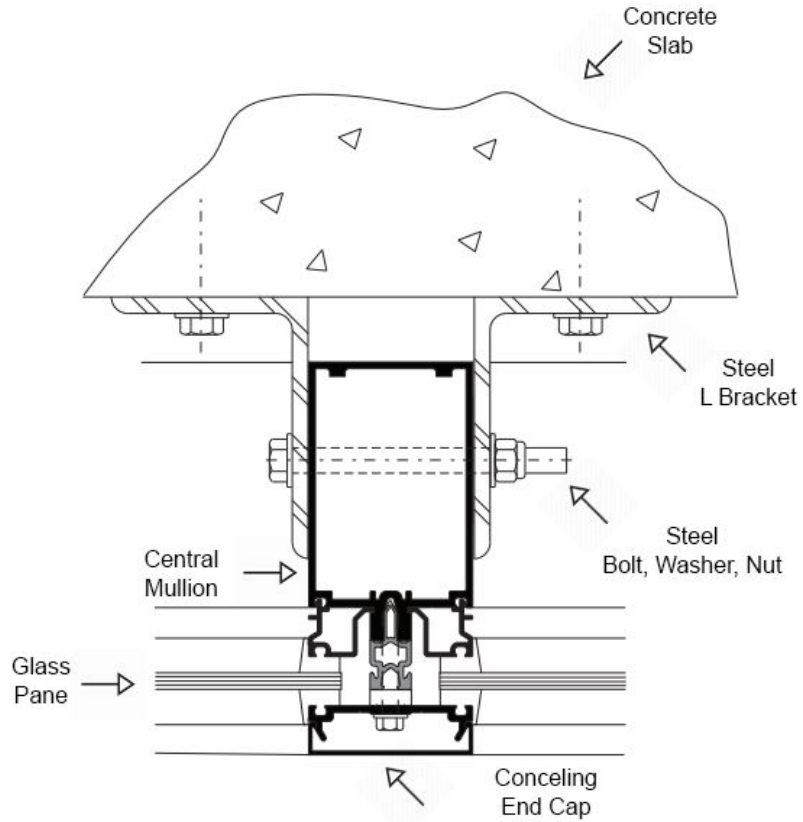

ANCHORING TO FLOOR SLAB

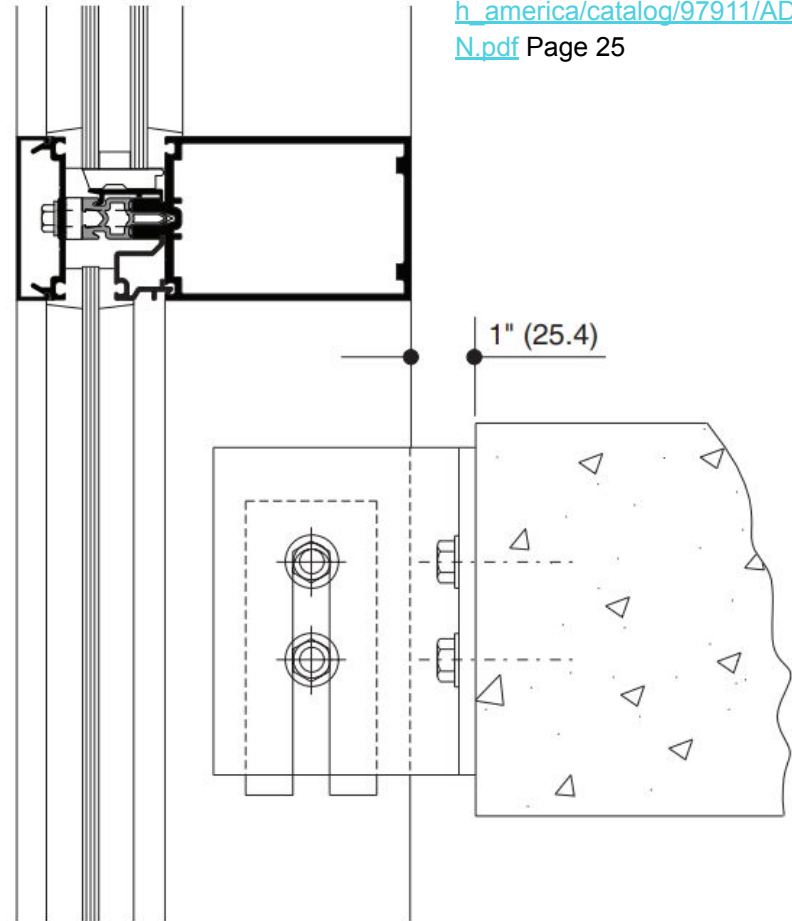

Curtain Wall - Thermal

KAWNEER focuses on the maximum energy efficiency possible by allowing the user to choose between a triple or a double paned system.

The thermal resistance is achieved by using an engineered polymer thermal separator and once again double and or triple glazed glass that provides insulating qualities.

Fiberglass pressure plates which are optional can also enhance condensation resistance and thermal performance.

https://www.kawneer.com/kawneer/north_america/catalog/product_flyers/17-2221_1600UT.pdf

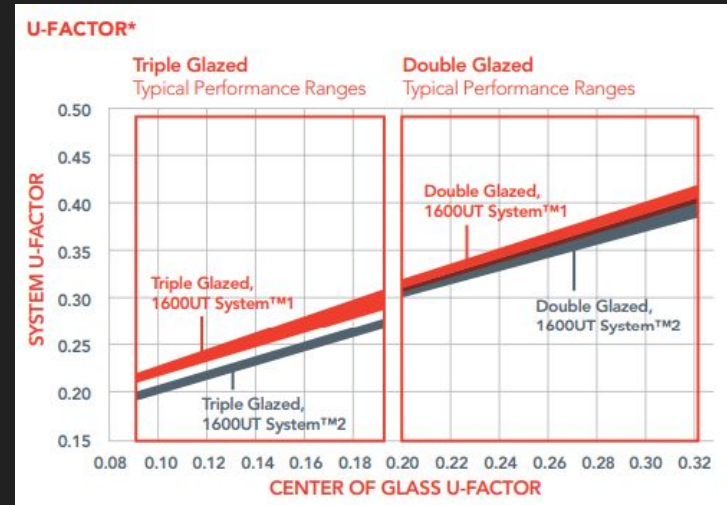
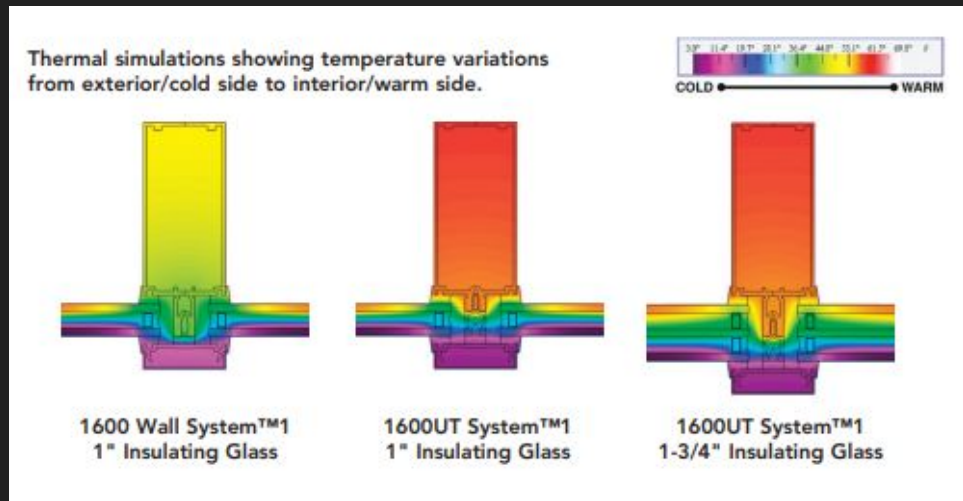

Curtain Wall - Waterproofing

Curtain walls are designed so water does not penetrate past them since they are one of the methods of exterior facade construction.

In KAWNEERS case the curtain wall has blocked off any possible method for water to enter in.

Water will hit the glass and drip straight off

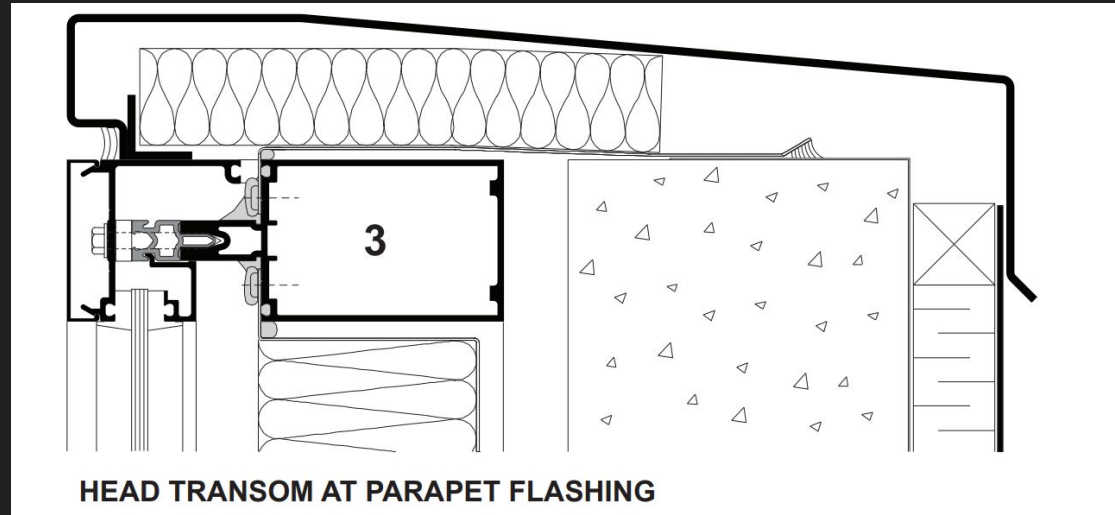

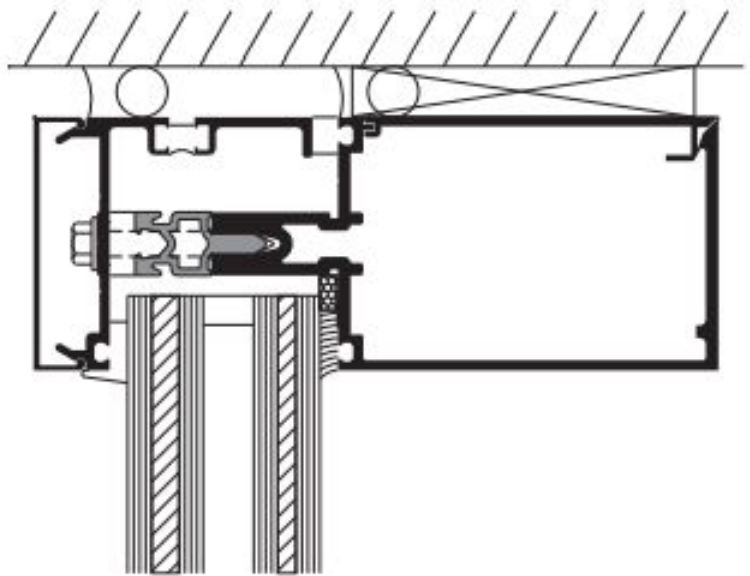

HEAD

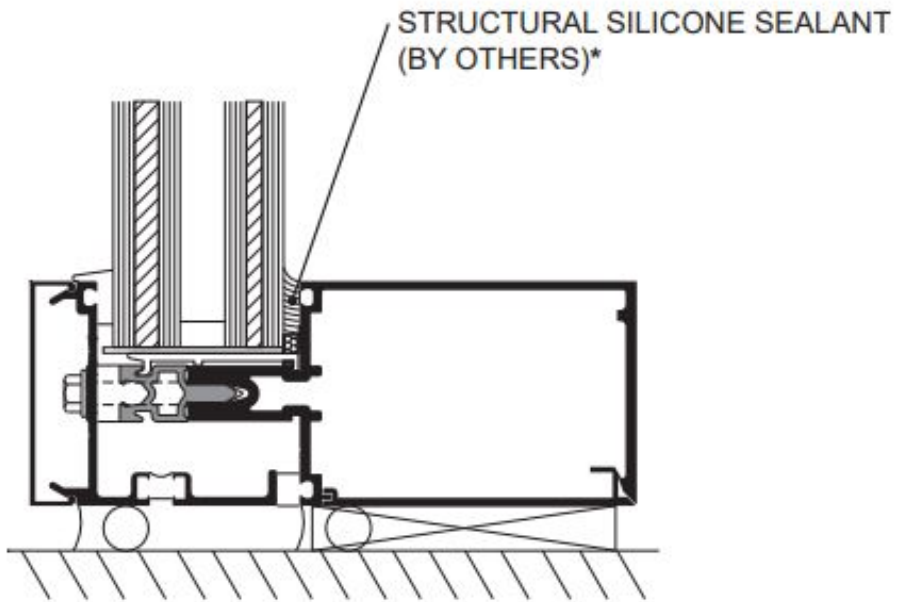

SILL

Curtain Wall Assembly

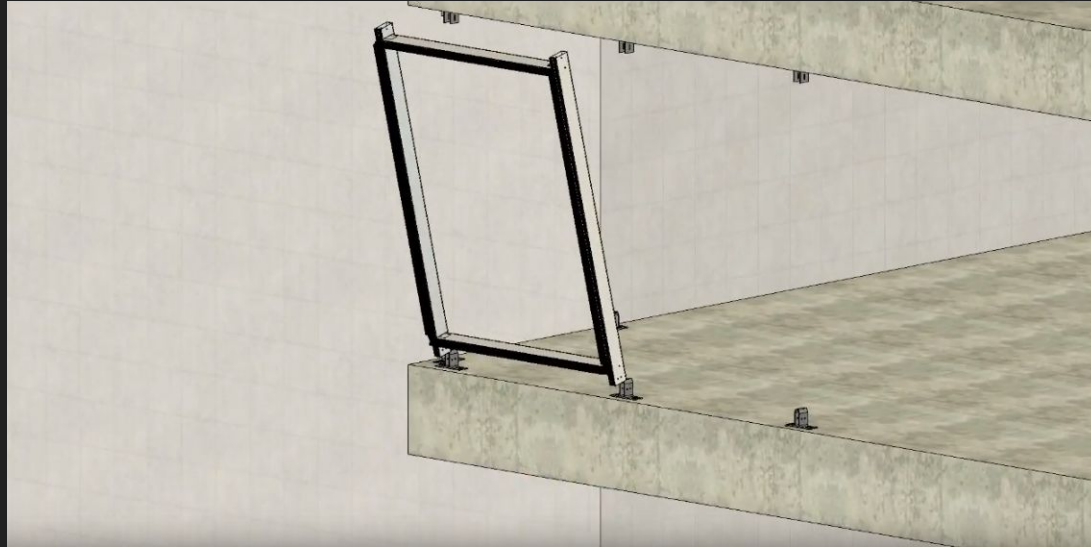

<https://www.youtube.com/watch?v=KxUXaThKxss>

Kawneer Video

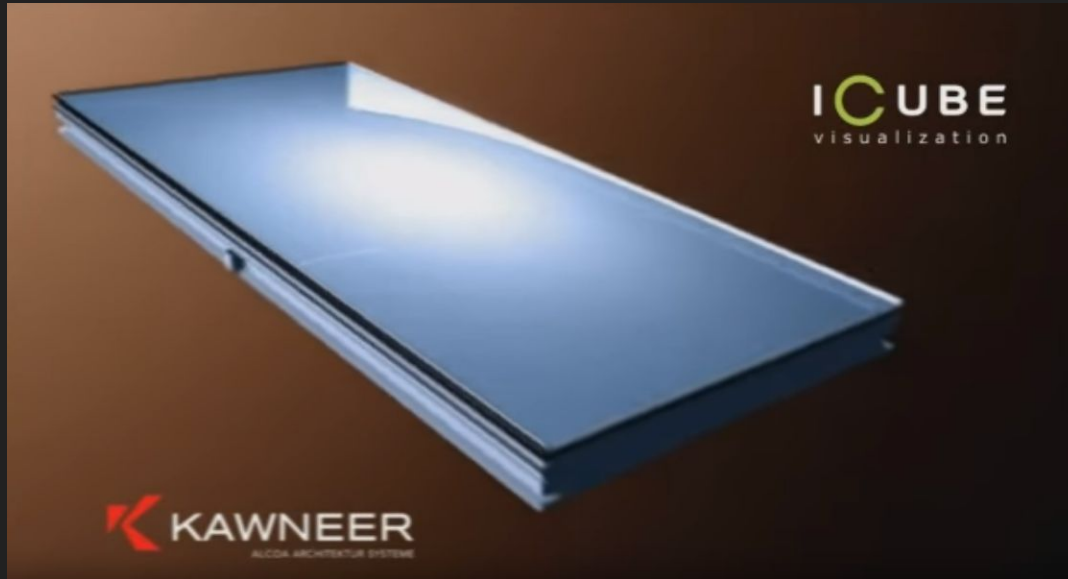

<https://www.youtube.com/watch?v=rq17EMz2xT0>

Sources

Opaque:

<https://www.rieder.cc/en/architecture/products/concrete-skin/>

<https://www.rieder.cc/wp-content/uploads/2017/07/fibreC-Technical-Manual.pdf>

https://www.archdaily.com/catalog/us/products/11637/concrete-skin-rieder-smart-elements?ad_source=neufert&ad_medium=gallery&ad_name=close-gallery

Curtain Wall:

<https://www.youtube.com/watch?v=KxUXaThKxss>

<https://www.youtube.com/watch?v=rq17EMz2xT0>

https://www.kawneer.com/kawneer/north_america/catalog/97911/ADMD080EN.pdf

https://www.kawneer.com/kawneer/north_america/catalog/product_flyers/17-2221_1600UT.pdf