

Opaque and Curtain Wall Systems

•••
By: Aileen Cepeda

Professor Kurasek
Spring 2020
Building Technology 3

Glass Curtain Wall System

MetroView® FG 501T

Window Wall

NEW PRODUCTS ▶

1620UT/1620UT SSG CURTAIN WALL SYSTEM

2500 UT UNITWALL® SYSTEM

METROVIEW® FG 501T WINDOW WALL

METROVIEW® FG 601T PG WINDOW WALL

AA@3200M THERMAL SLIDING DOORS

250T/350T/500T INSULPOUR® THERMAL ENTRANCES

AA@250/425 THERMAL ENTRANCES

INFRAME® INTERIOR FRAMING SYSTEM

GLASSVENT® UT (ULTRA THERMAL) WINDOWS

OPTIQ® AA@5450 SERIES WINDOWS

8225TLF THERMAL WINDOWS

MARKET SOLUTIONS ▶

HIGH-THERMAL PERFORMANCE PRODUCTS

HURRICANE RESISTANT PRODUCTS

BLAST MITIGATING PRODUCTS

ENTRANCES ▶

SWING

STOREFRONT FRAMING ▶

FIXED

SLIDING MALL

CURTAIN WALL ▶

TRADITIONAL

UNITIZED

WINDOW WALL

WINDOWS ▶

HUNG

HORIZONTAL SLIDING

CASEMENT

PROJECTED

TILT TURN

FIXED

HORIZONTAL RIBBON

KAWNEER WINDOW ACCESSORIES

NX WINDOW ACCESSORIES

TR WINDOW ACCESSORIES

MISCELLANEOUS

BALCONY DOORS ▶

SWING

SLIDING

SUN CONTROL PRODUCTS ▶

OVERHEAD GLAZING ▶

INTERIOR FRAMING ▶

VIEW PRODUCTS A TO Z ▶

MetroView® FG 501T Window Wall

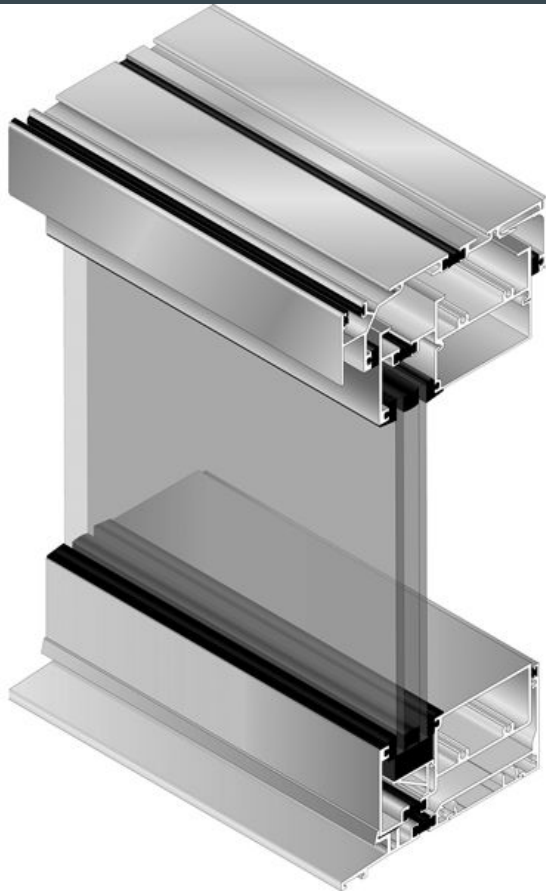

“Sleek, efficient and versatile. FG 501T Window Wall – the first in the MetroView® Window Wall series – packs the desired aesthetics of a curtain wall into a cost-efficient window wall system. Ideal for mid-rise commercial projects and sophisticated multi-family housing, MetroView® FG 501T Window Wall delivers the refined design features that are so popular in today’s urban and near-urban cityscapes.”

MetroView® FG 501T Window Wall offers the look of a true curtain wall with a slab-to-slab aluminum frame design. It has a 2-1/4" (57.2mm) sightline

For maximum square footage in interior spaces, FG 501T Window Wall is engineered for shallow horizontal inside glazing with the glass set to the front of the system. It is 5" (127mm) deep.

Screw spline fabrication and joinery means easy construction and low installation costs.

Air and water performance equal to many curtain walls and a range of aesthetic

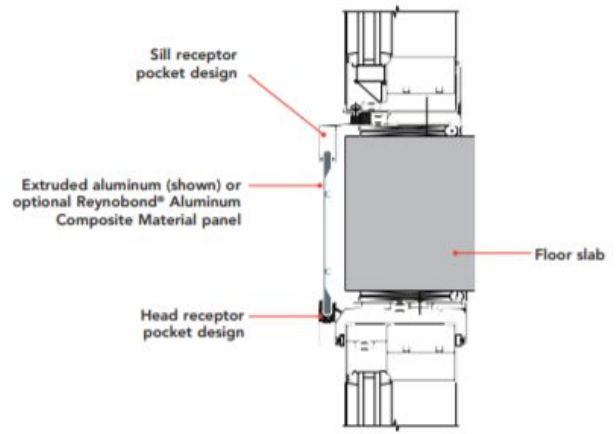
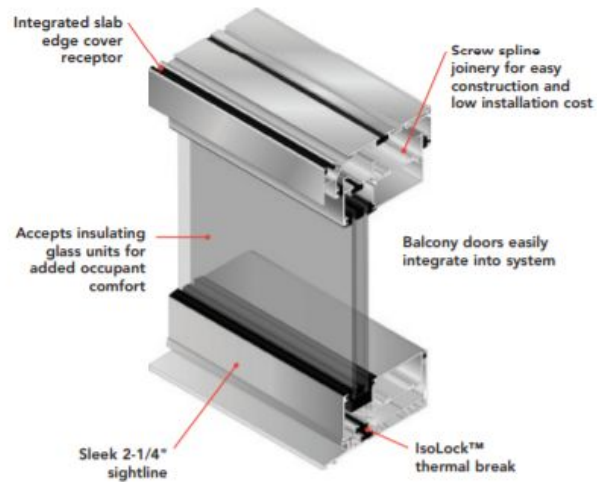



Head member assembly with 1" glass

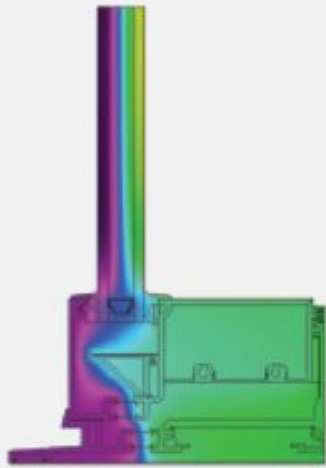

Sill member assembly with 1" glass

Color Legend

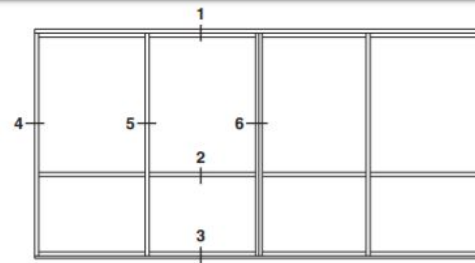

ELEVATION IS NUMBER KEYED TO DETAILS

INSIDE GLAZED

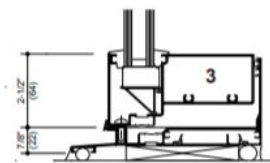
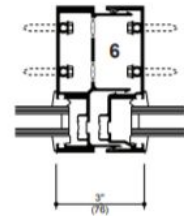
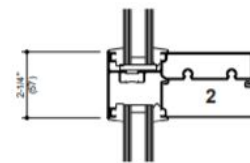
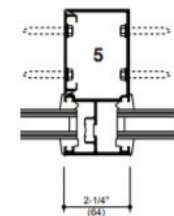
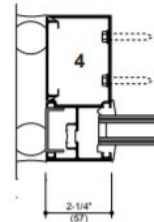
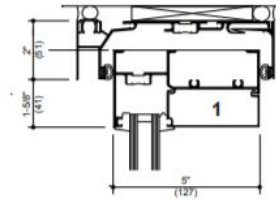

SLAB EDGE COVERS
(INSIDE GLAZED SHOWN, OUTSIDE GLAZED SIMILAR)

**STANDARD SILL RECEPTOR
WITH 7" SLAB COVER
(8" SLAB COVER SIMILAR)**

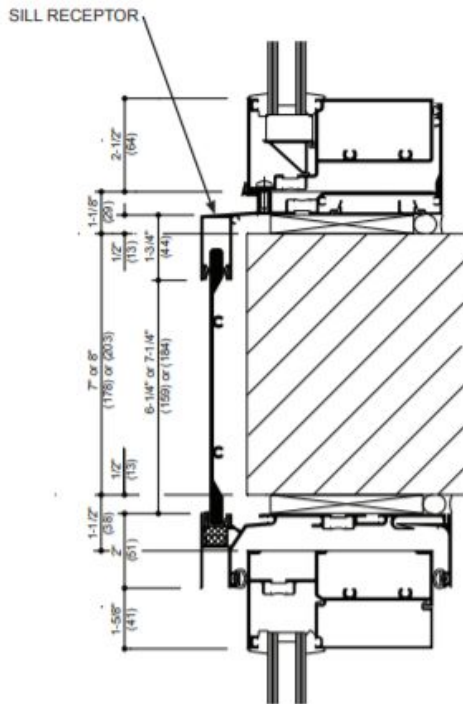

**HEAD RECEPTOR
(INTERIOR INSTALLED)**

**2-PIECE SILL RECEPTOR
WITH 7" SLAB COVER
(8" SLAB COVER SIMILAR)**

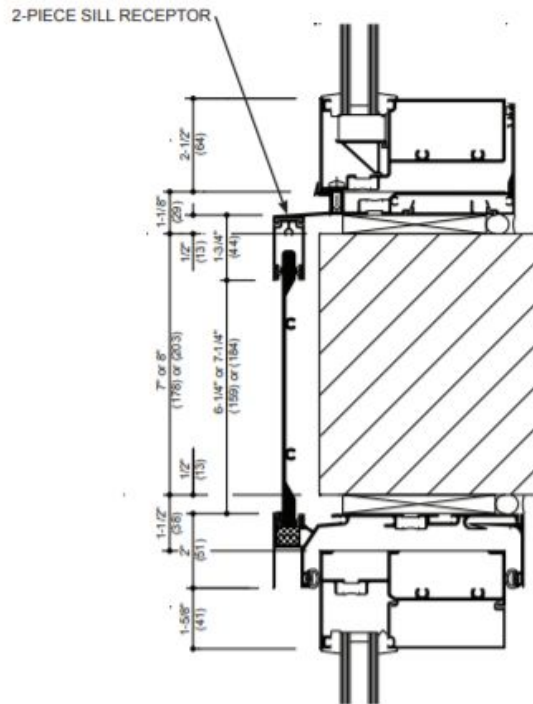

**HEAD RECEPTOR
(INTERIOR INSTALLED)**

Opaque Wall System

Fiber Cement Boards

Corrugated Fiber Cement Boards

Continuous Insulation Rain-Screen

Counter Tops

Cembrit Transparent (True) Fiber Reinforced Concrete Building Panels

Composite

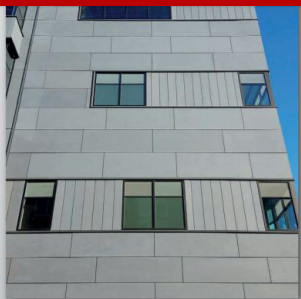

Cembrit Transparent (True) Fiber Reinforced Cement Composite Building Panels

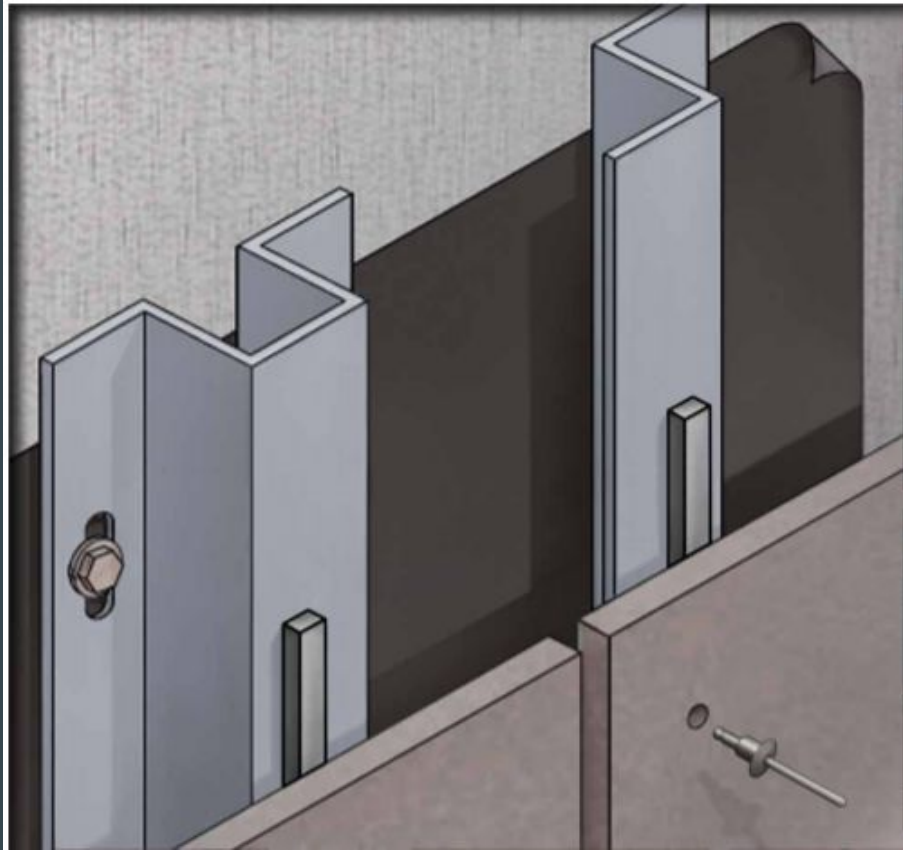

“Cembrit Transparent (formerly True) facade boards combine the textured nuances and natural characteristics of the base board with a long lasting performance of the transparent top coat. The color added to the fibre cement reveals and highlights the fibres and other raw materials that provide its strength and character. The extremely durable transparent coating then protects the board and ensures a smooth surface with a long service life.”

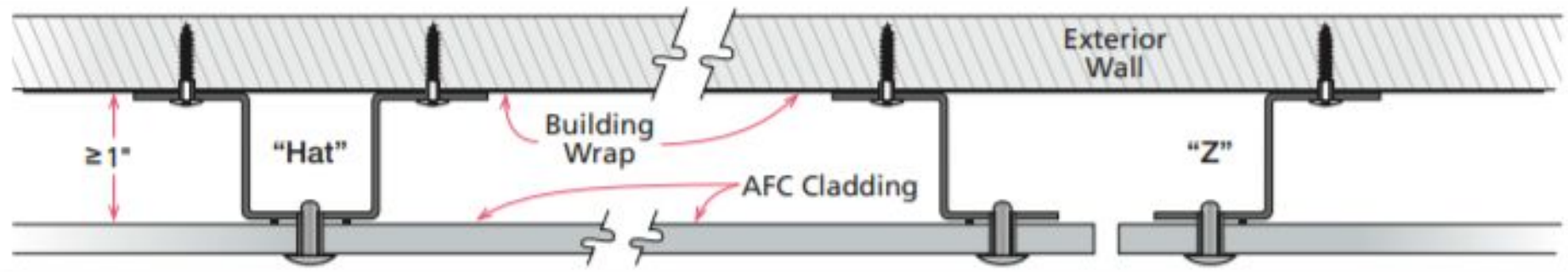

Typical Inside Corner – Plan View

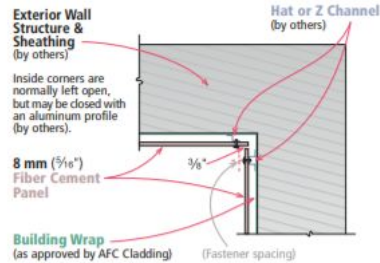

Typical Panel @ Window Head

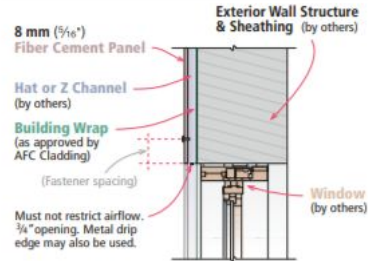

Typical Outside Corner – Plan View

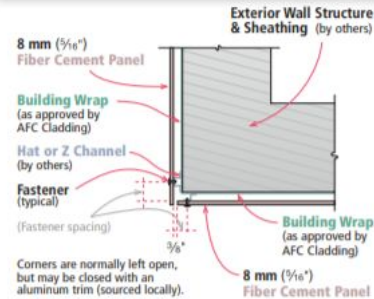

Typical Panel @ Door Head

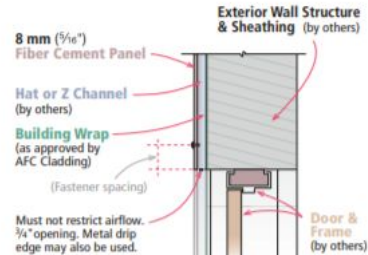

Typical Panel End @ Metal Panel

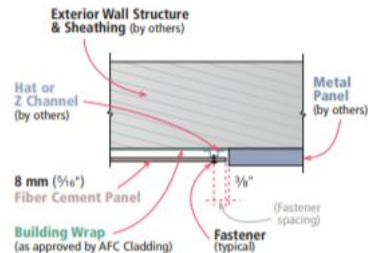

Typical Panel @ Parapet

