

PROYECTO:
Edificio Corporativo Centro Operativo
Anexo Pabellón de Amenidades
BBVA BANCOMER
Lago Alberto No. 320
Colonia Anáhuac, Delegación Miguel Alemán
C.P. 11500, México, D.F.

ARQUITECTO:
SOM
Skidmore, Owings & Merrill LLP
14 Wall Street, New York, NY 10005
(212) 298 9300
http://www.som.com

CONSULTOR:
IDEA ASOCIADOS de México
Av. San Jerónimo 240/2
Jardines del Pedregal
México 01900, D.F.

CONSULTOR:
AKF México
Higuera No. 35 P.B.
Coyacán, México DF 04000

CONSULTOR:
CTC Ingenieros
Av. José María Izazaga No. 89 5to Piso,
Colonia Centro, México DF

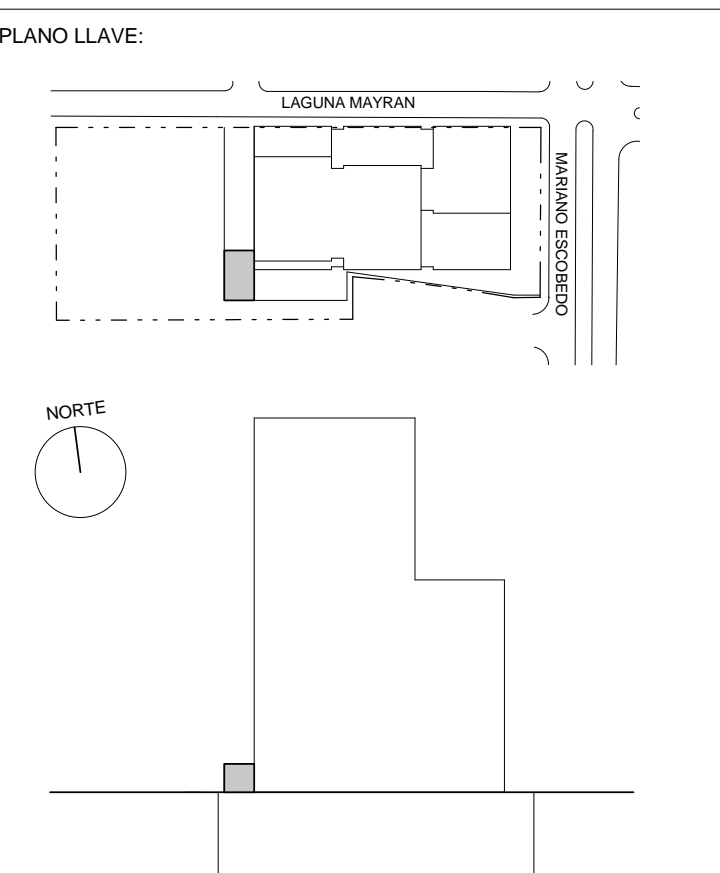

NOTAS:

MODIFICACIONES

No.	Description	Date

**NO PARA CONSTRUCCIÓN
NOT FOR CONSTRUCTION**

DIRECTOR RESPONSABLE DE OBRA
DR. HUGO GARCIA PEREZ D.R.O. : 0123

CORRESPONSABLE EN DISEÑO URBANO Y ARQUITECTONICO
DR. HUGO GARCIA PEREZ C.D.U. y A. : 0083

CORRESPONSABLE EN SEGUIMIENTO ESTRUCTURAL
ING. RAFAEL FORSBERG PRIETO CISE : 0117

CORRESPONSABLE EN INSTALACIONES
ING. ANDRÉS GUILLERMO FORBES TEPICAN CA : 0011

EMITIDO PARA:

**DISEÑO ESQUEMATICO
SCHEMATIC DESIGN**

PLANO:

**PLANTA DE PLAFONES
NIVEL 1
REFLECTED CEILING PLAN
LEVEL 1**

Copyright © 2012, Skidmore, Owings & Merrill LLP

A-402

DRUJO: Author SOM LEGAL REPRESENTATIVE PETER JAMES MAGILL

REVISOR: Checker

ESCALA: 1 : 50 FECHA: 10 DICIEMBRE, 2012

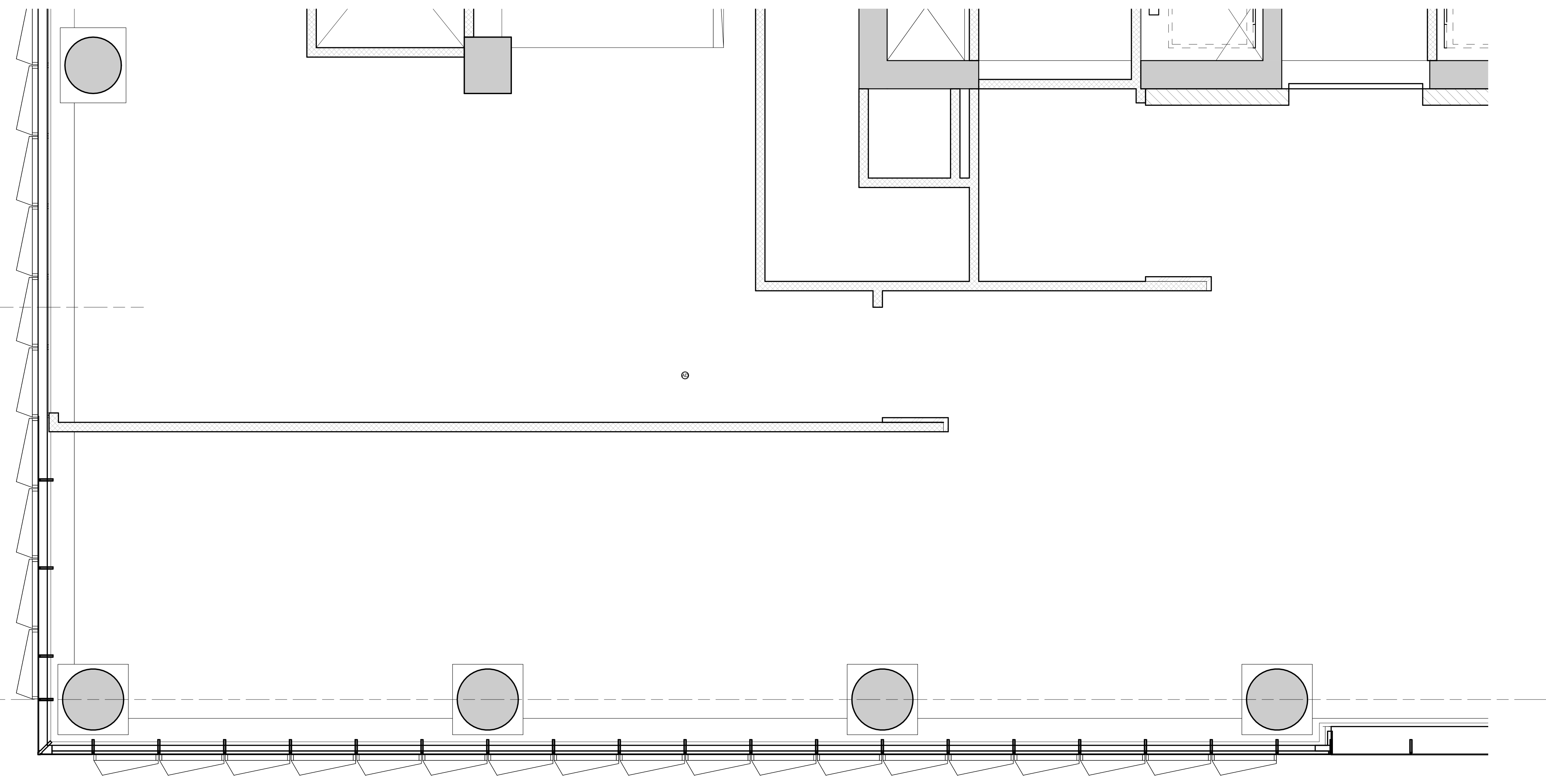
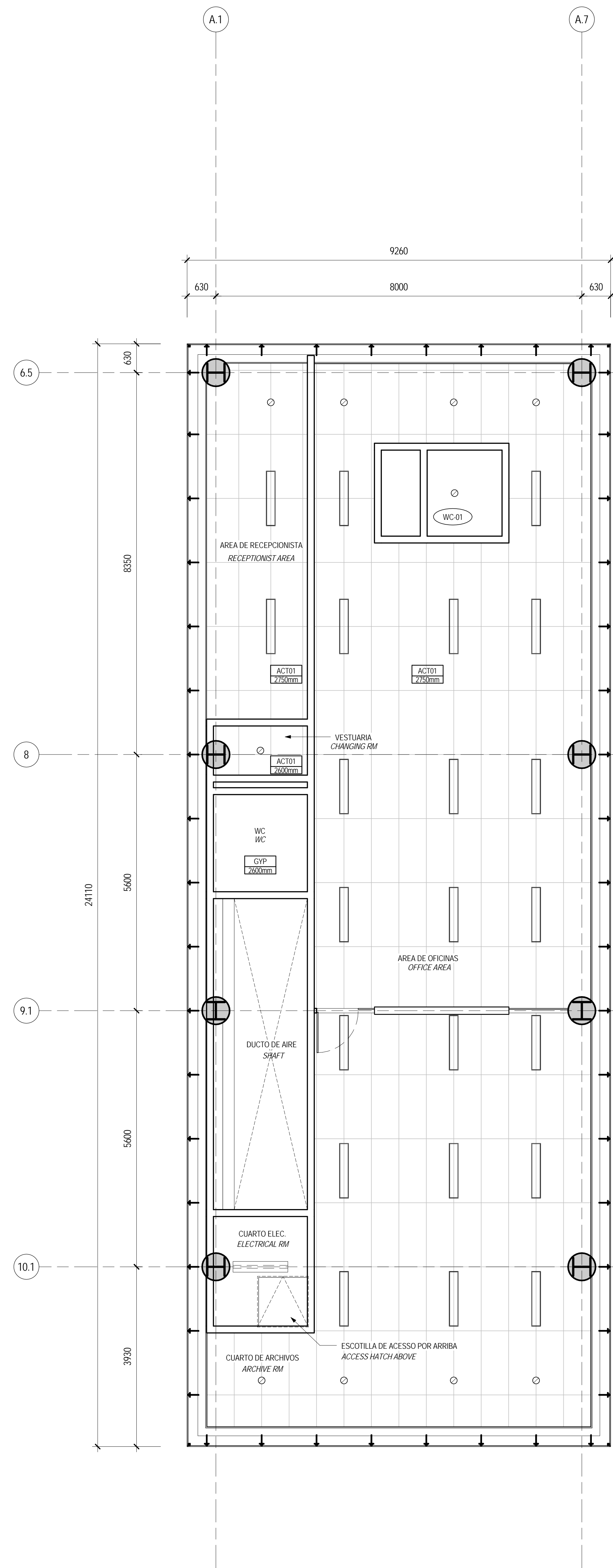

**1 PLANTA DE CIELORASO NIVEL 1
REFLECTED CEILING PLAN LEVEL 1**
1 : 50

LEYENDA DE PLANTA DE CIELORASO
REFLECTED CEILING PLAN LEGEND

	TECHO DE YESO GYP. CEILING		LAMPARA FLUORESCENTE MONTADA EN TECHO O LAMPARA INDUSTRIAL CEILING MOUNTED FLUORESCENT 5'x9' OR INDUSTRIAL FIXTURE
	ADORNADO DEL TECHO ACUSTICAS ACOUSTICAL CEILING TILE		LAMPARA FLUORESCENTE COMPACTA DE LUZ EMBITIDA DE 20 WATT DE DIAMETRO 20 W COMPACT FLUORESCENT COMPACT FLUORESCENT FIXTURE
	RECESADO DE LUZ RECESSED LIGHT FIXTURE		LAMPARA FLUORESCENTE COMPACTA DE LUZ EMBITIDA DE 20 WATT DE DIAMETRO EN OPERACION DE EMERGENCIA 20 W COMPACT FLUORESCENT COMPACT FLUORESCENT FIXTURE IN EMERGENCY MODE
	TRIL LAMPARA FLUORESCENTE FLUORESCENT TRACK FIXTURE		LETRODO DE SAL MONTADO EN TECHO CEILING MOUNTED EXIT SIGN
	LUZ EMERGENCIA EMERGENCY LIGHT FIXTURE		LETRODO DE SAL MONTADO EN LA PARED WALL MOUNTED EXIT SIGN
	LAMPARA INDUSTRIAL CERRADA Y SELLADA MONTADA EN TECHO INDUSTRIAL AND GASKETED INDUSTRIAL FIXTURE, CEILING MOUNTED		ROTORRONES E EMERGENCIA CARRERA EMERGENCY EXIT SIGN
	LAMPARA INDUSTRIAL CERRADA Y SELLADA MONTADA EN TECHO EN OPERACION DE EMERGENCIA INDUSTRIAL AND GASKETED INDUSTRIAL FIXTURE, CEILING MOUNTED IN EMERGENCY MODE		CAMERA DE SEGURIDAD SECURITY CAMERA

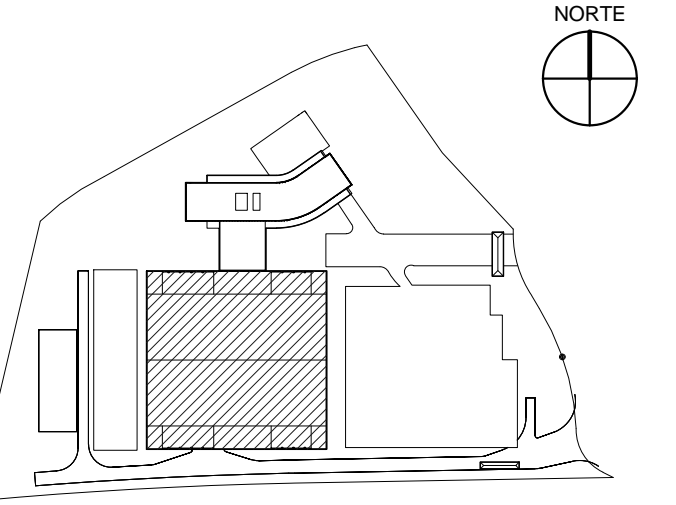

- NOTAS:**
1. PARA UNA COMPLETA DESCRIPCIÓN DE CADA MATERIAL COORDINAR CON SERIE C-113 FOR A COMPLETE DESCRIPTION OF THE MATERIALS COORDINATE WITH SERIES C-113
 2. COORDINAR CON SERIE CC-AL110 - PLANTAS DE ALBAÑERÍA COORDINATE WITH SERIES CC-AL110 - CONSTRUCTION PLANS
 3. COORDINAR CON SERIE CC-AC110 - PLANTAS DE ACABADOS COORDINATE WITH SERIES CC-AC110 - FINISHES PLANS
 4. COORDINAR CON SERIE CC-A300 - PLANTAS NUCLEOS DE ELEVADORES COORDINATE WITH SERIES CC-A300 - ENLARGED ELEVATOR CORE PLANS
 5. COORDINAR CON SERIE CC-A510 - DETALLES DE FACHADAS COORDINATE WITH SERIES CC-A510 - BUILDING ENCLOSURE
 6. COORDINAR CON SERIE CC-A600 - ELEVACIONES INTERIORES COORDINATE WITH SERIES CC-A600 - INTERIOR ELEVATIONS
 7. COORDINAR CON SERIE CC-A660 - TIPOS DE PUERTAS COORDINATE WITH SERIES CC-A660 - DOORS SCHEDULES
 8. COORDINAR CON SERIE PMA700 - TIPOS DE MURDO COORDINATE WITH SERIES PMA700 - PARTITIONS WALL TYPES
 9. COORDINAR CON PROYECTO ESTRUCTURAL COORDINATE WITH STRUCTURAL PROJECT
 10. COORDINAR CON PROYECTO DE INSTALACIONES COORDINATE WITH MEP PROJECT
 11. COORDINAR CON PROYECTO DE INSTALACIONES COORDINATE WITH MEP PROJECT

MODIFICACIONES:

No.	Descripción	Fecha
1	DOCUMENTOS DE CONSTRUCCIÓN	20 JULIO 2012
2	ADENDA 1	14 SEPT. 2012
3	ADENDA 2	22 OCTUBRE 2012

PROPIETARIO:
APLICA TECNOLOGIA AVANZADA, S. A. DE C. V.

REPRESENTANTE LEGAL DE APLICACION:
TECNOLOGIA AVANZADA, S. A. DE C. V.
ING. RODOLFO MEDINA ROSAS

DIRECTOR DEL PROYECTO
ARG. JAIIME M. LEMUS DELGADO

PERITO RESPONSABLE DE OBRA PRIVADA No. INE71907
DR. HUGO GARCIA PEREZ

EMITIDO PARA:
PAQUETE DE CENTRO DE COMPUTO

DATA HALL PACKAGE

PLANO:

**PLANTA DE PLAFONES NIVEL S1
REFLECTIVE CEILING PLAN LEVEL S1**

Copyright © 2012, Skidmore, Owings & Merrill LLP

CC-A400

DRUJO:	YR	SOM LEGAL REPRESENTATIVE PETER JAMES MAGILL
REVISOR:	SP	
ESCALA:	As indicated	FECHA: 20 JULIO 2012

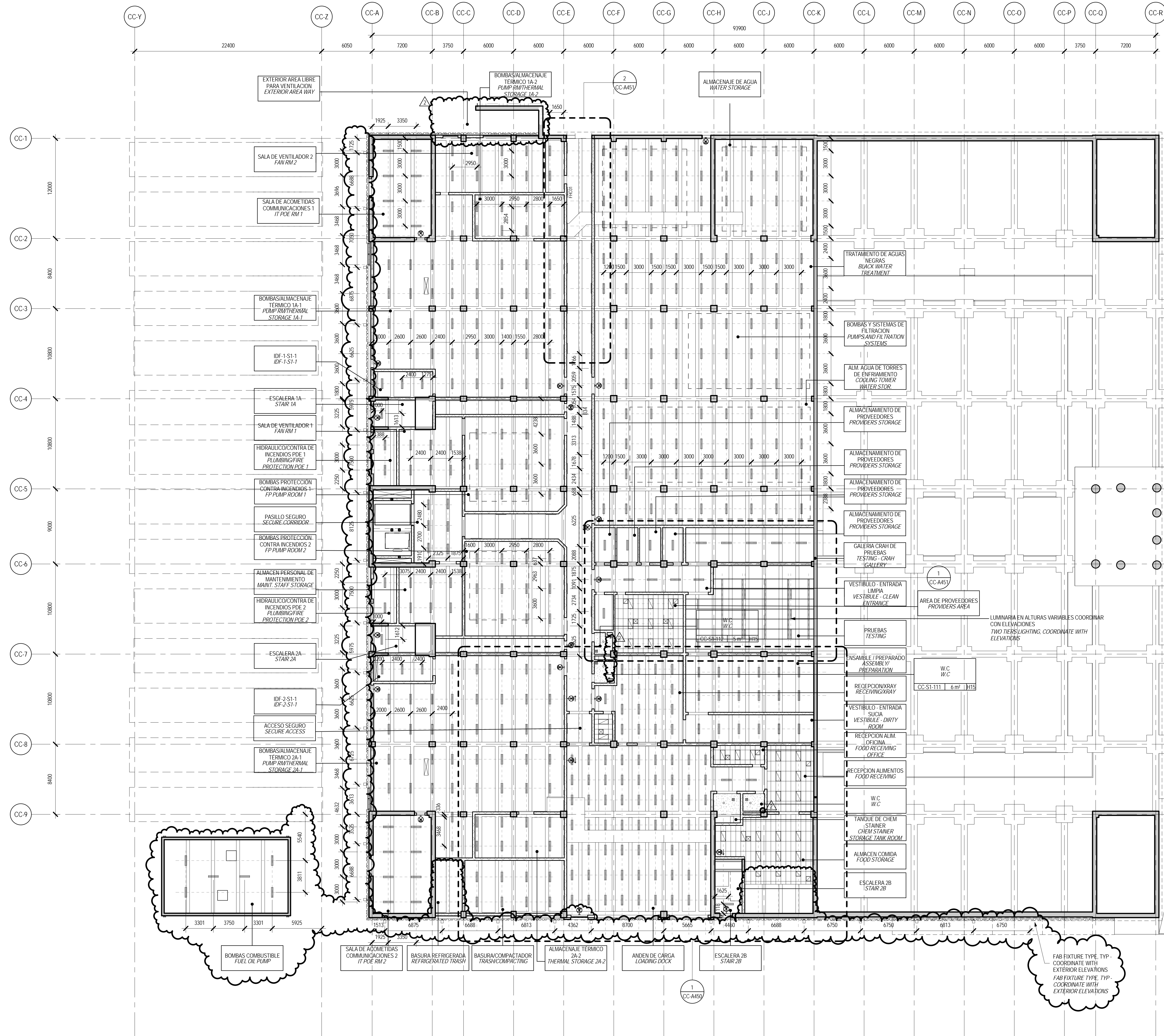

NOTA: REFERIR A DIBUJOS ELECTRICOS PARA TIPOS DE ACCESORIOS
NOTE: REFER TO ELECTRICAL DRAWINGS FOR FIXTURE TYPES

**1 PLANTA DE PLAFONES NIVEL S1
REFLECTED CEILING PLAN LEVEL S1**
1:200

**SIMBOLOGIA DE PLAFONES
REFLECTED CEILING PLAN LEGEND**

	TECHO DE YESO GYP. CEILING		SEÑALIZACION DE SALIDA MONTAJE EN TECHO CEILING MOUNTED EXIT SIGN
	PLAFON MODULAR ACUSTICO ACOUSTICAL CEILING TILE		SEÑALIZACION DE SALIDA MONTAJE EN MURO WALL MOUNTED EXIT SIGN
	LUMINARIA LINEAL DE LED SUSPENDIDA, MONTAJE EN TECHO LINEAR LED SUSPENDED, CEILING MOUNTED		ROCADORES EMPOTRADOS RECESSED SPRINKLER HEAD
	LUMINARIA TIPO GABINETE MODULAR MODULAR LAMP		
	LAMPARA INDUSTRIAL CERRADA Y SELLADA, MONTAJE EN TECHO ENCLOSED AND GASKETED INDUSTRIAL FIXTURE, CEILING MOUNTED		
	LUMINARIA FLUORESCENTE COMPACTA DE LUZ EMBUITIDA DE 200 MM DE DIAMETRO 200 MM DIAMETER DOWNLIGHT COMPACT FLUORESCENT FIXTURE		

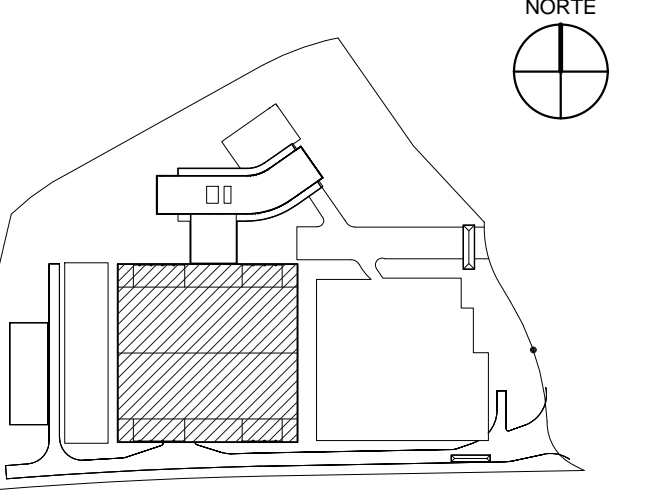

NOTAS:

1. PARA UNA COMPLETA DESCRIPCIÓN DE CADA MATERIAL COORDINAR CON SERIE C-011 FOR A COMPLETE DESCRIPTION OF THE MATERIALS COORDINATE WITH SERIES C-011
2. COORDINAR CON SERIE CC-A110: PLANTAS DE ALUMBRERA COORDINATE WITH SERIES CC-A110: CONSTRUCTION PLANS
3. COORDINAR CON SERIE CC-A110: PLANTAS DE ACABADOS COORDINATE WITH SERIES CC-A110: FINISHES PLANS
4. COORDINAR CON SERIE CC-A300: PLANTAS NUCLEOS DE ELEVADORES COORDINATE WITH SERIES CC-A300: ENLARGED ELEVATOR CORE PLANS
5. COORDINAR CON SERIE CC-A510: DETALLES DE FACHADAS COORDINATE WITH SERIES CC-A510: BUILDING ENCLOSURE
6. COORDINAR CON SERIE CC-A600: ELEVACIONES INTERIORES COORDINATE WITH SERIES CC-A600: INTERIOR ELEVATIONS
7. COORDINAR CON SERIE CC-A660: TIPOS DE PUERTAS COORDINATE WITH SERIES CC-A660: DOORS SCHEDULES
8. COORDINAR CON SERIE P-A110: TIPOS DE MURO COORDINATE WITH SERIES P-A110: PARTITIONS WALL TYPES
9. COORDINAR CON PROYECTO ESTRUCTURAL COORDINATE WITH STRUCTURAL PROJECT
10. COORDINAR CON PROYECTO DE INSTALACIONES COORDINATE WITH MEP PROJECT
11. COORDINAR CON PROYECTO DE INSTALACIONES COORDINATE WITH MEP PROJECT

MODIFICACIONES:

No.	Descripción	Fecha
1	DOCUMENTOS DE CONSTRUCCIÓN	20 JULIO 2012
2	ADENDA 1	14 SEPT. 2012
3	ADENDA 2	22 OCTUBRE 2012

PROPIETARIO
APLICA TECNOLOGIA AVANZADA, S.A. DE C.V.

REPRESENTANTE LEGAL DE APLICACION
TECNOLOGIA AVANZADA, S.A. DE C.V.
ING. RODOLFO MEDINA-ROOS

DIRECTOR DEL PROYECTO
ARG. JAMES M. LENIUS DELGADO

PERTO RESPONSABLE DE OBRA PRIVADA No. INE71907
DR. HUGO GARCIA PEREZ

EMITIDO PARA:
PAQUETE DE CENTRO DE COMPUTO
DATA HALL PACKAGE

PLANO:

PLANTA PLAFON AMPLIADA ANDEN DE CARGA
ENLARGED REFLECTED CLG. PLAN: LOADING DOCK

Copyright © 2012, Skidmore, Owings & Merrill LLP

CC-A450

DRUJO:	YR	SOM LEGAL REPRESENTATIVE PETER JAMES MAGILL
REVISO:	SP	
ESCALA:	1 : 50	FECHA: 20 JULIO 2012

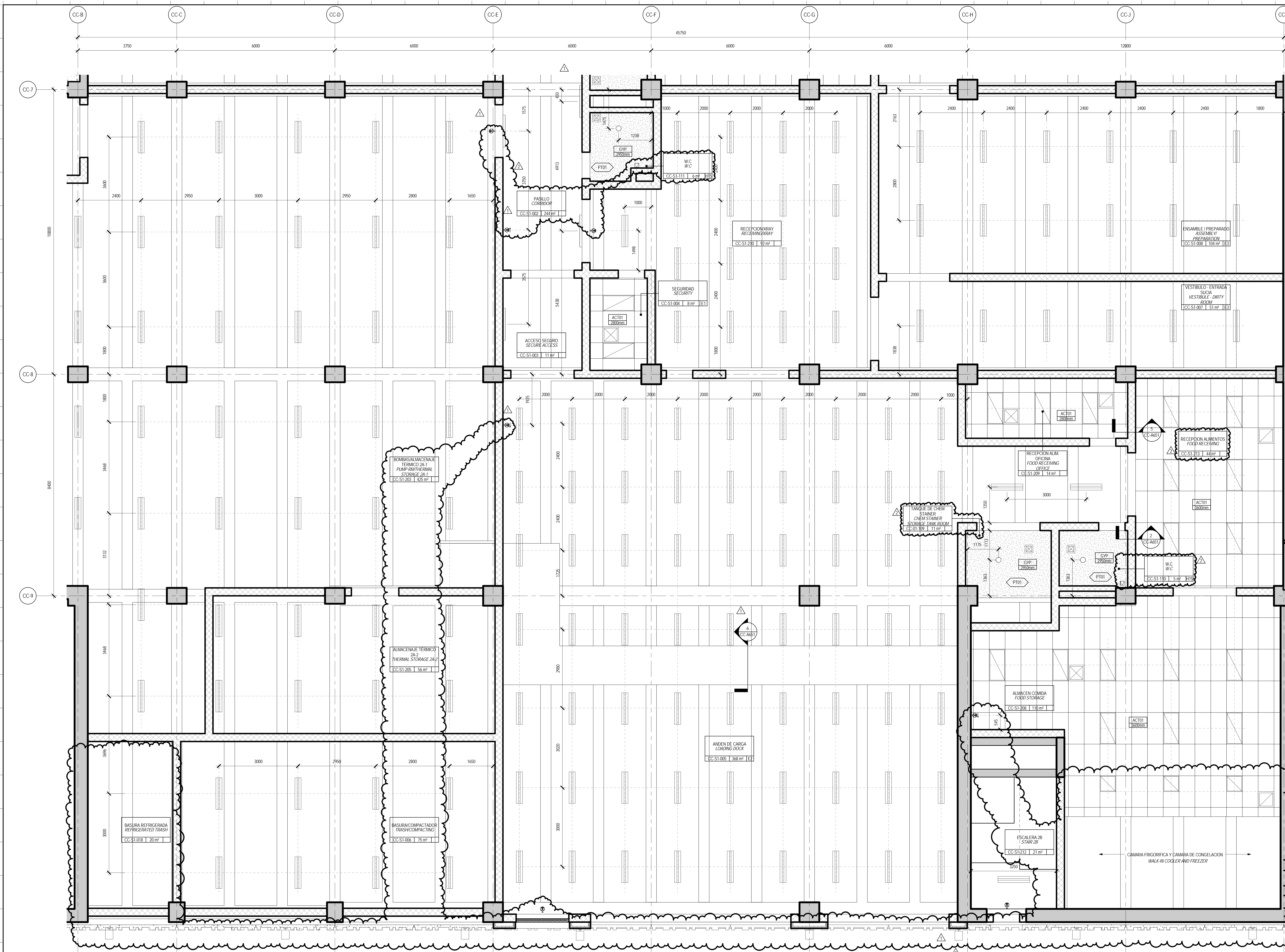

1 PLANTA PLAFON AMPLIADA ANDEN DE CARGA
ENLARGED REFLECTED CLG. PLAN: LOADING DOCK
1:50

SINBOLOGIA DE PLAFONES
REFLECTED CEILING PLAN LEGEND

	TECHO DE YESO GYP. CEILING		SEÑALIZACION DE SALIDA MONTAJE EN TECHO CEILING MOUNTED EXIT SIGN
	PLAFON MODULAR ACUSTICO ACOUSTICAL CEILING TILE		SEÑALIZACION DE SALIDA MONTAJE EN MURO WALL MOUNTED EXIT SIGN
	LUMINARIA LINEAL DE LED SUSPENDIDA, MONTAJE EN TECHO LINEAR LED SUSPENDED CEILING MOUNTED		ROCIADORES EMPOTRADOS RECESSED SPRINKLER HEAD
	LUMINARIA TIPO GABINETE MODULAR MODULAR LAMP		
	LAMPARA INDUSTRIAL CERRADA Y SELADA, MONTAJE EN TECHO ENCLOSED AND GASKETED INDUSTRIAL FIXTURE, CEILING MOUNTED		
	LUMINARIA FLUORESCENTE COMPACTA DE LUZ EMBUDIDA DE 200 MM DE DIAMETRO 200 MM DIAMETER DOWNLIGHT COMPACT FLUORESCENT FIXTURE		

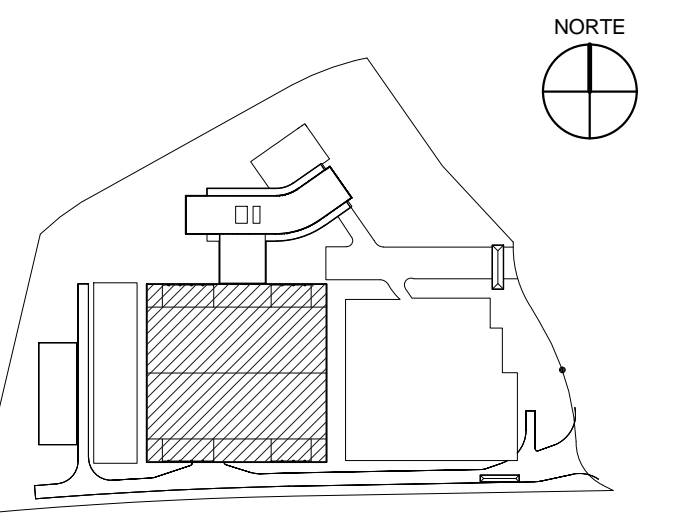

- NOTAS:**
1. PARA UNA COMPLETA DESCRIPCIÓN DE CADA MATERIAL COORDINAR CON SERIE G-013 FOR A COMPLETE DESCRIPTION OF THE MATERIALS COORDINATE WITH SERIES G-013
 2. COORDINAR CON SERIE CC-AL110 - PLANTAS DE ALBAÑERÍA COORDINATE WITH SERIES CC-AL110 - CONSTRUCTION PLANS
 3. COORDINAR CON SERIE CC-AC110 - PLANTAS DE ACABADOS COORDINATE WITH SERIES CC-AC110 - FINISHES PLANS
 4. COORDINAR CON SERIE CC-AS00 - PLANTAS NÚCLEOS DE ELEVADORES COORDINATE WITH SERIES CC-AS00 - ENLARGED ELEVATOR CORE PLANS
 5. COORDINAR CON SERIE CC-AS10 - DETALLES DE FACHADAS COORDINATE WITH SERIES CC-AS10 - BUILDING ENCLOSURE
 6. COORDINAR CON SERIE CC-AG00 - ELEVACIONES INTERIORES COORDINATE WITH SERIES CC-AG00 - INTERIOR ELEVATIONS
 7. COORDINAR CON SERIE CC-AD00 - TIPOS DE PUERTAS COORDINATE WITH SERIES CC-AD00 - DOORS SCHEDULES
 8. COORDINAR CON SERIE CC-AP00 - TIPOS DE MURO COORDINATE WITH SERIES CC-AP00 - PARTITIONS WALL TYPES
 9. COORDINAR CON PROYECTO ESTRUCTURAL COORDINATE WITH STRUCTURAL PROJECT
 10. COORDINAR CON PROYECTO DE INSTALACIONES COORDINATE WITH MEP PROJECT
 11. COORDINAR CON PROYECTO DE INSTALACIONES COORDINATE WITH MEP PROJECT

MODIFICACIONES:

No.	Descripción	Fecha
1	DOCUMENTOS DE CONSTRUCCIÓN	20 JULIO 2012
2	ADENDA 1	14 SEPT. 2012
3	ADENDA 2	22 OCTUBRE 2012

PROPIETARIO:
APLICA TECNOLOGIA AVANZADA, S. A. DE C. V.

REPRESENTANTE LEGAL DE APLICACION:
TECNOLOGIA AVANZADA, S. A. DE C. V.
ING. RODOLFO MEDINA ROSAS

DIRECTOR DEL PROYECTO:
ARG. JAI ME M. LEMUS DELGADO

PERTO RESPONSABLE DE OBRA PRIVADA No. 062/1007
DR. HUGO GARCIA PEREZ

EMITIDO PARA:
PAQUETE DE CENTRO DE COMPUTO
DATA HALL PACKAGE

PLANO:
PLANTA PLAFON AMPLIADA AREA DE PRUEBAS, PROVEDORES Y RAMPAS ENLARGED REFLECTED CLG. PLAN: RAMP, TESTING AND PROVIDERS ZONE

Copyright © 2012, Skidmore, Owings & Merrill LLP

CC-A451

DEBUIO:	YR	SOM LEGAL REPRESENTATIVE PETER JAMES MAGILL
REVISIO:	SP	
ESCALA:	1 : 50	FECHA: 20 JULIO 2012

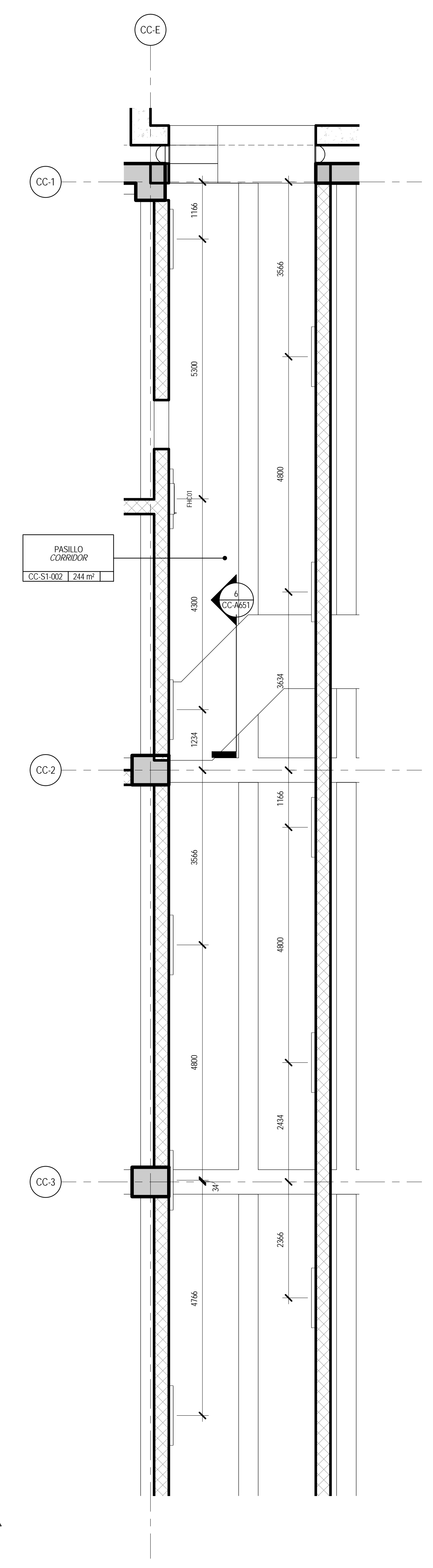

2 PLANTA PLAFON AMPLIADA ZONA DE RAMPAS ENLARGED REFLECTED CLG. PLAN : RAMP ZONE
T : 50

SIMBOLOGIA DE PLAFONES REFLECTED CEILING PLAN LEGEND

	TECHO DE YESO GYP CEILING		SEÑALIZACION DE SALIDA MONTAJE EN TECHO CEILING MOUNTED EXIT SIGN
	PLAFON MODULAR ACUSTICO ACOUSTICAL CEILING TILE		SEÑALIZACION DE SALIDA MONTAJE EN MURO WALL MOUNTED EXIT SIGN
	LUMINARIA LINEAL DE LED SUSPENDIDA, MONTAJE EN TECHO LINEAR LED SUSPENDED, CEILING MOUNTED		ROCIADORES EMPOTRADOS RECESSED SPRINKLER HEAD
	LUMINARIA TIPO GABINETE MODULAR MODULAR LAMP		
	LAMPARA INDUSTRIAL CERRADA Y SELADA, MONTAJE EN TECHO ENCLOSED AND GASKETED INDUSTRIAL FIXTURE, CEILING MOUNTED		
	LUMINARIA FLUORESCENTE COMPACTA DE LUZ EMBUIDA DE 200 MM DE DIAMETRO 200MM DIAMETER DOWNLIGHT COMPACT FLUORESCENT FIXTURE		

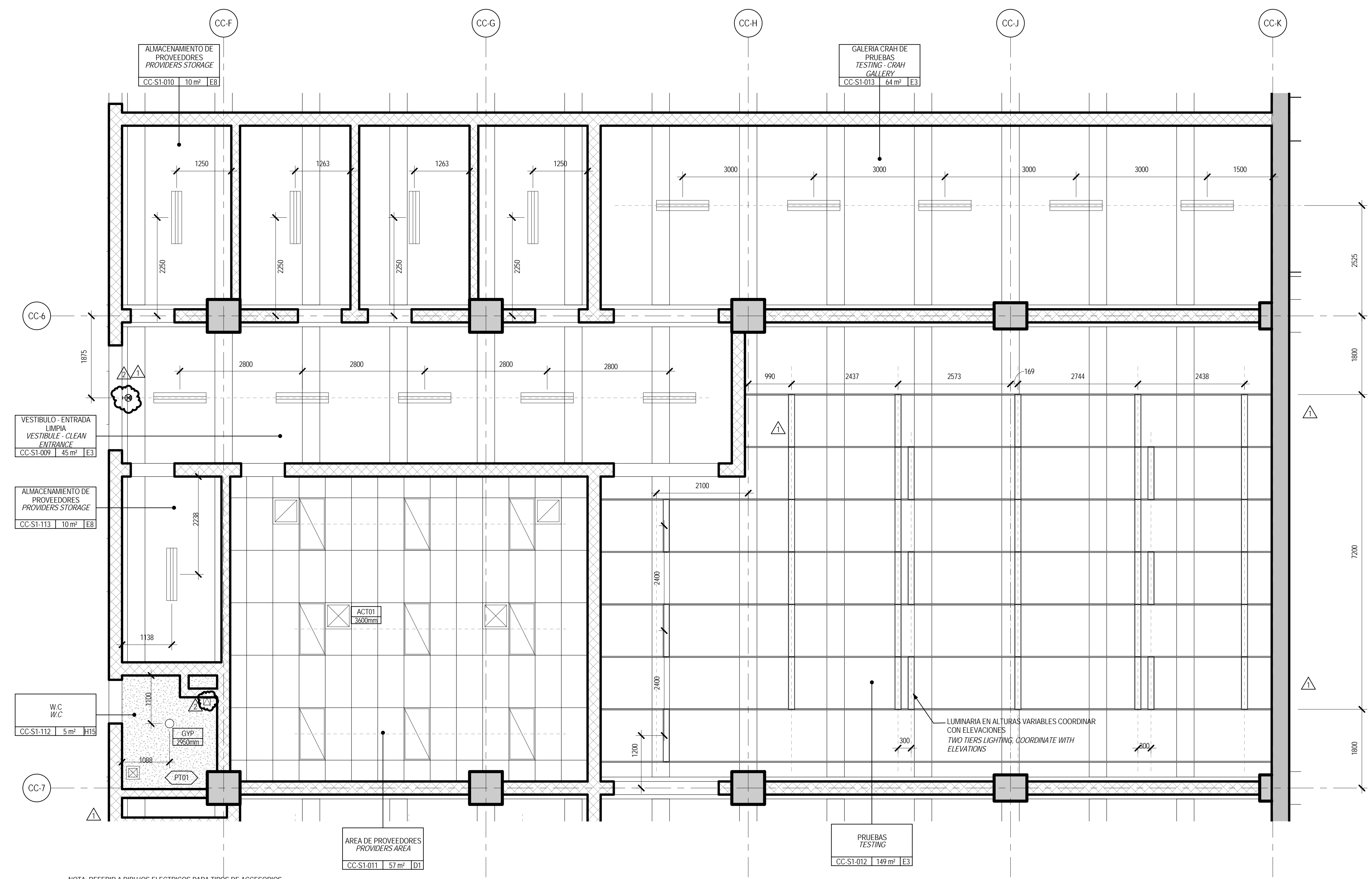

1 PLANTA DE PLAFONES S1 ZONA DE PROVEDORES Y PRUEBAS ENLARGED REFLECTED CLG. PLAN : PROVIDERS & TESTING ZONE
T : 50

NOTA: REFERIR A DIBUJOS ELECTRICOS PARA TIPOS DE ACCESORIOS
NOTE: REFER TO ELECTRICAL DRAWINGS FOR FIXTURE TYPES

APENDICE G: LISTADO DE LUMINARIAS Y FICHAS TECNICAS
APPENDIX G: LIGHTING FIXTURE SCHEDULE AND CUT SHEETS

BBVA Pabellón *BBVA Pavilion*
Listado de Luminarias *Fixture Schedule*
Diseño Esquemático *Schematic Design*
10 de Diciembre de 2012 *December 05, 2012*

TIPO <i>Type</i>	DESCRIPCION <i>Description</i>	UBICACION <i>Location</i>	ACABADOS <i>Finish</i>	LAMPARA <i>Lamp</i>	WATTAJE <i>Wattage</i>	VOLTAJE <i>Voltage</i>	FABRICANTE <i>Manufacturer</i>	NO. DE CATALOGO <i>Catalog No.</i>	DISTRIBUIDOR <i>Distributor</i>
FR	Luz LED lineal flexible de sobreponer, ubicada bajo banca, con clips de sujecion. Equipo de control remoto. <i>Surface mounted flexible linear LED under-bench light engine with mounting clip. Remote power supply required.</i>	Exteriores, Terraza de Nivel 11, Terraza de Nivel 12 <i>Site, Level 11 terrace, Level 12 terrace</i>	Estandard <i>Standard</i>	LED/3000° K	9W/LM	24V	GE	GEWWXNLE1-30K-A (EC to confirm all necessary accessories)	GE Lighting Systems www.gelightingsystems.com
FV	Luz LED hacia arriba de sobreponer, con distribucion de 10° xo 60°, lente de policarbonato, y equipo de control. Para ambiente mojado. <i>Grade surface mounted continous nominal 70mm H x 53mm W linear LED wallgrazer in extruded aluminum housing with 10°x 60° beam distribution, clear polycarbonate lens, and integral power supply.</i> <i>Coordinate mounting and wiring with wall and planter construction.</i>	Muro sembrado <i>Site living Walls</i>	Aluminio <i>Standard Aluminum</i>	LED/2700° K	49W/LM	A confirmar por Ing. Eléctrico E.E. to confirm	PHILIPS COLORKINETICS	eW Graze Powercore 2700K-10°x60°-VOLTAGE-LENGTH (EC to confirm all necessary accessories)	Philips Mexicana, S.A. De C.V. Jorge Avila Treviño +52 55 5269 9393 Mobile +52 (1) 55 3232-0720 jorge.avila@philips.com

BBVA Pabellón *BBVA Pavilion*
Listado de Luminarias *Fixture Schedule*
Diseño Esquemático *Schematic Design*
10 de Diciembre de 2012 *December 05, 2012*

TIPO <i>Type</i>	DESCRIPCION <i>Description</i>	UBICACION <i>Location</i>	ACABADOS <i>Finish</i>	LAMPARA <i>Lamp</i>	WATTAJE <i>Wattage</i>	VOLTAJE <i>Voltage</i>	FABRICANTE <i>Manufacturer</i>	NO. DE CATALOGO <i>Catalog No.</i>	DISTRIBUIDOR <i>Distributor</i>
FW	<p>Luz LED sumergible de sobreponer en muro, con distribución de 30°, cable de alimentación a 90°, y soporte ajustable. Equipo de control remoto. Coordinar con muro de fuente.</p> <p><i>Submersible wall surface mounted continuous linear LED pool edge light with 30° beam, 90° cord feed, and adjustable 75mm mounting bracket. Remote power supply required.</i></p> <p><i>Coordinate mounting and wiring with pool wall construction.</i></p>	<p>Fuente</p> <p><i>Pool</i></p>	<p>Acero Inoxidable</p> <p><i>Stainless Steel</i></p>	LED/3000° K	14W/LM	24V	WINONA	WSUB-603-LENGTH-30-30K-ND24V-A3-90C-NSS-STD	<p>Technirep</p> <p>011-52(55)-5611-1795</p>
FAC	<p>Bolardo fluorescente compacto de 1200mm con cuerpo de acero inoxidable, lente de acrílico difuso, y balastro electrónico.</p> <p><i>Grade mounted 1200mm tall compact fluorescent bollard in stainless steel housing with opal acrylic diffuser and integral electronic ballast.</i></p> <p><i>Coordinate mounting and wiring per manufacturer's installation instruction.</i></p>	<p>Exteriores</p> <p><i>Site</i></p>	<p>A confirmar por Arquitecto</p> <p><i>Architect to confirm</i></p>	FT26TTT/830	28W	A confirmar por Ing. Eléctrico E.E. to confirm	BEGA	8378P-ACRYIC DIFFUSER	<p>Lightmex</p> <p>[P]: (52) 5555599968</p> <p>info@lightmex.com</p>

BBVA Pabellón *BBVA Pavilion*
Listado de Luminarias *Fixture Schedule*
Diseño Esquemático *Schematic Design*
10 de Diciembre de 2012 *December 05, 2012*

TIPO <i>Type</i>	DESCRIPCION <i>Description</i>	UBICACION <i>Location</i>	ACABADOS <i>Finish</i>	LAMPARA <i>Lamp</i>	WATAJE <i>Wattage</i>	VOLTAJE <i>Voltage</i>	FABRICANTE <i>Manufacturer</i>	NO. DE CATALOGO <i>Catalog No.</i>	DISTRIBUIDOR <i>Distributor</i>
PA-1	<p>Luz fluorescente empotrada de 200mm x 1200mm con 2 lámparas fluorescentes, con rejillas parabólicas de reflectancia alta semi-especular, reflector parabólico, lámparas T5 ahorradoras de energía y balastro Philips Advance Optanium. Coordinar detalles de montaje con el sistema de plafon seleccionado.</p> <p>Nota: Se requiere una maqueta del método de montaje de la luminaria, en el plafon seleccionado, para verificar que el método de montaje sugerido por el fabricante no dará escapes de luz, aflojamiento o deflexión del plafon o la luminaria.</p> <p><i>Recessed nominal 200mm x 1200mm 2-lamp fluorescent downlight with booster optic parabolic semi-specular high reflectance louvers, parabolic reflector, energy-saving T5 lamp and Philips Advance Optanium ballast. Coordinate mounting detail with selected ceiling system.</i></p> <p><i>Note: Mockup of fixture mounting to selected ceiling required, to verify that manufacturer's offered mounting method will not result in light leaks or sagging/bowing of fixture or ceiling.</i></p>	<p>Oficinas</p> <p><i>Offices</i></p>	<p>Seleccionado por Arquitecto</p> <p><i>Architect to Select</i></p>	<p>Philips Energy Advantage (2) 25W/T5 3000K</p>	54W	<p>A confirmar por Ing. Eléctrico</p> <p><i>E.E. to confirm</i></p>	Zumtobel	<p>70448057M + Philips Advance Optanium IOP2S2895SC (for 25W lamp)</p>	<p>Grupo DI Jaime Casanova jjcasanova@grupodi.com</p>

BBVA Pabellón *BBVA Pavilion*
Listado de Luminarias *Fixture Schedule*
Diseño Esquemático *Schematic Design*
10 de Diciembre de 2012 *December 05, 2012*

TIPO <i>Type</i>	DESCRIPCION <i>Description</i>	UBICACION <i>Location</i>	ACABADOS <i>Finish</i>	LAMPARA <i>Lamp</i>	WATAJE <i>Wattage</i>	VOLTAJE <i>Voltage</i>	FABRICANTE <i>Manufacturer</i>	NO. DE CATALOGO <i>Catalog No.</i>	DISTRIBUIDOR <i>Distributor</i>
PB	Downlight de LED, de 100mm x 100mm cuadrado, con salida de 500 lúmenes, reflector parabólico semi-especular, y transformador integral. <i>Recessed square nominal 100mm x 100mm LED downlight, with 500 lumen output, parabolic semi-specular reflector, and integral driver.</i>	General <i>Throughout</i>	Seleccionado por Arquitecto <i>Architect to Select</i>	3000K 80+CRI LED	9W	A confirmar por Ing. Eléctrico <i>E.E. to confirm</i>	PHILIPS LIGHTOLIER	C4X4L05-DL-30K-CCD-(FINISH) + C4X4L05-N-(VOLTAGE)	Philips Mexicana, S.A. De C.V. Jorge Avila Treviño +52 55 5269 9393 Mobile +52 (1) 55 3232-0720 jorge.avila@philips.com
PG	Luminaria fluorescente de sobreponer, de 1200mm de largo, 140mm altura y 140mm de ancho, con lámparas T5 ahorradoras de energía y balastro Philips Advance Optanium y lente de acrílico. <i>Surface mounted linear fluorescent with steel housing, white acrylic lens, energy-saving T5 lamp and Philips Advance Optanium ballast.</i>	IDF / MDF / Almacén <i>IDF, MDF, Storage, Stairs</i>	Seleccionado por Arquitecto <i>Architect to Select</i>	Philips Energy Advantage (2) 25W/T5 3000K	54W	A confirmar por Ing. Eléctrico <i>E.E. to confirm</i>	PRUDENTIAL	S1-1T5-(LENGTH)-WA-(FINISH)-(VOLTAGE)-SUR + Philips Advance Optanium IOP2S2895SC	DANIEL AULISIO, PRUDENTIAL LTG. DA@PRULITE.COM 908.658.4231

Nota: Contratista deberá confirmar todos los watajes y voltajes especificados.

GE Consumer & Industrial
Lighting Systems

Tetra[®] Contour

LED ARCHITECTURAL SERIES



Tetra Contour is comprised of a flexible LED light engine and a rigid, optically diffused light guide that can be heat formed to fit a variety of architectural needs. With a variety of colors to choose from, designers can mix-n-match components to create bold designs and attractive accent lighting without the typical worries of working with fragile neon glass.

Applications

Tetra Contour is ideal for border lighting, interior art, cove and accent lighting.

Features & Benefits

- Up to 40% more energy efficient than neon
- Low voltage 24VDC system is compatible with GE LED Drivers 74917, 74915 and 74916
- Contains no lead, mercury or glass. RoHS compliant
- Long rated life of 50,000 hours
- LED light engine colors: red, green, blue, white & warm white
- Light guide colors: red, green, blue & white

a product of
ecomaginationSM



imagination at work

DISEÑO ESQUEMATICO

FMS

Proyecto **BBVA Centro Operativo**
Arquitecto **Skidmore, Owings & Merrill**

Fecha **10 de Dic de 2012**
No. Proy. **512219.00**

Tipo

FR

Fisher Marantz Stone Partners in Architectural Lighting Design 22 West 19th Street New York, NY 10011

See attached Lighting Fixture Schedule

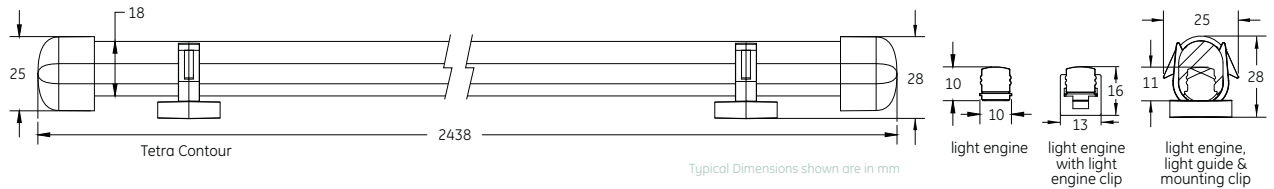

Performance Data

Product Code	Description Code	Color	Wavelength/Color Temp	Viewing Angle (light engine)	Viewing Angle (light engine w/ light guide)	Lumens ft/m (light engine)	Lumens ft/m (light engine w/ light guide)	Watts/module (light engine strip)	Watts/module (system)
75481	GERDXNLE1-A	Red	625nm	110	330	59/194	47/154	3.24	3.81
75484	GEGLXNLE1-A	Green	532nm	110	330	101/331	55/180	2.88	3.39
75485	GEBLXNLE1-A	Blue	467nm	110	330	23/75	19/162	2.88	3.39
75487	GEWWXNLE1-27K-A	White	2700K	110	330	107/351	70/230	2.88	3.39
75488	GEWWXNLE1-30K-A	White	3000K	110	330	117/384	76/249	2.88	3.39
75489	GEWWXNLE1-35K-A	White	3500K	110	330	125/410	81/266	2.88	3.39
75490	GEWWXNLE1-40K-A	White	4000K	110	330	131/430	85/279	2.88	3.39
75493	GEWHXNLE1-50K-A	White	5000K	110	330	156/512	101/331	2.88	3.39
75486	GEWHXNLE1-65K-A	White	6500K	110	330	144/472	94/308	2.88	3.39

Lumen values are typical. Allow +/- 15% for binning tolerance.

Accessories

Product Code	Description Code	Product Description	Quantity
75514	9409	18 AWG Supply Wire (0.82 mm ²)	500 ft. (152.4 m)/PK
75494	GEXNWB2	Weather Box (Outdoor Use Only)	20/PK
75498	GEXNMCAC	Light Engine Mounting Clip	20/PK
75520	GEXNMC15	Light Guide Mounting Clip	50/PK
75537	GEXNBA	Silicone Bend-Aid (Reuseable)	12/PK

For a complete list of accessories, refer to the Tetra Contour Component Guide

Light Output

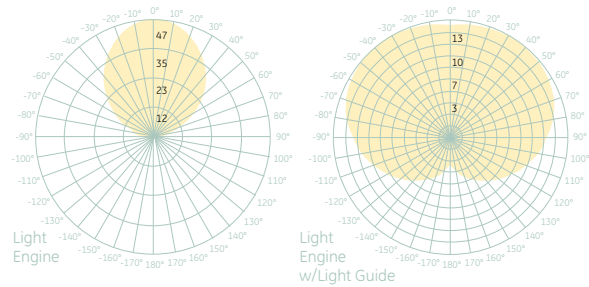

Candela (Cd) measurements taken at 6500K
IES files can be downloaded at www.gelightingsystems.com

Technical Specifications

Specification Item	Specification
Module Dimensions	0.44 in. x 0.44 in. x 16.25 in. (10 mm x 10 mm x 413 mm)
Length of Light Engine	8 ft. (2.44 m)
Light Engine Packaging Quantity	Red only - 12/PK, All other colors - 6/PK
GE LED Drivers	74917 (GE020/G/V24T1-B), 74915 (GE080/G/V24T1-A) & 74916 (GE100/MV/V24T1-A)
Operating Voltage	24 VDC
Minimum Loading	74917, 74915 & 74916: 8 in. (0.20 m)
Maximum Loading	74917: 6 ft. (1.83 m) 74915: 24 ft. (7.32 m) 74916: 30 ft. (9.14 m)
Ambient Temperature	-40°C to +55°C
Limited Warranty	Up to 5 years
IP Rating	IP66: Dry, damp or wet location rated
System Certifications	



Tetra is a trademark of Lumination, LLC. The GE brand and logo are trademarks of the General Electric Company.
Photograph courtesy of Blake Marvin-HKS, Inc.

USA
GE Lighting Systems
3010 Spartanburg Hwy.
East Flat Rock, NC 82726
T+1.828.693.2000
F+1.828.693.2570

Visit us online at:
www.gelightingsystems.com

© 2009 General Electric Company
All Rights Reserved

ARCH039-R100909
OLP-2874

DISEÑO ESQUEMATICO



Proyecto **BBVA Centro Operativo**
Arquitecto **Skidmore, Owings & Merrill**

Fecha **10 de Dic de 2012**
No. Proy. **512219.00**

Tipo



Fisher Marantz Stone Partners in Architectural Lighting Design 22 West 19th Street New York, NY 10011

GE Consumer & Industrial
Lighting Systems

GEH-5995A
Installation Guide

24
Volt

LED Driver

Product Code #74916

Description Code #GE100/MV/V24T1-A

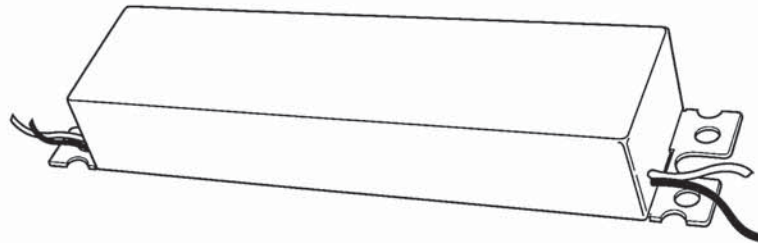

BEFORE YOU BEGIN

Read these instructions completely and carefully.

⚠ WARNING / AVERTISSEMENT

Risk of electrical shock. Disconnect power before servicing or installing product. / **Risque de choc électrique.** Couper l'alimentation avant le dépannage ou avant l'installation du produit.

LED Driver Features

- Class 2 wiring per NEC Article 725 (SELV)
- IP52: Dry or damp location rated
- Conforms to the following standards



Prepare Electrical Wiring



Electrical Requirements

- The LED driver must be supplied with 120/277V, 60Hz or 240V, 50Hz and connected to an individual properly grounded branch circuit, protected by a 15 or 20 ampere circuit breaker.



Grounding Instructions

- The grounding and bonding of the overall system shall be done in accordance with National Electric Code (NEC) Article 600 and local codes.

NOTE: This device complies with Part 15 of the FCC Rules. Operation is subject to the following two conditions: (1) this device may not cause harmful interference, and (2) this device must accept any interference received, including interference that may cause undesired operation.

This Class [A] RFLD complies with the Canadian standard ICES-005. Ce DEFR de la classe [A] est conforme à la NMB-005 du Canada.



imagination at work

DISEÑO ESQUEMATICO

FMS

Proyecto **BBVA Centro Operativo**
Arquitecto **Skidmore, Owings & Merrill**

Fecha **10 de Dic de 2012**
No. Proy. **512219.00**

Tipo

FR

LED Driver Installation

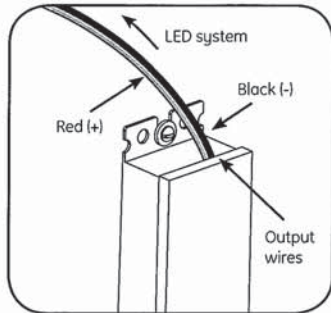

1 Connect the AC line to the black (line) and white (neutral) input wires of the LED driver using 18-14 AWG (0.82-2.08 mm²) twist-on wire connectors.

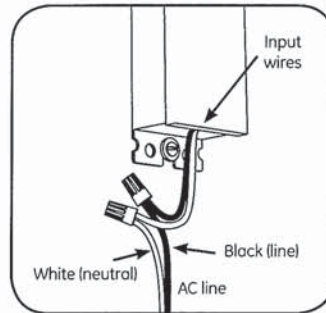

2 Connect the supply wire that is attached to your LED system to the red (+) and black (-) output wires of the LED driver as outlined in the "Electrical Connections" section of your LED system's Installation Instructions.

To ensure the LED driver load and remote mounting distances are within the ranges specified in the product installation guide.

Technical Specifications

	Min	Typical	Max
Input Voltage (VAC)	108	120-277	305
Input Frequency (HZ)	-	50/60	-
Input Current (A)	0.4	0.6	1
Output Voltage (VDC)	24.25	25.00	25.75
Output Current (ADC)	-	-	4.1
Output Power (W)	-	-	100
Environmental Operating Temperature Range	-40°C	+25°C	+55°C*
Environmental Humidity (non-condensing)	0%	-	95%
Environmental Storage Temperature Range	-40°C	-	+85°C
Enclosure Specification	IP52: Dry or damp location rated		
Dimensions	9.5 in. x 1.7 in. x 1.2 in. (240 mm x 43 mm x 30 mm)		

NOTE: For remote mounting or loading information refer to the LED System Installation Instructions.
*Maximum case temperature is 90°C

USA
GE Lighting Systems
3010 Spartanburg Hwy.
East Flat Rock, NC 28726
T+1.828.693.2000
F+1.828.693.2570
Visit us online at:
www.gelighting.com

© 2009 General Electric Company
All Rights Reserved
ARCH029-R070210
GEH-5995 35-201578-187

DISEÑO ESQUEMATICO

Ver listado de luminarias

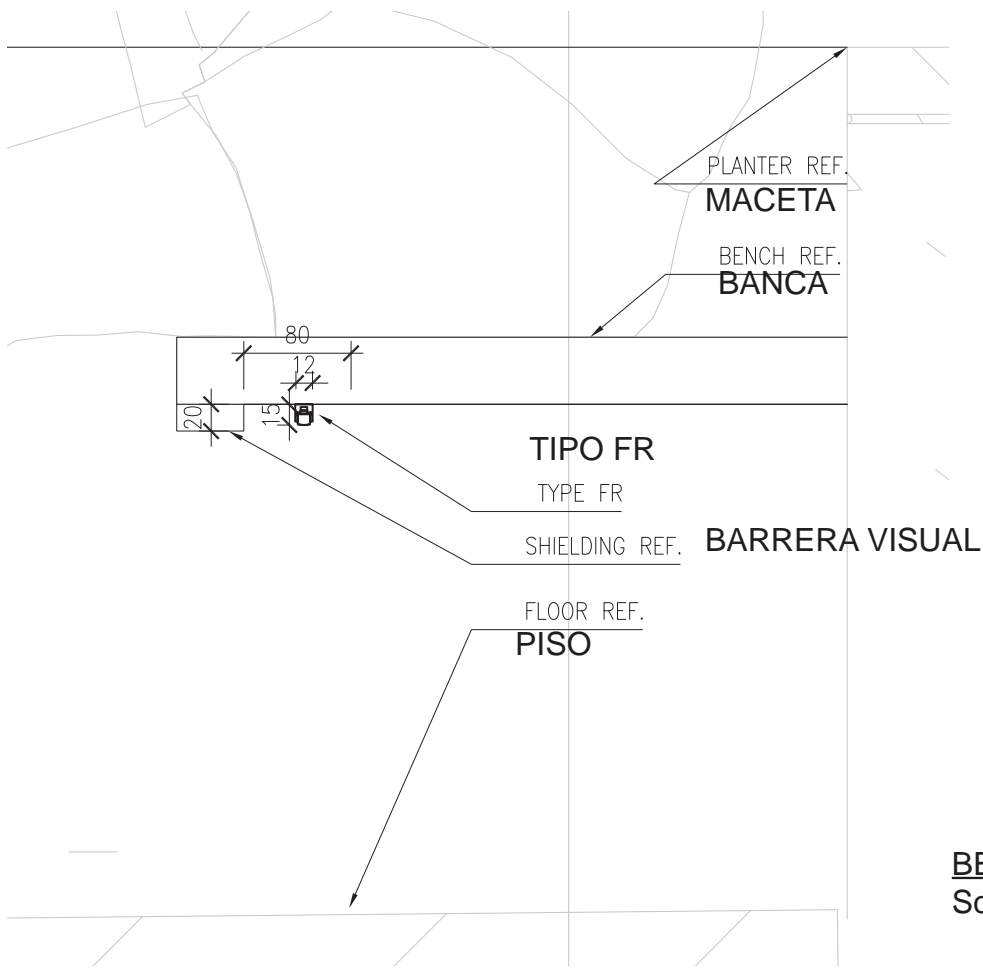

BENCH MOUNTING DETAIL
Scale: N.T.S

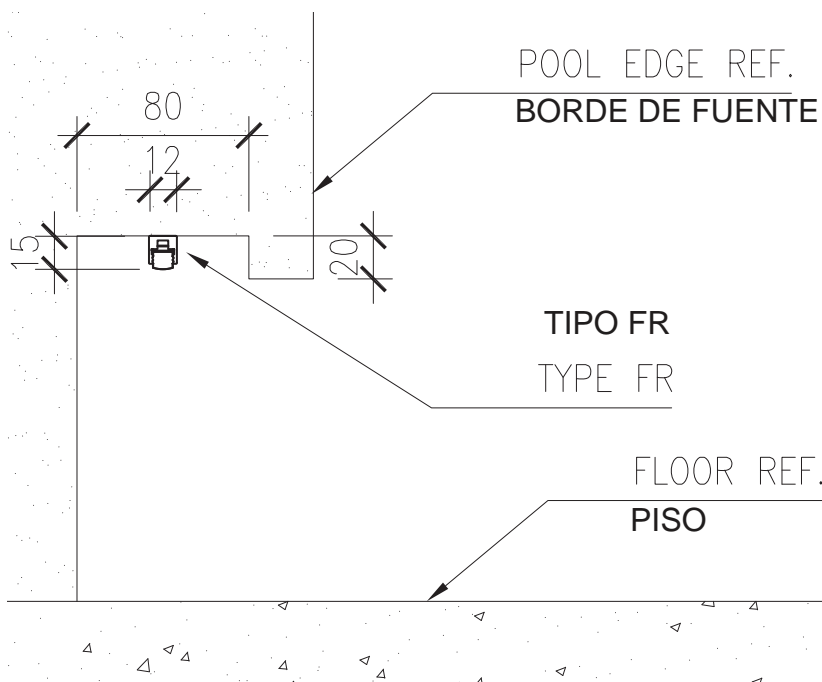

POOL EDGE MOUNTING DETAIL
Scale: N.T.S

DISEÑO ESQUEMATICO



Proyecto **BBVA Centro Operativo**
Arquitecto **Skidmore, Owings & Merrill**

Fecha **10 de Dic de 2012**
No. Proy. **512219.00**

Tipo



Specifications

Due to continuous improvements and innovations, specifications may change without notice.

Item	Specification	1 ft (305 mm)	4 ft (1.2 m)	
Output	Beam Angle	10° x 60°		
	Color Temperature	2700 K (+375 / -300)		
	Lumens†	404	1616	
	Efficacy (Lm/W)	26.9		
	Mixing Distance	6 in (152 mm) to uniform beam saturation		
	Lumen Maintenance‡	100,000+ hours L70 @ 25° C 50,000 hours L70 @ 50° C		
	Electrical	Input Voltage	100 / 120 / 220 – 240 / 277 VAC, 50 / 60 Hz	
Power Consumption		15 W maximum at full output, steady state 60 W maximum at full output, steady state		
Control		Commercially available ELV control dimmers		
Physical	Dimensions (Height x Width x Depth)	2.7 x 12 x 2.8 in (69 x 305 x 71 mm)	2.7 x 48 x 2.8 in (69 x 1219 x 71 mm)	
	Weight	2.7 lb (1.2 kg)	10.8 lb (4.9 kg)	
	Housing	Extruded anodized aluminum		
	Lens	Clear polycarbonate		
	Fixture Connectors	Integral male / female waterproof connectors		
	Mounting	Multi-positional, constant torque locking hinges		
	Temperature	-40° – 122° F (-40° – 50° C) Operating -4° – 122° F (-20° – 50° C) Startup		
	Humidity	0 – 95%, non-condensing		
	Fixture Run Lengths*	88 @ 110 VAC 97 @ 20 VAC 180 @ 220 VAC 197 @ 240 VAC	Configuration: 1 ft (305 mm) fixtures installed end-to-end, 20 A circuit, standard 50 ft (15.2 m) Leader Cable	
	Certification and Safety	Certification	UL / cUL, FCC Class A, CE, RoHS, WEEE	
LED Class		Class 2 LED product		
Environment		Dry / Damp / Wet Location, IP66		

† Lumen measurement complies with IES LM-79-08.

‡ L70 = 70% maintenance of lumen output. (When light output drops below 70% of initial output.)

* These figures, provided as a guideline, are accurate for this configuration only. Changing the configuration can affect the fixture run lengths.



Photometrics

2700 K, 1 ft, 10° x 60° lens

Polar Candela Distribution

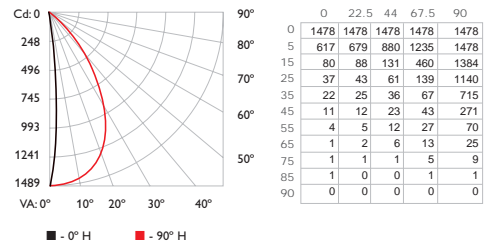

Illuminance at Distance

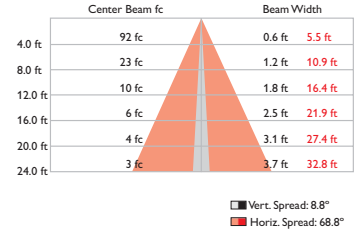

Power Consumption	15 W
Lumens	404
Efficacy	26.9 Lm/W

For lux multiply fc by 10.7

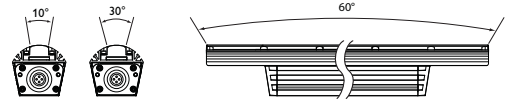

OPTIBIN® | POWERCORE® | DIMAND®
CK TECHNOLOGY | CK TECHNOLOGY | CK TECHNOLOGY

Fixtures

Item	Beam Angle	Voltage	Size	Item Number	Philips 12NC
eW Graze Powercore 2700 K	10° x 60°	120 VAC	1 ft	523-000030-00	910503700276
			4 ft	523-000030-02	910503700278
		277 VAC	1 ft	523-000030-08	910503700284
			4 ft	523-000030-10	910503700286
		220 – 240 VAC	1 ft	523-000030-16	910503700292
			4 ft	523-000030-18	910503700294
		100 VAC	1 ft	523-000030-24	910503700300
			4 ft	523-000030-26	910503700302

Use Item Number when ordering in North America.

Accessories

Item	Type	Size	Item Number	Philips 12NC	
Leader Cable	UL / cUL	50 ft (15.2 m)	108-000041-00	910503700320	
	CE		108-000041-01	910503700320	
Jumper Cable	UL / cUL	End-to-End	108-000039-00	910503700314	
			1 ft (305 mm)	108-000039-01	910503700315
			5 ft (1.5 m)	108-000039-02	910503700316
	CE	End-to-End	108-000040-00	910503700317	
			1 ft (305 mm)	108-000040-01	910503700318
			5 ft (1.5 m)	108-000040-02	910503700319
Glare Shield		1 ft (305 mm)	120-000081-00	910503700745	
		2 ft (610 mm)	120-000081-01	910503700746	
		3 ft (914 mm)	120-000081-02	910503700747	
		4 ft (1.2 m)	120-000081-03	910503700748	



Philips Color Kinetics
3 Burlington Woods Drive
Burlington, Massachusetts 01803 USA
Tel 888.385.5742
Tel 617.423.9999
Fax 617.423.9998
www.colorkinetics.com

Copyright © 2008 – 2009 Philips Solid-State Lighting Solutions, Inc. All rights reserved. Chromacore, Chromasic, CK, the CK logo, Color Kinetics, the Color Kinetics logo, ColorBlast, ColorBlaze, ColorBurst, ColorGraze, ColorPlay, ColorReach, DIMand, EssentialWhite, eW, iColor, iColor Cove, IntelliWhite, iW, iPlayer, Light Without Limits, Optibin, and Powercore are either registered trademarks or trademarks of Philips Solid-State Lighting Solutions, Inc. in the United States and/or other countries. All other brand or product names are trademarks or registered trademarks of their respective owners. Due to continuous improvements and innovations, specifications may change without notice.

DAS-000009-01 R04 07-09

DISEÑO ESQUEMATICO



Proyecto **BBVA Centro Operativo**
Arquitecto **Skidmore, Owings & Merrill**

Fecha **10 de Dic de 2012**
No. Proy. **512219.00**

Tipo



2 of 3

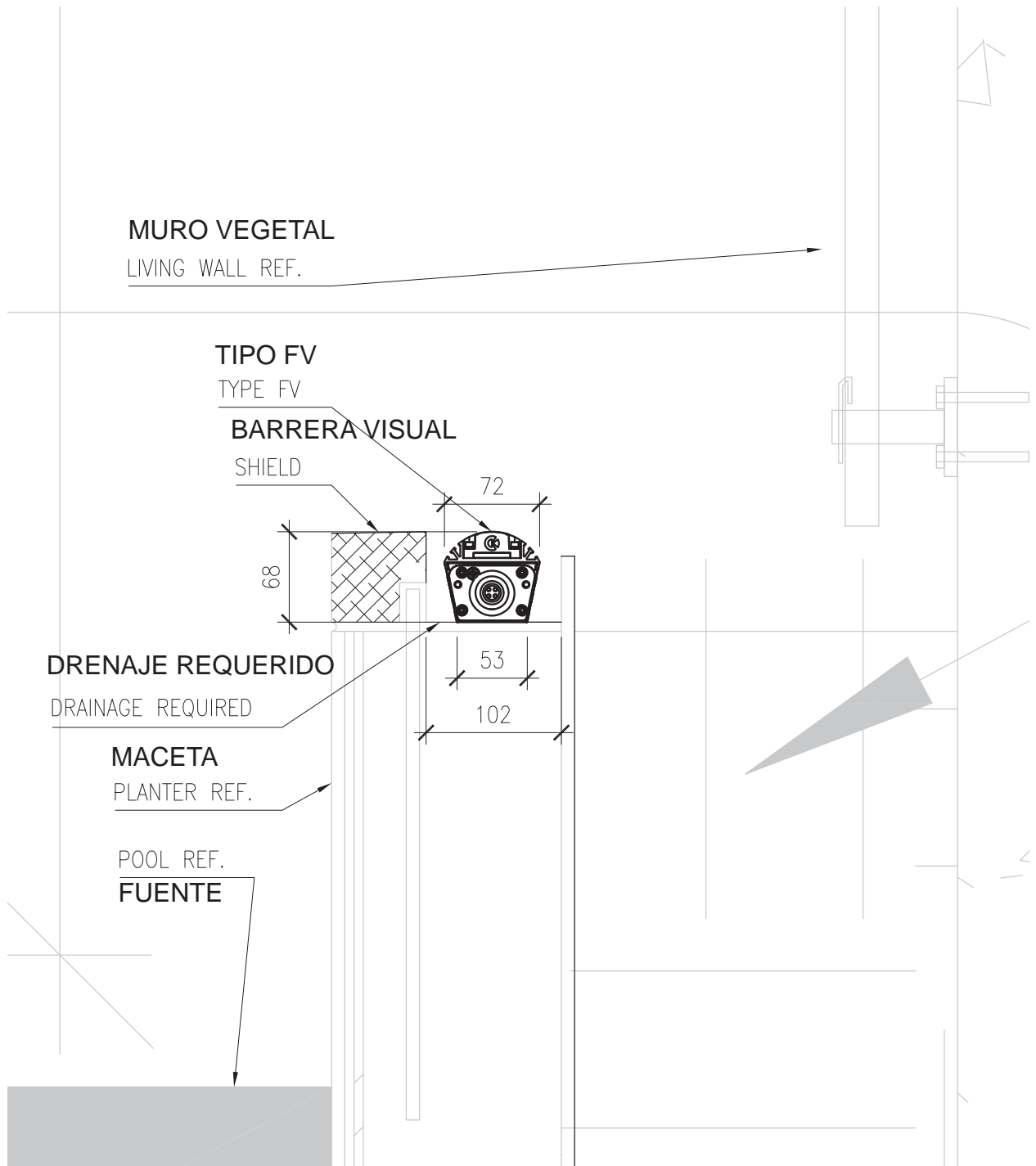

DETALLE DE INSTALACION

MOUNTING DETAIL

Scale: N.T.S

DISEÑO ESQUEMATICO

Ver listado de luminarias

winonaLED

Project: _____

Qty: _____

Type:

winline submersible 603 wet/dry

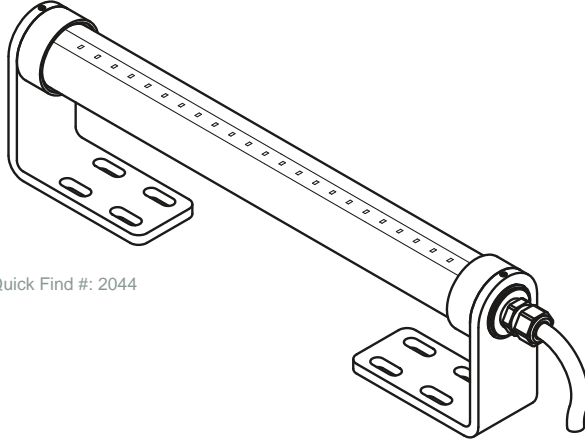

Quick Find #: 2044

The **Winline 603** submersible linear luminaire is designed to be the most powerful, reliable, and easiest to implement submersible solution available. The Model 603 is suitable for installation up to 3 meters deep in fountains and other water containing vessels not intended to accommodate the partial or complete immersion of persons.

Color & Light Output: The Model 603 utilizes Nichia 123B white LEDs in five standard colors and features (24) LEDs/ft.

Color	Model 603
ANSI-2700K White	125 lm/ft
ANSI-3000K White	147 lm/ft
ANSI-3500K White	153 lm/ft
ANSI-4000K White	163 lm/ft
non-ANSI-5000K White	186 lm/ft

Results based on BALL test 15372
140° beam spread
Note:
LM79 Tests- see page 4.

Beam Spreads: The Model 603 is available in two beam spreads. The narrow 30 degree beam is useful for uplighting walls and waterfalls. The wide 140 degree can be used to illuminate larger underwater planes. See page 4 for photometric data.

Power: Winline 603 power consumption is 4.5W/ft. The Winline 603 operates on 24VAC using Magnetic Transformers. A wide range of remote transformers are available in 120V. **Note: NEC requires the primary side of the transformer to be protected by a ground fault circuit interrupter. NEC also stipulates a maximum of 150V on primary side of transformer. Please reference NEC codes and all local codes for detailed information.**

Dimming: Used with remote mounted 24VAC magnetic transformers which can be dimmed with commonly available low voltage magnetic dimming equipment.

Mounting & Adjusting: A unique 1-piece adjustable mount allows for 360 degree rotation enabling the fixture to be mounted anywhere. The stainless steel mounts can be bolted to pool surfaces or fasten them to paving stones to avoid penetrations in waterproofing membranes. **Note: Per NEC the fixture must be able to be removed for maintenance and inspection without adjustment of the water level.** Two endcap configurations are available. The standard straight exit cap is used when there are no restrictions around the luminaire. Use the 90 degree endcap for continuous row mounting. See pages 2-3 for more mounting and adjustment information.

Operating Temperature: 35°F to 90°F (2°C to 32°C) - submersed
-30°F to 122°F (-35°C to 50°C) - wet out of water

Weight:

12" - 3.9 lbs	36" - 6.0 lbs
18" - 4.4 lbs	42" - 6.6 lbs
24" - 5.0 lbs	48" - 7.1 lbs
30" - 5.5 lbs	



Winline 603 is ETL listed for submersible locations. Complies with UL Standard 676



IP68



Winona Lighting | 3760 West Fourth Street | Winona, MN 55987 | 800-328-5291 | www.winonalighting.com
Revision 5/25/10

Winline Submersible - WSUB	WSUB	series
model 603 wet/dry - 603	603	model
12 inch - A 18 inch - B 24 inch - C 30 inch - D 36 inch - E 42 inch - F 48 inch - G		length
30° - 30 140° - 140		beam spread
ANSI-binned 2700K - 27K ANSI-binned 3000K - 30K ANSI-binned 3500K - 35K ANSI-binned 4000K - 40K non-ANSI-binned 5000K - 50K		LED code
non-dimming 24 volt AC - ND24V dimming 24 volt AC - DM24V		voltage
adjustable 3" mount bracket - A3 adjustable 6" mount bracket - A6 adjustable 9" mount bracket - A9		mount
straight cord feed - SC 90° cord feed - 90C		power feed
<i>Metal Finish</i> Exterior metal finish is Alloy 316 Stainless Steel - NSS	NSS	finish
standard - STD modified - MOD		special
Describe Modification: <div style="border: 1px solid black; height: 50px; width: 100%;"></div>		

DISEÑO ESQUEMATICO



Proyecto **BBVA Centro Operativo**
Arquitecto **Skidmore, Owings & Merrill**

Fecha **10 de Dic de 2012**
No. Proy. **512219.00**

Tipo



winonaLED

winline submersible 603 wet/dry

mounting

The Winline 603 is available in seven lengths up to 48" in 6" increments starting at 12".

Mounting

Power cable can be specified as straight exit or 90 degree exit for continuous mounting. Stainless steel mounting brackets are offered in three different heights for attachment to existing structure, paving stones, boulders, or blocks.

Straight Cord Feed

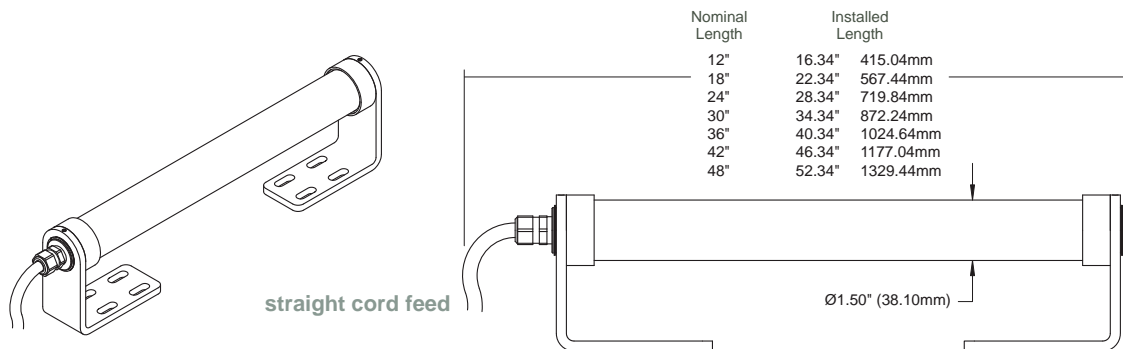

90° Cord Feed

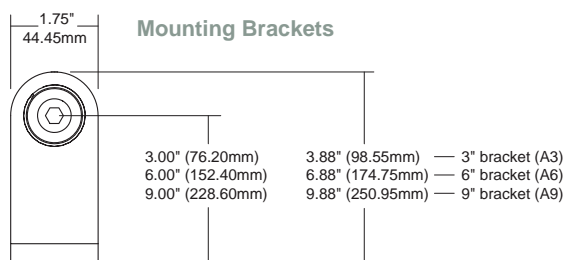
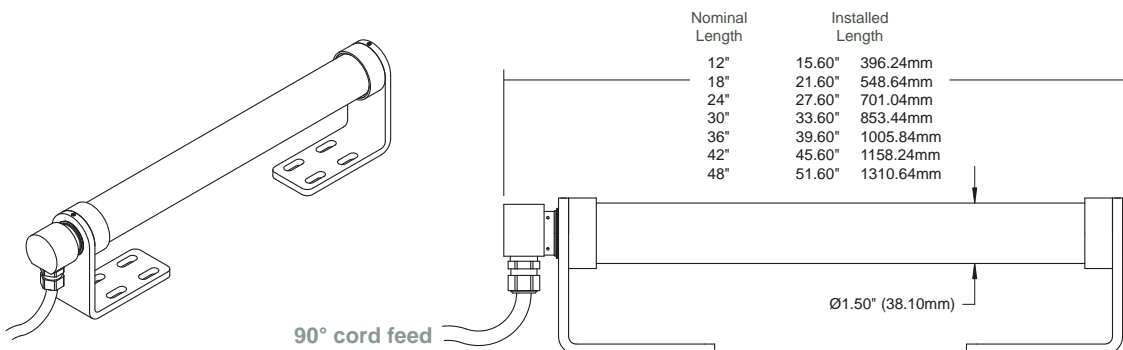

DISEÑO ESQUEMATICO



winonaLED

winline submersible 603 wet/dry

power, dimming, and wiring

The WINLINE 603 is to be powered by 24VAC only. **Do not connect directly to line voltage under any circumstance.** Connection to line voltage will permanently damage internal components and void manufacturer's warranty.

POWER REQUIREMENTS

WINLINE 603 consumes 4.5W/ft. Winline 603 is only available in single units (minimum of 24VAC is required at feed end of unit cord). The WINLINE 603 must be powered by a magnetic transformer. **Do not use electronic transformers.** Choose a transformer with adequate capacity. Total load should not exceed 80% of the rated output of the transformer at 24VAC. **Note: NEC requires transformer supply voltage to be less than 150 volts between conductors. In addition the primary side of the transformer is to be protected by a ground fault circuit interrupter. Please reference NEC codes and all local codes for detailed information.**

DIMMING

The WINLINE 603 is easily dimmed with Magnetic Low Voltage (MLV) Dimmers. Not all MLV dimmers are alike, even among the same manufacturer. Confirm with dimming equipment manufacturer that dimmer selected is designed to work with the transformer selected.

MOUNTING, AIMING AND WIRING

Fountain use only.
Not rated for pool and spa use.

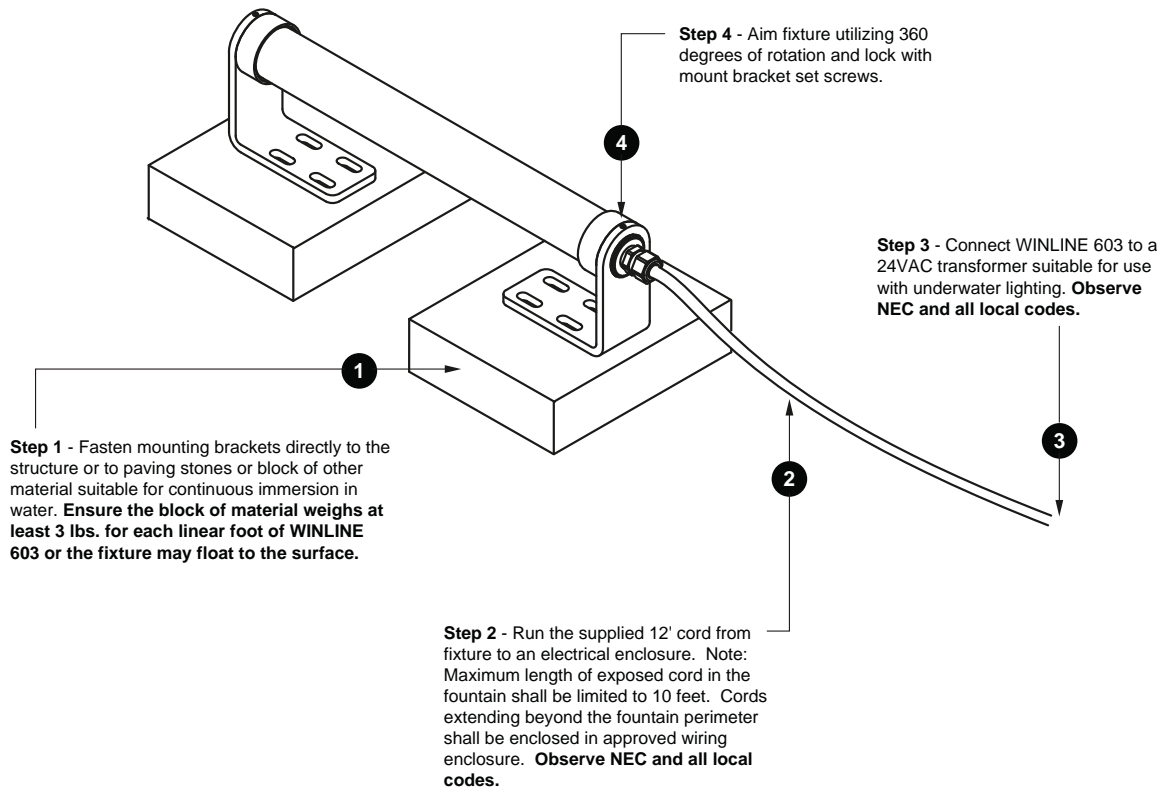

DISEÑO ESQUEMATICO



Ver listado de luminari

winonaLED

winline submersible 603 wet/dry

photometrics

30°

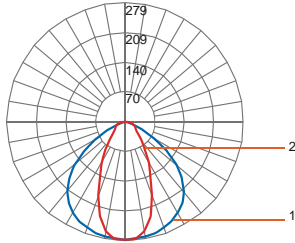

Maximum Candela = 279 Located At Horizontal Angle = 67.5, Vertical Angle = 5
 #1 - Vertical Plane Through Horizontal Angles (0-180)
 #2 - Vertical Plane Through Horizontal Angles (90-270)

BALL Test Report: 15373 Catalog Number: WSUB-603-36-30-30K
 Description: 72 Nichia 123B LEDs / 36" WSUB603 Submersible Luminaire / Extruded Aluminum Housing / Acrylic Lens

LM79 Data - Based on WSUB603 30° Test Results

Color	Total Lumens	Lamp Watts	Lumens per Watt	CRI	Power Factor
ANSI-binned 2700K	351	12.3	28.5	84.3	.97
ANSI-binned 3000K	372	12.3	33.6	87.0	.98
ANSI-binned 3500K	387	12.3	35.0	83.0	.98
ANSI-binned 4000K	413	12.3	37.2	87.0	.98
non-ANSI-binned 5000K	471	12.3	38.3	70.3	.98

Zonal Lumen Summary		Zone	Lumens	%Fixture
Nichia 123B 3000K		0-30	188	45.4
		0-40	274	66.3
		0-60	374	90.4
		0-90	413	100.0
Total Luminaire		0-180	413	100.0

Candlepower Distribution 3000K

Angle	Horizontal Plane				
	0	22.5	45	67.5	90
0	278	278	278	278	278
5	275	277	278	279	278
10	274	277	271	265	262
15	271	269	254	235	230
20	264	261	226	193	184
25	257	249	183	147	139
30	246	228	142	118	112
35	233	193	110	89	82
40	214	150	77	62	61
45	187	104	52	45	44
50	156	66	37	33	34
55	119	43	27	27	30
60	79	31	21	26	27
65	46	20	17	21	24
70	24	14	15	19	20
75	11	10	11	15	17
80	3	4	9	10	11
85	0	1	4	4	5
90	0	0	0	0	0

140°

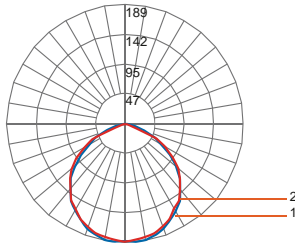

Maximum Candela = 189 Located At Horizontal Angle = 0, Vertical Angle = 5
 #1 - Vertical Plane Through Horizontal Angles (0-180) (Through Max. Cd.)
 #2 - Vertical Plane Through Horizontal Angles (90-270)

BALL Test Report: 15372 Catalog Number: WSUB-603-36-140-30K
 Description: 72 Nichia 123B LEDs / 36" WSUB603 Submersible Luminaire / Extruded Aluminum Housing / Acrylic Lens

LM79 Data - Based on WSUB603 140° Test Results

Color	Total Lumens	Lamp Watts	Lumens per Watt	CRI	Power Factor
ANSI-binned 2700K	375	12.1	31.0	84.3	.97
ANSI-binned 3000K	441	12.1	40.5	87.0	.97
ANSI-binned 3500K	459	12.1	42.1	83.0	.97
ANSI-binned 4000K	490	12.1	45.0	87.0	.97
non-ANSI-binned 5000K	559	12.1	46.2	70.3	.97

Zonal Lumen Summary		Zone	Lumens	%Fixture
Nichia 123B 3000K		0-30	147	29.9
		0-40	240	49.0
		0-60	418	85.3
		0-90	490	100.0
Total Luminaire		0-180	490	100.0

Candlepower Distribution 3000K

Angle	Horizontal Plane				
	0	22.5	45	67.5	90
0	187	187	187	187	187
5	189	188	186	187	185
10	188	186	183	184	183
15	183	182	180	181	180
20	178	178	177	174	174
25	169	169	168	165	167
30	160	162	158	155	156
35	151	151	149	147	149
40	136	137	136	137	136
45	123	122	125	122	124
50	105	106	110	109	111
55	87	90	93	94	94
60	67	73	76	77	76
65	51	55	59	59	57
70	31	37	41	29	22
75	16	22	15	9	6
80	5	10	4	4	3
85	0	1	1	1	1
90	0	0	0	0	0

lighting facts CM
 A Program of the U.S. DOE

Light Output (Lumens) 490
Watts 12.1
Lumens per Watt (Efficacy) 40

Color Accuracy
 Color Rendering Index (CRI) 69

Light Color
 Correlated Color Temperature (CCT) 2895 (Warm White)

Warm White | Bright White | Daylight
 2700K | 3000K | 4500K | 6500K

All results are according to IESNA LM-79-2008: Approved Method for the Electrical and Photometric Testing of Solid-State Lighting. The U.S. Department of Energy (DOE) verifies product test data and results.

Visit www.lightingfacts.com for the Label Reference Guide.

Registration Number: 84Q4-P1NGMF
 Model Number: WSUB-603-3-140-30K
 Type: Other



Winona Lighting | 3760 West Fourth Street | Winona, MN 55987 | 800-328-5291 | www.winonalighting.com

DISEÑO ESQUEMATICO



Proyecto **BBVA Centro Operativo**
 Arquitecto **Skidmore, Owings & Merrill**

Fecha **10 de Dic de 2012**
 No. Proy. **512219.00**

Tipo



Ver listado de luminarias

winonaLED

Project: _____

Qty: _____

Type:

Magnetic LED Transformer - Multiple Output (22V, 24V, 26V, 28V, 30V)



FEATURES

- Manufactured by Q-Tran
- 18 gauge steel
- 8 knockouts
- Built in support bracket incorporated to secure housing for surface mounting
- Multiple Volt and Taps:
Two primary taps
Four secondary taps provide voltages of:
24V = 22V, 24V, 26V, 28V, 30V
- Loads may be connected to one or more of the secondary taps up to the full watt rating of the TQ series
- Loads at varying distances can be tapped on different taps to recover voltage drop and produce between 85% - 100% light output



1. TQ model	TQ - Magnetic Multiple Output Transformer
2. wattage	150 - 150W 300 - 300W 500 - 500W 600 - 600W
3. primary voltage	120 - 120V 277 - 277V
4. 24V secondary voltage	24V - 24 Volt AC
5. BLK finish	BLK - Black Powder Coat

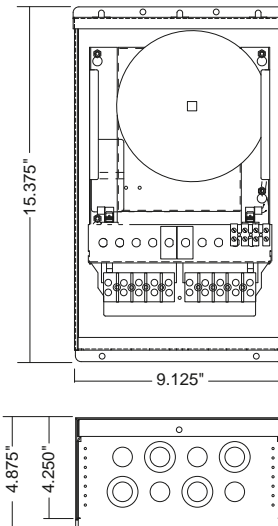

winona
lighting

3760 west fourth street • winona, minnesota 55987 • 507 - 454 - 5113 • fax: 507 - 454 - 1814
winona lighting on the web • www.winonalighting.com

Revised: 6-30-10 Page 1 of 1

DISEÑO ESQUEMATICO

FMS

Proyecto **BBVA Centro Operativo**
Arquitecto **Skidmore, Owings & Merrill**

Fecha **10 de Dic de 2012**
No. Proy. **512219.00**

Tipo

FW
5 of 6

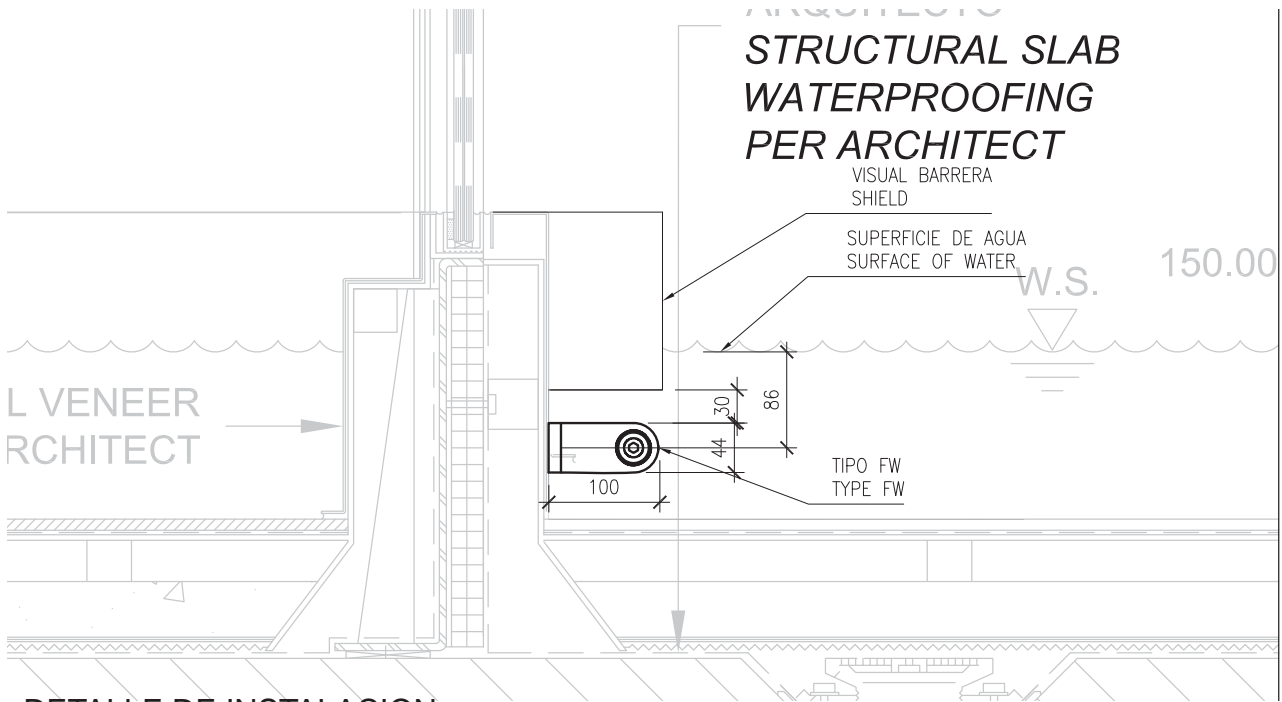

DETALLE DE INSTALACION

MOUNTING DETAIL - EXTERIOR

Scale: N.T.S

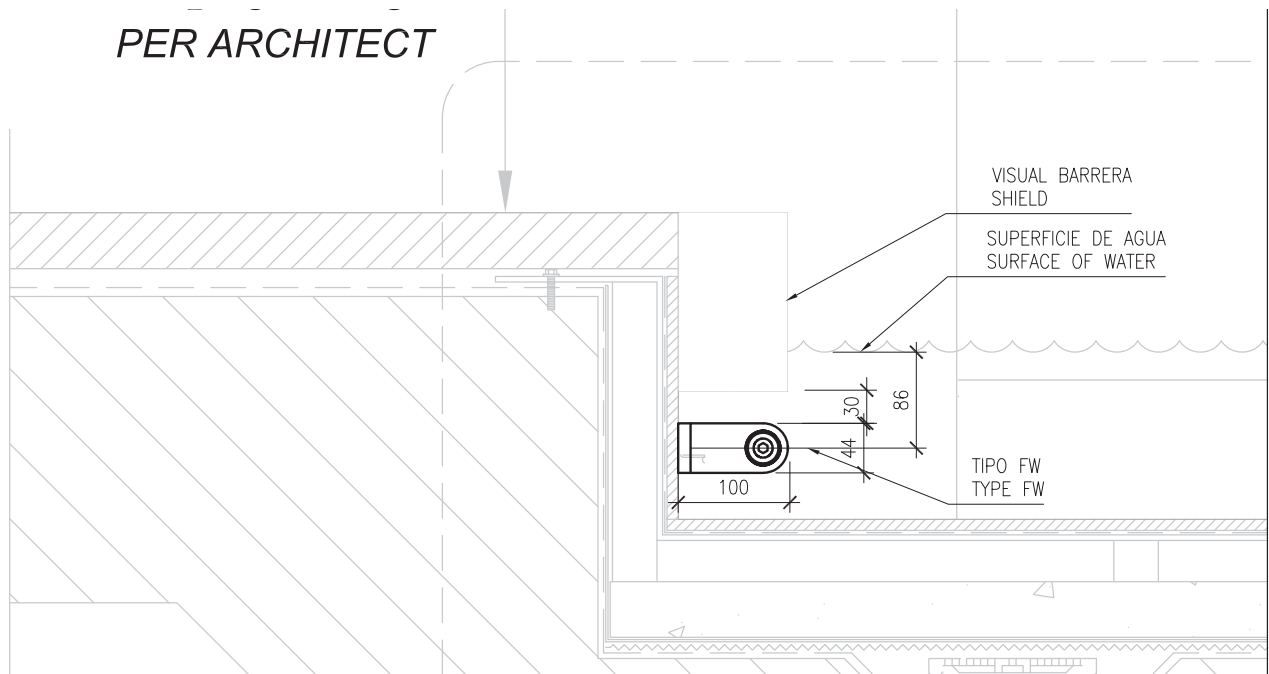

DETALLE DE INSTALACION

MOUNTING DETAIL - INTERIOR

Scale: N.T.S

DISEÑO ESQUEMATICO



Proyecto **BBVA Centro Operativo**
 Arquitecto **Skidmore, Owings & Merrill**

Fecha **10 de Dic de 2012**
 No. Proy. **512219.00**

Tipo



Bollard · STAINLESS STEEL

Post construction: Seamless stainless steel tubing with a machined top insert and a machined base internally welded into an assembly.

Lamp enclosure: One piece, handblown three-ply opal glass. Fully gasketed using high temperature silicone rubber O-ring gaskets.

Electrical: Lampholders; G24q-3 rated 75W, 250V (26W). Ballasts are electronic, universal voltage 120V through 277V.

Anchor base: Heavy gauge stainless steel with four (4) threaded stainless steel studs which accept BEGA #896 A anchorage kit (supplied).

Finish: #4 brushed stainless steel. Stainless steel requires regular cleaning and maintenance, much like household appliances, to maintain its luster and to prevent tarnishing or the appearance of rust like stains.

U.L. listed, suitable for wet locations. Protection class: IP 65.

Type:
 BEGA Product:
 Project:
 Voltage:
 Color:
 Options:
 Modified:



	Lamp	Lumen	A	B	C	Anchorage
8378 P	1 26W CF quad-4p	1800	4 1/4	47 1/4	8 7/8	896 A

BEGA-US 1000 BEGA Way, Carpinteria, CA 93013 (805) 684-0533 FAX (805) 566-9474 www.bega-us.com
 ©copyright BEGA-US 2008 Updated 2/08

DISEÑO ESQUEMATICO



Proyecto **BBVA Centro Operativo**
 Arquitecto **Skidmore, Owings & Merrill**

Fecha **10 de Dic de 2012**
 No. Proy. **512219.00**

Tipo **FAC**

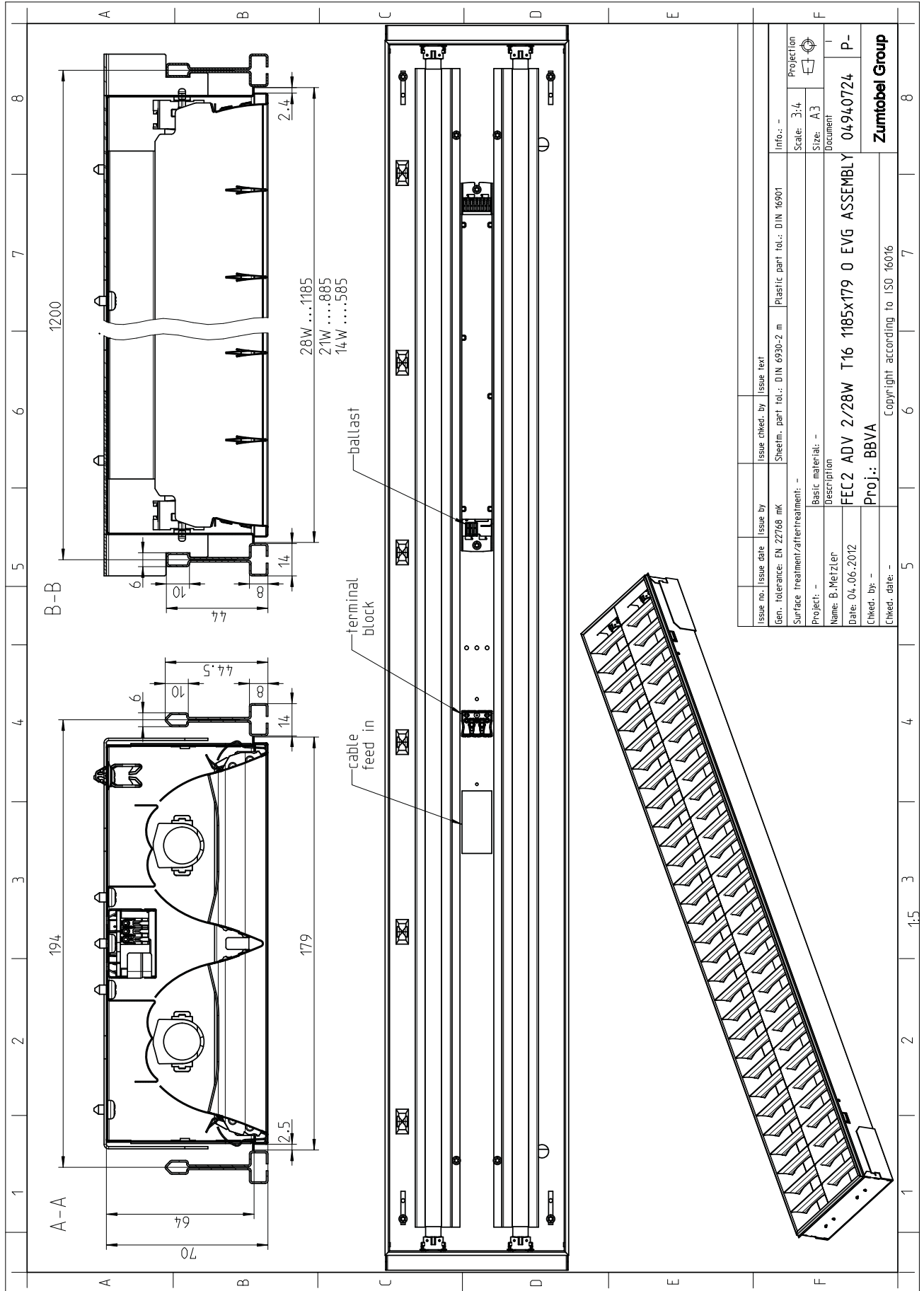

DISEÑO ESQUEMATICO



Proyecto **BBVA Centro Operativo**
 Arquitecto **Skidmore, Owings & Merrill**

Fecha **10 de Dic de 2012**
 No. Proy. **512219.00**

Tipo **PA-1**



42178019 FEC2 ADV 2/54W T16 M600

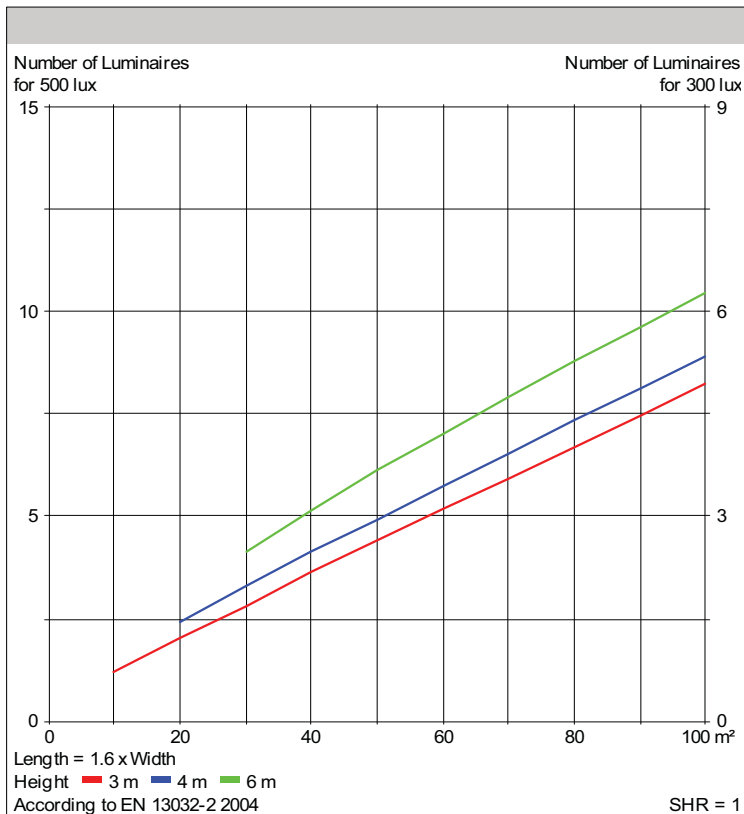
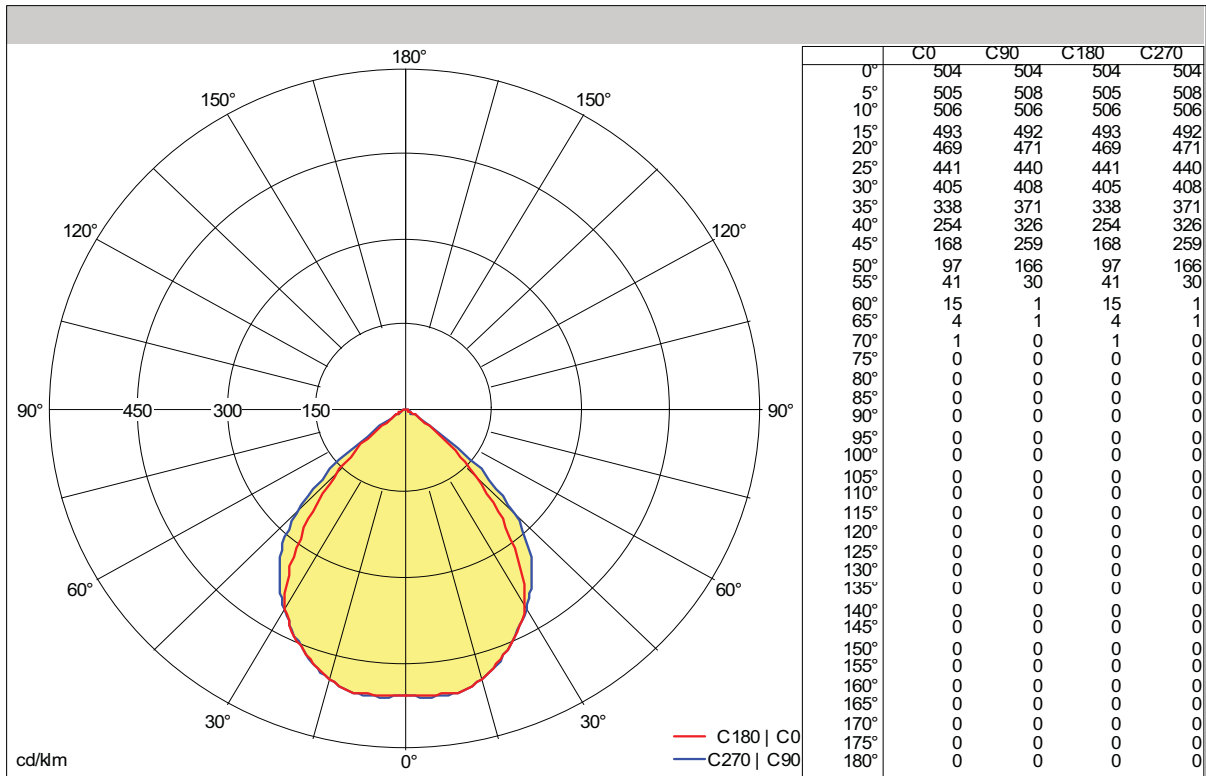

Light output ratio	
LOR	85 %
ULOR	0 %
DLOR	85 %
FFR	0.00 (0:100)
BLF	1.00

Glare Evaluation	
X = 4 H, Y = 8 H	S = 0.25 H
Reflection factors	70/50/20
UGR transversal	<19
UGR axial	<19
65° < 1000 cd/m²	

Classification	
LiTG	A60
LG7	65° < 1000cd/m²
BZ	BZ1
UTE	0.85 B
Flux Codes	647 847 852 852 852

Photometric data file: D27976V8.ltd

We reserve the right to make technical changes without prior notice. 15.03.2011 © Zumtobel - 5 year guarantee when you register at www.zumtobel.com/guarantee/registration

DISEÑO ESQUEMATICO



Proyecto **BBVA Centro Operativo**
 Arquitecto **Skidmore, Owings & Merrill**

Fecha **10 de Dic de 2012**
 No. Proy. **512219.00**

Tipo **PA-1**

Philips Energy Advantage T5 25W Fluorescent Lamps featuring ALTO Lamp Technology

Ordering, Electrical and Technical Data (Subject to change without notice)

Product Number	Ordering Code	Watts	Bulb	Base	Pkg. Qty.	Color Temp (K)	CRI	Nom. Length (In.)	Rated Avg. Life (Hrs.) ¹	Approx. Initial Lumens ^{2,3}	Design Lumens ⁴
40630-6	F28T5/830/EA/ALTO 25W	25	T5	Min. Bipin	40	3000K	85	46	30,000	2900	2750
40631-4	F28T5/835/EA/ALTO 25W	25	T5	Min. Bipin	40	3500K	85	46	30,000	2900	2750
40632-2	F28T5/841/EA/ALTO 25W	25	T5	Min. Bipin	40	4100K	85	46	30,000	2900	2750

- 1) Average life under specified test conditions with lamps turned off and restarted no more frequently than once every 3 operating hours. Lamp life is appreciably longer if lamps are started less frequently.
- 2) Approximate initial lumens. The lamp lumen output is based upon lamp performance after 100 hours of operating life, when the output is measured during operation on a reference ballast under standard laboratory conditions.
- 3) For expected lamp lumen output, commercial ballast manufacturers can advise the appropriate ballast factor for each of their ballasts when they are informed of the designated lamp. The ballast factor is a multiplier applied to the designated lamp lumen output.
- 4) Design lumens are the approximate lamp lumen output at 40% of the lamp's rated average life. This output is based upon measurements obtained during lamp operation on a reference ballast under standard laboratory conditions.
- 5) Average life under engineering data with lamps turned off and restarted once every 12 operating hours.

Lumens vs. Ambient Temperature

Energy Advantage T5 25W Lamps

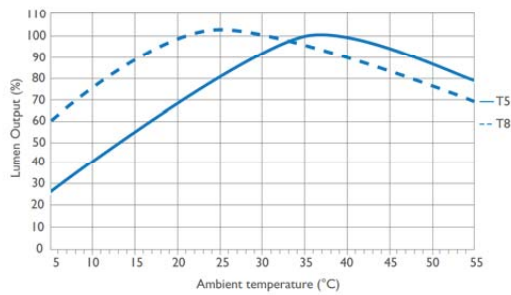

Energy Lumen Maintenance

Energy Advantage T5 25W Lamps

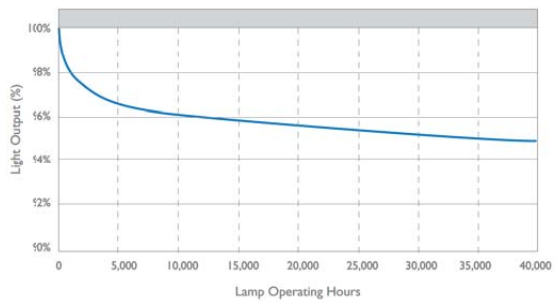

Rated Average Life

Energy Advantage T5 25W Lamps

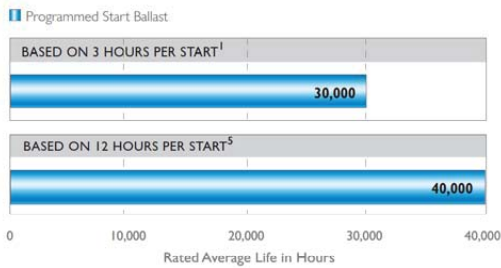

© 2010 Philips Lighting Company.
 A Division of Philips Electronics
 North America Corporation.
 All rights reserved.
 Printed in USA 9/10
 P-6030-A
 www.philips.com

Philips Lighting Company
 200 Franklin Square Drive
 Somerset, NJ 08873
 1-800-555-0050

Philips Lighting
 281 Hillmount Road
 Markham, Ontario
 Canada L6C 2S3
 1-800-555-0050
 A Division of Philips Electronics Ltd.



IOP2S2895SC@120	
Brand Name	OPTANIUM T5
Ballast Type	Electronic
Starting Method	Programmed Start
Lamp Connection	Series
Input Voltage	120-277
Input Frequency	50/60 HZ
Status	Active

Electrical Specifications

Lamp Type	Num. of Lamps	Rated Lamp Watts	Min. Start Temp (°F/C)	Input Current (Amps)	Input Power (ANSI Watts)	Ballast Factor	MAX THD %	Power Factor	MAX Lamp Current Crest Factor	B.E.F.
F14T5	2	14	0/-18	0.25	30	0.95	15	0.98	1.7	3.17
F21T5	1	21	0/-18	0.19	23	0.95	15	0.98	1.7	4.13
F21T5	2	21	0/-18	0.37	44	0.95	10	0.98	1.7	2.16
F28T5	1	28	0/-18	0.25	30	0.95	10	0.98	1.7	3.17
F28T5	2	28	0/-18	0.50	59	0.95	10	0.98	1.7	1.61
F28T5/ES (25W)	1	25	0/-18	0.22	27	0.95	10	0.98	1.7	3.52
* F28T5/ES (25W)	2	25	0/-18	0.45	54	0.95	10	0.98	1.7	1.76
F35T5	1	35	0/-18	0.31	37	0.95	10	0.98	1.7	2.57

Wiring Diagram

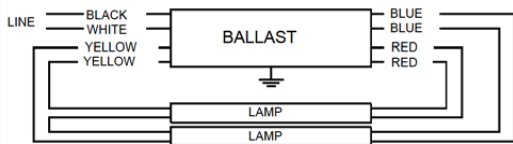

Diag . 74

The wiring diagram that appears above is for the lamp type denoted by the asterisk (*)

Standard Lead Length (inches)

	in.	cm.		in.	cm.
Black	22	55.9	Yellow/Blue		0
White	22	55.9	Blue/White		0
Blue	26	66	Brown		0
Red	26	66	Orange		0
Yellow	36	91.4	Orange/Black		0
Gray		0	Black/White		0
Violet		0	Red/White		0

Enclosure

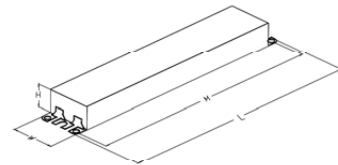

Enclosure Dimensions

OverAll (L)	Width (W)	Height (H)	Mounting (M)
9.50 "	1.7 "	1.18 "	8.90 "
9 1/2	1 7/10	1 9/50	8 9/10
24.1 cm	4.3 cm	3 cm	22.6 cm

Revised 01/12/2012



Data is based upon tests performed by Philips Lighting Electronics N.A. in a controlled environment and is representative of relative performance. Actual performance can vary depending on operating conditions. Specifications are subject to change without notice. All specifications are nominal unless otherwise noted.

PHILIPS LIGHTING ELECTRONICS N.A.

10275 WEST HIGGINS ROAD · ROSEMONT, IL 60018
 Tel: 800-322-2086 · Fax: 888-423-1882 · www.philips.com/advance
 Customer Support/Technical Service: 800-372-3331 · OEM Support: 866-915-5886

DISEÑO ESQUEMATICO



Proyecto **BBVA Centro Operativo**
 Arquitecto **Skidmore, Owings & Merrill**

Fecha **10 de Dic de 2012**
 No. Proy. **512219.00**

Tipo **PA-1**

C4X4L05DL

Calculite LED 4 1/2" X 4 1/2" Square Downlight

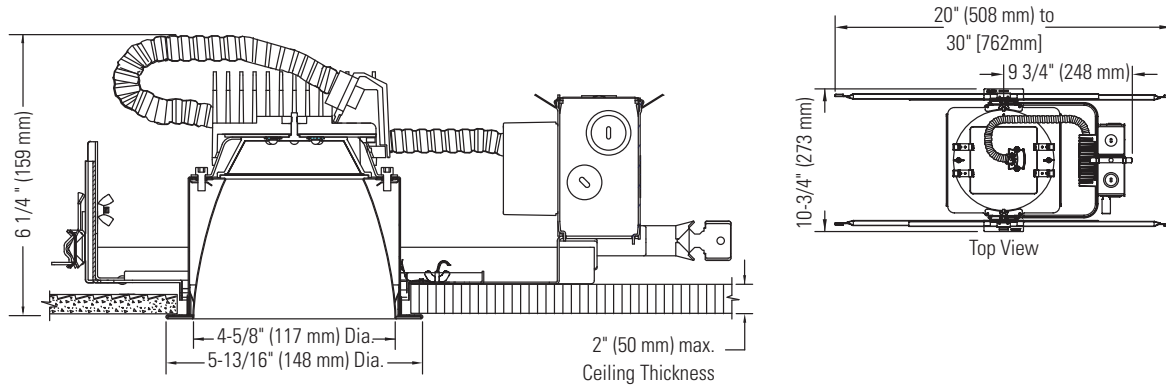

Ordering Guide: Light Engines

Light Engine Series	Style	Color Temperature	Reflector Finish	Flange	Options
C4X4L05	DL (Downlight)	27K (2700K) 30K (3000K) 35K (3500K) 40K (4000K)	CL (Clear) CCL (Comfort Clear) CCD (Comfort Clear Diffuse) CCZ (Champagne Bronze) WH (Painted White)	W (Painted white) P (Aperture-matching/polished)	EM (Integral emergency test switch)

Example: C4L05DL35KCCLWEM

Ordering Guide: Frame-in Kits

Frame-in Kit Series	Installation Options	Input Voltage	Options
C4X4L05	N (New construction)	1 (120V) 2 (277V)*	Blank (Electronic low voltage dimming) EM (Emergency) Z10V (0-10V dimming)
CUL05	J (J-box mount retrofit) S (Screw-in base retrofit (120V only))	1 (120V) 2 (277V)*	Blank (Electronic low voltage dimming) Z10V (0-10V dimming)

Example: C4L05N1EM

*277V dimming applications require Z10V option.

Job Information	Type:
Job Name:	
Cat. No.:	
Notes:	

PHILIPS
LIGHTOLIER

DISEÑO ESQUEMATICO



Proyecto **BBVA Centro Operativo**
Arquitecto **Skidmore, Owings & Merrill**

Fecha **10 de Dic de 2012**
No. Proy. **512219.00**

Tipo



C4X4L05DL

Calculite LED 4 1/2" X 4 1/2" Square Downlight

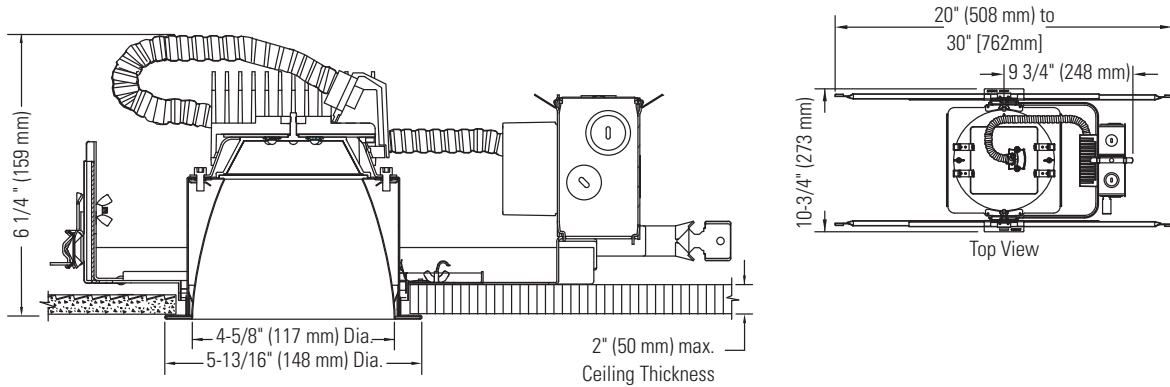

Features

Aperture: 4 5/8" x 4 5/8" (117mm) I.D., 5 13/16" (148mm) O.D.

Input Wattage: 9W (+/- 5%)

Reflector Cone: Aluminum. Provides 50° cutoff to source & source image. Self-flanged.

Depth (including Frame-in kit): 5 3/4" (146mm)

Power Connection: Attaches to frame-in kit via push-in connector (on frame). Removable cover provides access.

Technology

LED Board: Array of high brightness royal blue LED's.

Remote Phosphor Technology: Remote phosphor technology provides increased efficiency and color consistency. Phosphor lens assembly positioned in front of LED array converts blue light to white. Color shift will not exceed +/- 100K over life.

Optical Mixing Chamber: Lightolier-specific mixing chamber redirects back-reflected light through aperture resulting in 20% increase in efficiency.

Thermal Management: Proprietary heat sink and thermal design along with clean room assembly ensures specified performance.

Features (continued)

Rated Life: Based on IESNA LM-80-2008 50,000 hours at 70% lumen maintenance.

Photometric Performance: Tested in accordance to IESNA LM-79-2008

Options

Dimming Capability: See LED-DIM specification sheet

Emergency Capability (Integral): Add "EM" suffix. See LED-EM spec sheet.

Emergency Capability (Inverter): See LED-LMI specification sheet

Labels

UL (suitable for wet locations), cUL, I.B.E.W.
5 Year Warranty

Job Information Type:

PHILIPS
LIGHTOLIER

DISEÑO ESQUEMATICO

FMS

Proyecto **BBVA Centro Operativo**
Arquitecto **Skidmore, Owings & Merrill**

Fecha **10 de Dic de 2012**
No. Proy. **512219.00**

Tipo

PB

C4X4L05DL

Calculite LED 4 1/2" X 4 1/2" Square Downlight

10W LED, 3000K, CL FINISH TRIM

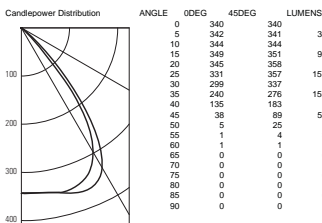

Trim: C4X410LEDDL30KCLV
Output lumens: 500 lm
Correlated Color Temp*: 3000K
Input Watts*: 8.7 w
Efficacy: 57.5 lm/w
CR†: 79
Spacing Criterion: 1.2

CEILING WALL	80%	70%	50%	30%	0%
RCR	70	50	30	10	0
Zonal Cavity Method - Effective Floor Cavity Reflectance = 20%	119	119	119	119	111
	113	110	108	105	108
	107	102	97	94	100
	90	81	74	69	80
	95	87	81	76	86
	84	75	68	63	74
	80	69	63	58	67
	75	65	58	54	64
	71	60	54	50	60
	67	56	50	46	56

ZONAL LUMENS AND PERCENTAGES

ZONE	LUMENS	% LUMINAIRE
0-30	289	57.7%
0-40	444	88.8%
0-60	500	99.9%
0-90	500	100.0%

Single Unit Data

Height to Lighted Plane	Initial Footcandles	Beam Diameter
5'	14	6"
6'	9	7"
7'	7	8"
8'	5	9"
9'	4	11"

Multiple Unit Data - RCR 2

Spacing	Initial	Watts/
On Ctr.	Footcandles	Sq. Ft.
5'	23	0.39
6'	15	0.25
7'	11	0.18
8'	9	0.15
9'	7	0.12

38x38x10' Room, Workplane 2 1/2' above floor, 80/50/20% Reflectances

CERTIFIED TEST REPORT NO. 15741*

10W LED, 3000K, CCD FINISH TRIM

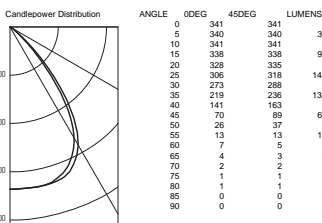

Trim: C4X410LEDDL30KCCDW
Output lumens: 491 lm
Correlated Color Temp*: 3000K
Input Watts*: 8.7 w
Efficacy: 56.4 lm/w
CR†: 79
Spacing Criterion: 1.1

CEILING WALL	80%	70%	50%	30%	0%
RCR	70	50	30	10	0
Zonal Cavity Method - Effective Floor Cavity Reflectance = 20%	119	119	119	116	111
	113	110	107	105	108
	106	101	96	93	99
	100	93	87	83	91
	94	86	79	75	84
	88	79	73	68	78
	83	73	67	62	72
	78	68	61	56	67
	74	63	57	52	61
	70	59	52	46	58
	66	55	49	44	55

ZONAL LUMENS AND PERCENTAGES

ZONE	LUMENS	% LUMINAIRE
0-30	270	55.1%
0-40	409	83.2%
0-60	486	98.9%
0-90	491	100.0%

Single Unit Data

Height to Lighted Plane	Initial Footcandles	Beam Diameter
5'	14	6"
6'	9	7"
7'	7	8"
8'	5	9"
9'	4	11"

Multiple Unit Data - RCR 2

Spacing	Initial	Watts/
On Ctr.	Footcandles	Sq. Ft.
5'	22	0.39
6'	14	0.25
7'	10	0.18
8'	9	0.15
9'	7	0.12

38x38x10' Room, Workplane 2 1/2' above floor, 80/50/20% Reflectances

CERTIFIED TEST REPORT NO. F09316*

10W LED, 3000K, WH FINISH TRIM

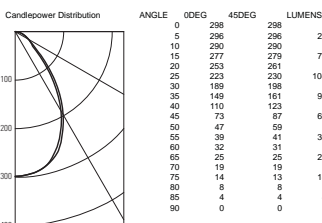

Trim: C4X410LEDDL30KWHW
Output lumens: 448 lm
Correlated Color Temp*: 3000K
Input Watts*: 8.7 w
Efficacy: 51.5 lm/w
CR†: 78
Spacing Criterion: 1.1

CEILING WALL	80%	70%	50%	30%	0%
RCR	70	50	30	10	0
Zonal Cavity Method - Effective Floor Cavity Reflectance = 20%	119	119	119	116	111
	111	107	104	101	105
	103	97	91	87	95
	96	88	81	76	86
	90	80	73	67	79
	84	73	66	60	72
	79	67	60	54	66
	74	62	55	50	61
	69	58	50	45	57
	65	54	47	42	53
	62	50	43	39	50

ZONAL LUMENS AND PERCENTAGES

ZONE	LUMENS	% LUMINAIRE
0-30	210	46.7%
0-40	306	68.3%
0-60	405	90.3%
0-90	448	100.0%

Single Unit Data

Height to Lighted Plane	Initial Footcandles	Beam Diameter
5'	12	5"
6'	8	6"
7'	6	7"
8'	5	8"
9'	4	9"

Multiple Unit Data - RCR 2

Spacing	Initial	Watts/
On Ctr.	Footcandles	Sq. Ft.
5'	19	0.39
6'	13	0.25
7'	9	0.18
8'	8	0.15
9'	6	0.12

38x38x10' Room, Workplane 2 1/2' above floor, 80/50/20% Reflectances

CERTIFIED TEST REPORT NO. F09317*

*Correlated Color Temperature within specs as defined in ANSI_NEMA_ANSLG C78.377-2008.
 †Specifications for the Chromaticity of Solid State Lighting Products.
 *Wattage controlled to within 55%.
 †Tested using absolute photometry as specified in LM79: IESNA
 Approved Method for the Electrical and Photometric Measurements of Solid-State Lighting Products.
 *Color Rendering Index within +/- 2%.

Job Information Type:



DISEÑO ESQUEMATICO



Proyecto **BBVA Centro Operativo**
 Arquitecto **Skidmore, Owings & Merrill**

Fecha **10 de Dic de 2012**
 No. Proy. **512219.00**

Tipo



Fisher Marantz Stone Partners in Architectural Lighting Design 22 West 19th Street New York, NY 10011

Type
Job Name
Catalog Number



Snap Strips & Industrials

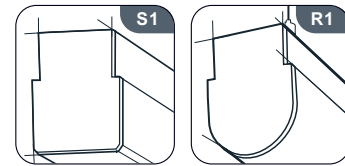
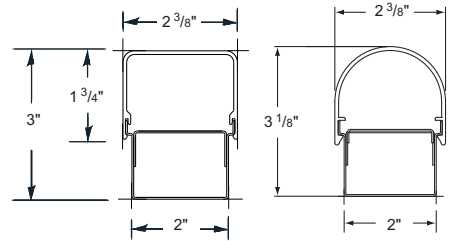
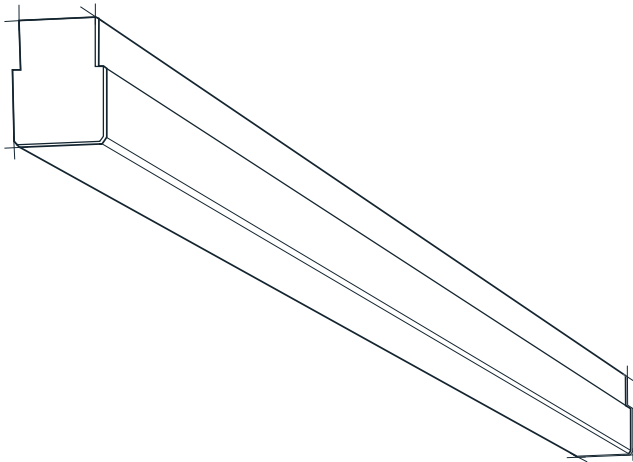

ordering

series	lamp rows	nominal length	shielding	color/finish	voltage	mounting	ceiling system*	options		
S1 square	1T8	02'	WA white acrylic	YGW* gloss white	120	SUR* surface or wall mount	X1 exposed T-bar	EML*		
R1 round	1T5	03'	SAL satin acrylic lens	TMW textured matte white	277	CA48" aircraft cable (adjustable)	X3 hard ceiling	EMH*		
	2T5	04'		YPE pewter	347				DM	
	1T5HO	06**		Y_ premium color	UNV*			CA96" aircraft cable (adjustable)	X6 slot grid	RSE**
		08**		LPA* linear prismatic acrylic stack optic lens	*120-277				*specify with cable mount only	10THD**
	R_**		*R1 only	CC custom color		*standard		B_		
			*fixtures have two lenses **row length	GLV** galvanized				FH		
								TRS		
								OCO*		
								OC2C††		
								OCDM*		
								T5OPT††		
								EBCP1G		
								EBCP2G		

Features Low-profile wrap strip light with extruded white acrylic lens that holds securely with no hardware or fasteners. Dimming, emergency, and integrated occupancy sensor options are available – see S-Occ™ information for restrictions and planning information.

Construction Housing construction is die-formed 22-gauge steel with spring-fastened aluminum endplates. Six and eight foot fixtures have two diffusers with an intermediate plate at the midpoint of the housing. Lengths for T5/T5HO fixtures can be specified in T5/T5HO optimized lengths (**T5OPT**) to minimize socket shadows. See Mounting Locations for **T5OPT** fixture lengths.

Finish The standard exterior body color is polyester powder paint in gloss white. See ordering matrix for optional finishes. End plates are painted black (YBB) with optional galvanized (GLV) finish unless otherwise specified.

Electrical T8 fixtures have instant-start ballasts with <20% THD. Fixtures are U.L. Damp listed and I.B.E.W. manufactured. Maximum ballast size is 1.7" width by 1.18" height.

Mounting Fixture is wall- or surface-mounted, or suspended with cables.

Options **EML:** emergency battery (600-700 lumens); **EMH:** emergency battery (1100-1400 lumens); **DM:** dimming (specify manufacturer, voltage and other requirements); **RSE:** rapid-start electronic; **10THD:** ballast with <10% total harmonic distortion; **B_:** specific ballast, specify manufacturer and catalog number (consult factory); **FH:** fixture fusing (slow blow); **TRS:** tamper resistant fasteners; **OCO:** S-Occ™ Integrated Occupancy System – all lamps on/off; **OC2C:** S-Occ™ - one lamp sensed, one lamp on constantly; **OCDM:** S-Occ™ - dim to standby mode; **T5OPT:** T5/T5HO optimized fixture lengths; **EBCP:** electrical box cover plate/mud ring, single gang or 2 gang.

*minimum fixture length is 4'
**T8 only
†‡T5 only-not available with EML or EMH
†† T5/HO optimized lengths

Prudential reserves the right to change design specifications or materials without notice.

0815 Prudential Ltg. 1737 East 22nd Street, Los Angeles, CA 90058 12/11

DISEÑO ESQUEMATICO



Proyecto **BBVA Centro Operativo**
Arquitecto **Skidmore, Owings & Merrill**

Fecha **10 de Dic de 2012**
No. Proy. **512219.00**

Tipo





Strips & Industrials **Snap**

photometric data

S1-1T5-04-SAL-YGW

Report # LL1000-0301 D=72.7% I=23.3%
Spacing Criteria: Along 1.6; Across 1.54
Lamp Lumens: 2900 Input Watts: 31.90

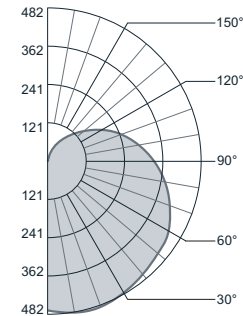

Candlepower Summary

Vertical Angle	Horizontal Angle			
	0°	22.5°	45°	67.5° 90°
0	466	466	466	466
5	463	465	469	473
15	437	447	463	476
25	388	410	441	467
35	323	359	409	451
45	252	302	373	435
55	204	244	339	419
65	106	164	301	393
75	51	107	246	355
85	150	90	175	304
90	137	81	160	280
95	127	75	148	253
105	104	64	142	205
115	84	53	114	160
125	33	43	89	122
135	17	40	68	93
145	9	22	52	68
155	10	15	35	46
165	11	13	18	25
175	11	11	12	12
180	0	0	0	0

Zonal Lumen Summary

Zone	% Lamp	% Luminaire
0-90	67.6	75.7
90-180	21.7	24.3

Efficiency = 89.4%

Luminance Summary (cd/m²)

Angle	0°	45°	90°
45	4640	4783	5300
55	4569	4703	5506
65	3330	4705	5740
75	2362	4561	5943
85	16869	4142	6203

Coefficients of Utilization (%)

	Floor effective floor cavity reflectance = 20			
	80	70	50	50
Ceiling	80	70	50	50
Wall	70	50	30	10
RCR	0	10	11	10
1	96	96	96	87
2	87	81	75	70
3	82	77	72	67
4	77	72	67	65
5	72	67	62	61
6	68	60	54	51
7	65	57	51	52
8	62	55	47	41
9	59	50	43	37
10	54	42	34	28
11	48	40	34	26
12	42	35	28	21
13	38	31	25	19
14	34	28	22	16
15	31	25	20	14
16	28	22	18	12
17	25	19	16	10
18	23	17	14	9
19	21	14	12	8
20	19	12	10	7

R1-1T5-04-LPA-TMW-120

Report # LL1000-0601 D=86.5% I=13.5%
Spacing Criteria: Along 1.2; Across 1.6
Lamp Lumens: 2900 Input Watts: 31.6

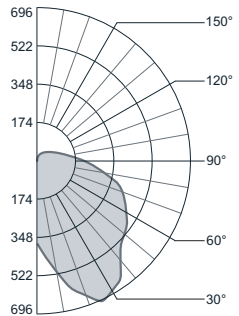

Candlepower Summary

Vertical Angle	Horizontal Angle			
	0°	22.5°	45°	67.5° 90°
0	371	371	371	371
5	367	379	406	431
15	353	422	524	584
25	330	470	604	674
35	307	499	641	669
45	288	498	565	522
55	261	416	406	469
65	162	218	314	409
75	34	114	185	343
85	95	65	131	226
90	78	54	105	182
95	55	52	90	148
105	17	40	74	106
115	15	34	58	88
125	9	18	51	68
135	9	16	41	52
145	9	14	31	38
155	9	13	22	30
165	9	11	15	20
175	10	10	11	11
180	0	0	0	0

Zonal Lumen Summary

Zone	% Lamp	% Luminaire
0-90	77.7	86.5
90-180	12.1	13.5

Efficiency = 89.8%

Luminance Summary (cd/m²)

Angle	0°	45°	90°
45	5568	7314	6152
55	6132	5629	5986
65	5045	4844	5736
75	1644	3330	5540
85	11016	2938	4618

Coefficients of Utilization (%)

	Floor effective floor cavity reflectance = 20			
	80	70	50	50
Ceiling	80	70	50	50
Wall	70	50	30	10
RCR	0	10	10	10
1	104	104	104	93
2	91	85	79	75
3	87	81	77	72
4	81	77	72	68
5	77	72	67	65
6	72	67	62	61
7	69	62	56	57
8	65	59	51	44
9	61	52	45	37
10	56	44	37	30
11	51	43	36	28
12	47	37	31	24
13	44	34	28	21
14	41	32	26	19
15	38	29	24	17
16	35	27	22	15
17	33	25	20	13
18	31	23	18	11
19	29	21	16	10
20	27	19	14	9

installation

Adjoining Detail

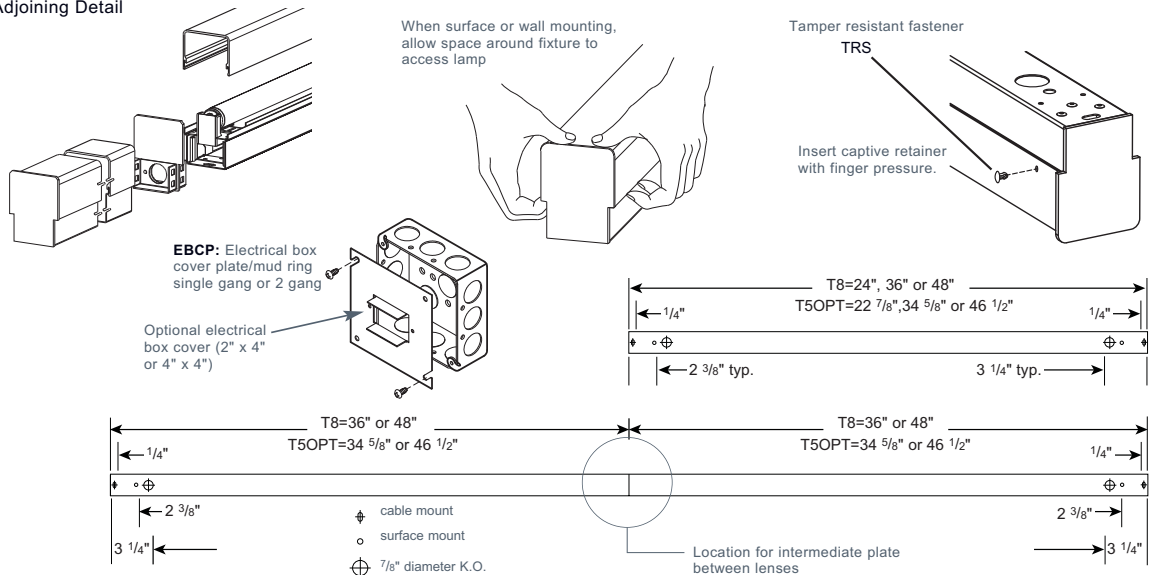

Prudential Ltg. tel 213.746.0360 fax 213.741.8590 prulite.com **0815**

DISEÑO ESQUEMATICO



Proyecto **BBVA Centro Operativo**
Arquitecto **Skidmore, Owings & Merrill**

Fecha **10 de Dic de 2012**
No. Proy. **512219.00**

Tipo



Philips Energy Advantage T5 25W Fluorescent Lamps featuring ALTO Lamp Technology

Ordering, Electrical and Technical Data (Subject to change without notice)

Product Number	Ordering Code	Watts	Bulb	Base	Pkg. Qty.	Color Temp (K)	CRI	Nom. Length (In.)	Rated Avg. Life (Hrs.) ¹	Approx. Initial Lumens ^{2,3}	Design Lumens ⁴
40630-6	F28T5/830/EA/ALTO 25W	25	T5	Min. Bipin	40	3000K	85	46	30,000	2900	2750
40631-4	F28T5/835/EA/ALTO 25W	25	T5	Min. Bipin	40	3500K	85	46	30,000	2900	2750
40632-2	F28T5/841/EA/ALTO 25W	25	T5	Min. Bipin	40	4100K	85	46	30,000	2900	2750

- 1) Average life under specified test conditions with lamps turned off and restarted no more frequently than once every 3 operating hours. Lamp life is appreciably longer if lamps are started less frequently.
- 2) Approximate initial lumens. The lamp lumen output is based upon lamp performance after 100 hours of operating life, when the output is measured during operation on a reference ballast under standard laboratory conditions.
- 3) For expected lamp lumen output, commercial ballast manufacturers can advise the appropriate ballast factor for each of their ballasts when they are informed of the designated lamp. The ballast factor is a multiplier applied to the designated lamp lumen output.
- 4) Design lumens are the approximate lamp lumen output at 40% of the lamp's rated average life. This output is based upon measurements obtained during lamp operation on a reference ballast under standard laboratory conditions.
- 5) Average life under engineering data with lamps turned off and restarted once every 12 operating hours.

Lumens vs. Ambient Temperature

Energy Advantage T5 25W Lamps

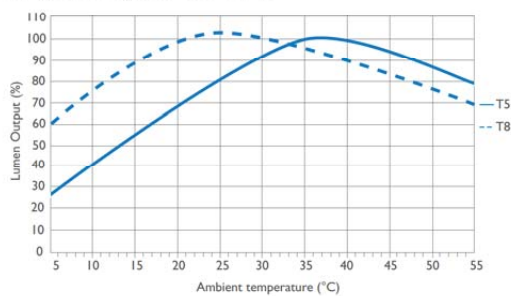

Energy Lumen Maintenance

Energy Advantage T5 25W Lamps

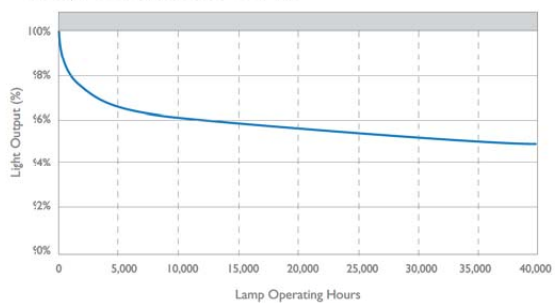

Rated Average Life

Energy Advantage T5 25W Lamps

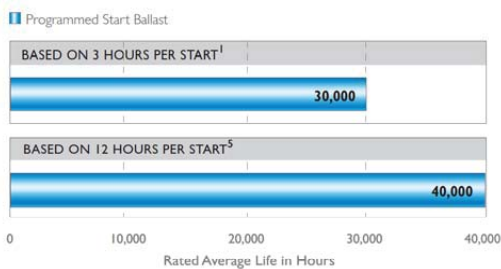

© 2010 Philips Lighting Company.
 A Division of Philips Electronics
 North America Corporation.
 All rights reserved.
 Printed in USA 9/10
 P-6030-A
 www.philips.com

Philips Lighting Company
 200 Franklin Square Drive
 Somerset, NJ 08873
 1-800-555-0050

Philips Lighting
 281 Hillmount Road
 Markham, Ontario
 Canada L6C 2S3
 1-800-555-0050
 A Division of Philips Electronics Ltd.

DISEÑO ESQUEMATICO



Proyecto **BBVA Centro Operativo**
 Arquitecto **Skidmore, Owings & Merrill**

Fecha **10 de Dic de 2012**
 No. Proy. **512219.00**

Tipo





IOP2S2895SC@120	
Brand Name	OPTANIUM T5
Ballast Type	Electronic
Starting Method	Programmed Start
Lamp Connection	Series
Input Voltage	120-277
Input Frequency	50/60 HZ
Status	Active

Electrical Specifications

Lamp Type	Num. of Lamps	Rated Lamp Watts	Min. Start Temp (°F/C)	Input Current (Amps)	Input Power (ANSI Watts)	Ballast Factor	MAX THD %	Power Factor	MAX Lamp Current Crest Factor	B.E.F.
F14T5	2	14	0/-18	0.25	30	0.95	15	0.98	1.7	3.17
F21T5	1	21	0/-18	0.19	23	0.95	15	0.98	1.7	4.13
F21T5	2	21	0/-18	0.37	44	0.95	10	0.98	1.7	2.16
F28T5	1	28	0/-18	0.25	30	0.95	10	0.98	1.7	3.17
F28T5	2	28	0/-18	0.50	59	0.95	10	0.98	1.7	1.61
F28T5/ES (25W)	1	25	0/-18	0.22	27	0.95	10	0.98	1.7	3.52
* F28T5/ES (25W)	2	25	0/-18	0.45	54	0.95	10	0.98	1.7	1.76
F35T5	1	35	0/-18	0.31	37	0.95	10	0.98	1.7	2.57

Wiring Diagram

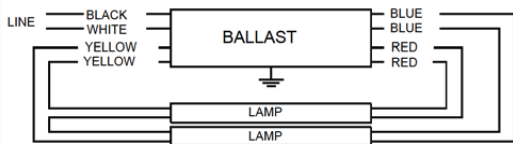

Diag . 74

The wiring diagram that appears above is for the lamp type denoted by the asterisk (*)

Standard Lead Length (inches)

	in.	cm.		in.	cm.
Black	22	55.9	Yellow/Blue		0
White	22	55.9	Blue/White		0
Blue	26	66	Brown		0
Red	26	66	Orange		0
Yellow	36	91.4	Orange/Black		0
Gray		0	Black/White		0
Violet		0	Red/White		0

Enclosure

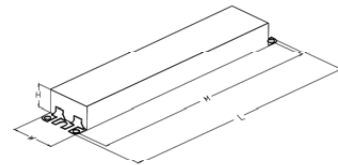

Enclosure Dimensions

OverAll (L)	Width (W)	Height (H)	Mounting (M)
9.50 "	1.7 "	1.18 "	8.90 "
9 1/2	1 7/10	1 9/50	8 9/10
24.1 cm	4.3 cm	3 cm	22.6 cm

Revised 01/12/2012



Data is based upon tests performed by Philips Lighting Electronics N.A. in a controlled environment and is representative of relative performance. Actual performance can vary depending on operating conditions. Specifications are subject to change without notice. All specifications are nominal unless otherwise noted.

PHILIPS LIGHTING ELECTRONICS N.A.

10275 WEST HIGGINS ROAD · ROSEMONT, IL 60018
 Tel: 800-322-2086 · Fax: 888-423-1882 · www.philips.com/advance
 Customer Support/Technical Service: 800-372-3331 · OEM Support: 866-915-5886

DISEÑO ESQUEMATICO



Proyecto **BBVA Centro Operativo**
 Arquitecto **Skidmore, Owings & Merrill**

Fecha **10 de Dic de 2012**
 No. Proy. **512219.00**

Tipo

